



Index

Taps, Burs & Blades

A

Annular Cutters

Carbide Tipped

CT150 & CT200 PT-13, PT-15

IBS High Speed Steel PT-15

Assortments, Cutting Tools

Advanced Edge Power Reciprocating Saw Blades

with Tool Ease Lubricant Stick PT-42

Annular Cutters - Carbide Tipped

PT-14

Annular Cutters - High Speed Steel PT-16

Black Hole Carbide Tipped Cutters

1" Depth - 4 Pc.Set PT-21

1" Depth - 5 Pcs PT-21

3/16" Depth - 5 Pc. PT-21

762R - 5 Pc. - 3/16" Depth PT-20

763R - 4 Pc. 1" Depth PT-20

764R - 5 Pc. - 1" Depth PT-21

Carbide Burs PT-54, PT-56

Hole Saws

Bi-Metal

Advanced Bi-Metal Hole Saws 2-1/8"- 4" PT-25

Advanced Bi-Metal Hole Saws 3/4"- 4" PT-25

Advanced Bi-Metal Hole Saws 5/8"- 2" PT-26

M42 Thin Wall Hole Saws Travel Tray Assortment PT-17

Hole Saws - Bi-Metal

Advanced Edge Bi-Metal Hole Saws 2-1/8" - 4" PT-25, PT-26

Advanced Edge Bi-Metal Hole Saws 3/4" - 4" PT-25, PT-26

Advanced Edge Bi-Metal Hole Saws 5/8" - 2" PT-25, PT-26

Advanced Edge Bi-Metal Hole Saws 13 Pc Kit PT-27

Advanced Edge Bi-Metal Hole Saws 15 Pc Kit PT-27

Nitro-Carb Power Tap & Hex Die Sets PT-8, PT-10

Saw Blades

Advanced Edge Power Reciprocating Saw Blades with Tool Ease Lubricant Stick PT-42

Bi-Metal Air Saw Blades PT-47

Bi-Metal Reciprocating Saw Blades PT-46

Bore Blades and Demolition Blades PT-46

IBS Hi-Alloy & Triple-Cut Hacksaw Blades PT-41

Reciprocating Saw Handle & Blade Kit PT-45

Special Purpose Reciprocating Saw Blades PT-46

Taps, Metric

Index

18 Metric Taps & Drill Bits w/Index PT-7

Organizer

29 pc Metric Taps, Drill Bits, Hex Dies & Tools PT-7

Taps, Standard

Drawer

4-40 thru 1/2-10 Tap, Die & Drill Set PT-9

9/16-12 thru 3/4-16 Tap, Die & Drill Set PT-9

Index

10 Pc NC/NF Power Taps w/Index PT-5, PT-8

10 Pc NC/NF Taper Taps w/Inde PT-8

18 Pc NC Bottom Taps & Drill Bits w/Index PT-8

18 Pc NC Taper Taps & Drill Bits w/Index PT-8

Nitro-Carb Hand Tap PT-8

B

Blades

100 PK Shark Serrated Blades PT-49

Bandsaw, Bi-Metal

Anatomy of a Bandsaw Blade PT-34

General Information PT-33

Portable Blades PT-38

Tooth Selection Guide PT-35

Troubleshooting PT-36, PT-37

Bi-Metal

Air Saw Blades PT-47

Reciprocating Saw PT-43

Boar Blades PT-44

Thick Demolition PT-44

Sabre/Jig PT-47

Chop Saw-Carbide Tipped

14" Blade for Aluminum PT-31

14" Blade for Stainless Steel PT-31

14" Blade for Steel PT-31

Circular Saw

Combination Blade PT-29

Heavy Duty Deck / Nail Cutting Blade PT-29

Miter Saw Blade PT-30

Miter Saw Rip Blade PT-30

Novelty Combo Blade PT-29

Steel & Iron Cutting Blade PT-29

Circular Saw-Carbide Tipped

7-1/4" Blades for Aluminum PT-31

7-1/4" Blades for Steel PT-31

SteelMax 7-1/4" Blades for Stainless Steel PT-31

Hacksaw

IBS Hi-Alloy PT-40

Reciprocating Saw

Advanced Edge Power Reciprocating Saw Blades PT-42

Bi-Metal PT-43

Double Edge Bi-Metal Bore Blades PT-44, PT-45

Power Curve PT-44

Tungsten Carbide PT-44

Retractable Knife

HD 8 PT Snap Blade PT-48

Heavy Duty Hook Utility Blades PT-48

"Rapid Razor" Dispenser PT-48

Single Edge Razor Blades PT-49

Burs - Carbide, Rotary

14° Taper Radius PT-53

Ball Shape PT-53

Cone Shape PT-53



T
A
P
S
B
U
R
S
B
L
A
D
E
S

Cylinder PT-52
Cylinder End Cut PT-52
Cylinder Radius End PT-52
General Information
 Surface Feet Conversion Chart PT-55
Oval PT-53
Tree Pointed End PT-53
Tree Radius End PT-53

F

Files

Accessories
 File Card PT-58
 Skroo-Zon File Handles PT-59
Assortments
 Black Maxi-Sharp Files PT-59
Black Maxi-Sharp
 3 Square Files PT-58
 All Purpose PT-57
 Flat Files PT-57
 Half-Round PT-57
 Mill PT-57
 Multi-Kut Flat PT-58
 Round PT-58
 Tapered Saw PT-58

Chainsaw Files PT-58

Tungsten Points File with Pocket Clip PT-58

Fiskars Utility Knives & Tools

Tools

Fiskars® PowerGear Plastic Pipe Cutter PT-51
 Fiskars PowerArc Easy Action Shears (10") PT-51
 Fiskars PowerArc Utility Snips (8") PT-51

Utility Knives

Fiskars Pro Fixed Blade Utility Knife PT-50
 Fiskars Pro Folding Utility Knife PT-50
 Fiskars Pro Retractable Blade Utility Knife PT-50

H

Hacksaw Frame, 4-in-1 PT-39

Hex Dies

Nitro-Carb PT-12
 Coarse Thread PT-12
 Fine Thread PT-12
 Metric Thread PT-12
 Pipe Thread PT-12

Hole Saws

Bi-Metal

Advanced Bi-Metal Hole Saws PT-24
 Arbors PT-24
 Hole Saw Arbor Replacement Drill PT-24

Carbide Tipped Annular Cutters

CT150 PT-13, PT-15, PT-16
 CT150 Accessories PT-13, PT-15
 CT200 PT-13, PT-15, PT-16

Carbide Tipped, Black Hole

3/16" Depth

Accessories PT-18

Carbide Tipped Hole Cutters PT-19

M42 Thin Wall Hole Saws PT-17

Pilot Drill Bits PT-23

Rapid Core™ Ejecting Hole Saw Arbors PT-23

Technical Information

Cutting Speeds PT-28

I

Information

"Power" Taps PT-4

K

Knives

Cartridge Loading Snap Knife with Rubber Grip PT-48

Fiskars Utility Knives

Fiskars Pro Fixed Utility Knife PT-50

Fiskars Pro Retractable Blade Utility Knife PT-50

HD Retractable Blade 8 Pt. Breakaway Knife PT-48

"Rapid Razor" Utility Knife PT-48

Revo Folding Knife PT-49

SHARK Combination Utility Knife PT-49

Utility Knife Holster PT-48

L

Lubricants

Sluggo Cutting Fluid for Mag Drills PT-22

Ultra Lube Super Premium Cutting Fluid PT-23

T

Taps

Nitro-Carb

Bottom PT-6

General Information PT-6

Hand Tap Assortments - Index PT-8

HSS Taper Pipe Taps PT-6, PT-8, PT-10

Metric Taps PT-7

Metric Tap Sets PT-7

NPT Pipe PT-7

Plug PT-6

Power PT-6

Power Tap & Hex Die Sets PT-8, PT-10

Pro Power Taps PT-5

Taper PT-6

Threaded Rod

Tools

Deburring Tools (T03) PT-56

Tools

Hand

4-in-1 Hacksaw Frame PT-39

Cartridge Loading Snap Knife with Rubber Grip PT-48, PT-49

HD Retractable Blade

8 Pt. Breakaway Knife PT-48



Index

Heavy Duty Metal Scraper PT-49
Professional Hex Die Wrench PT-11
Professional Straight Handle Tap Wrench PT-11
Reciprocating Saw Handle PT-45
Revo Folding Knife PT-49
Tapping Tool & Guide PT-11
T-Handle Ratcheting Tap Wrenches PT-11
T-Handle Tap Wrench PT-11

Power

7-1/4 Circular Saw PT-31
14" Circular Saw PT-32
Compact Magnetic Drill Press PT-22
Magnetic Drill Press PT-22
Slugger Cutting Fluid for Mag Drills PT-22
Variable Speed / Reversible
Magnetic Drill Press PT-22

Replacement Parts

HD 8 PT Snap Blade PT-48
Heavy Duty Hook Utility Blades PT-48
Plastic Razor Blades PT-49
Single Edge Razor Blades PT-49

Threaded Rod

Deburring Tool 3Pc Set (T03) PT-56

T
A
P
S

B
U
R
S

B
L
A
D
E
S



IBS, INCORPORATED

Nitro Carb Taps P10

"Power" Taps Changing The Way Holes Are Tapped



Before the "Power" Tap, it was said that all taps broke before they wore out. But now that has all changed. Called a "Power" Tap because of the way it "shoots" the chips out ahead of the tap. The design is radically different from that of the ordinary tap and therefore can be used well in power tools. This change is most noticeable when tapping stringy materials, where before the flutes would become loaded and cause the tap to break. The "Power" Tap design makes it possible to use shallower flutes which translates to a stronger tap. This all adds up to a tap which requires less power to drive and, for some classes of work (through holes and blind holes with sufficient clearance at the bottom, most notably), are much more economical to use than ordinary hand taps.

T
A
P
S

B
U
R
S

B
L
A
D
E
S

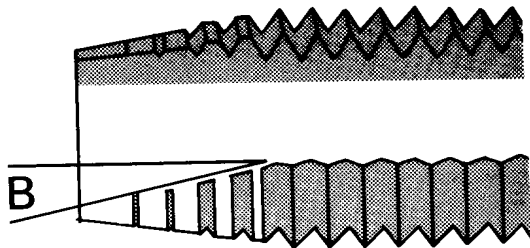
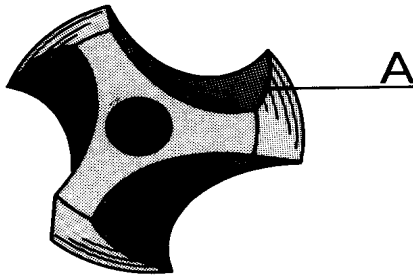

"Power" Tap Design

The cutting edges (**A**) at the point of the tap are ground at an angle (**B**) to the axis for a distance of four or five threads. This angle, in conjunction with the hook on the cutting edge of the land and the special flute form, produces the long curling chips. These chips, instead of passing out or backing in the flutes, are "shot" out ahead of the tap.

"Power" Tap



Hand Tap



Stronger

A "Power" Tap does not need the deep flutes that an ordinary tap requires for the elimination of chips. Thus fewer and shallower flutes can be used giving the tap a larger cross sectional arc and extra strength.

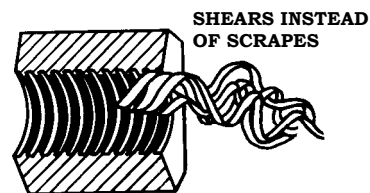

Less Power Needed

The metal is sheared by the angular cutting edge with a hook on the land instead of being torn or pulled off with a scraping action. Much less power is needed for this shearing across than is required for hand taps.

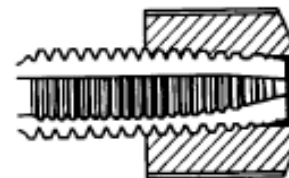

Accuracy

The first few teeth of the "Power" Tap do all the cutting. The remainder of the threaded section serves as a lead screw, steadying the tap and insuring a more accurately tapped hole.

Nitro-Carb Taps P10

Pro Power Taps

IBS Pro Power Taps are designed for difficult materials including: stainless steel, alloy steels, and high carbon steel. Special tool geometry creates less torque, better removal of chips and runs cooler. Reduced neck design enhances the flow of cutting fluid to cutting teeth and reduces surface contact between the tool and work piece for more efficient threading.

- **Constructed of Chromium, Vanadium, Molybdenum and Cobalt Alloys**
- **Cuts Harder Materials than standard HSS Tap - Cuts Up to 45 Rockwell "C"**
- **Superior Design Actually Shoots Chips Out Ahead of the Tap Providing a Faster, Cleaner and Smoother Thread and a Longer Lasting Tap.**

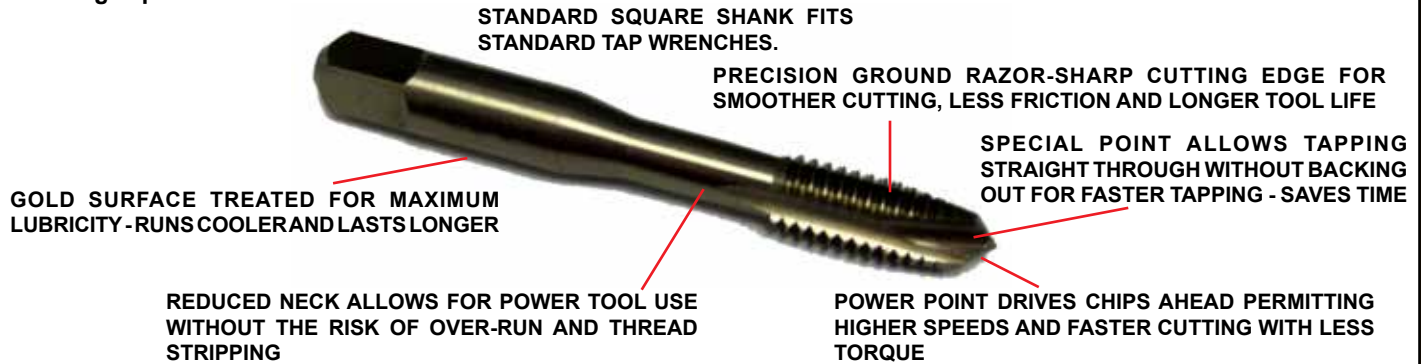

Inch

| Thread Size | # of Flutes | IBS No. | Thread Size | # of Flutes | IBS No. | Thread Size | # of Flutes | IBS No. | Thread Size | # of Flutes | IBS No. |
|-------------|-------------|---------|-------------|-------------|---------|-------------|-------------|---------|-------------|-------------|---------|
| 4-40 | 2 | 18000 | 10-32 | 3 | 18004 | 5/16-18 | 2 | 18008 | 7/16-14 | 3 | 18012 |
| 6-32 | 2 | 18001 | 12-24 | 3 | 18005 | 5/16-24 | 2 | 18009 | 7/16-20 | 3 | 18013 |
| 8-32 | 3 | 18002 | 1/4-20 | 3 | 18006 | 3/8-16 | 3 | 18010 | 1/2-13 | 3 | 18014 |
| 10-24 | 3 | 18003 | 1/4-28 | 3 | 18007 | 3/8-24 | 3 | 18011 | 1/2-20 | 3 | 18015 |

Metric

| Thread Size | # of Flutes | IBS No. | Thread Size | # of Flutes | IBS No. | Thread Size | # of Flutes | IBS No. | Thread Size | # of Flutes | IBS No. |
|-------------|-------------|---------|-------------|-------------|---------|-------------|-------------|---------|-------------|-------------|---------|
| M3-.5 | 2 | 18020 | M6-1.0 | 3 | 18023 | M10-1.5 | 3 | 18025 | M14-2.0 | 3 | 18027 |
| M4-.7 | 3 | 18021 | M8-1.25 | 3 | 18024 | M12-1.75 | 3 | 18026 | M16-2.0 | 3 | 18028 |
| M5-.8 | 3 | 18022 | | | | | | | | | |

Pro Power Tap Assortments (P15)



| IBS No. | Description |
|---------|---|
| 563P | 10 Pc NC/NF Pro Power Taps with Index Tap Sizes: 1/4-20, 1/4-28, 5/16-18, 5/16-24, 3/8-16, 3/8-24, 7/16-14, 7/16-20, 1/2-13, 1/2-20 Packaged in a sturdy 10 pc. metal index |
| 17456 | 18 Pc NC Pro Power Taps & Drill Bits with Index Tap Sizes: 6-32, 8-32, 10-24, 10-32, 1/4-20, 5/16-18, 3/8-16, 7/16-14, 1/2-13 Drill Bits: #36, #29, #25, #21, #7, "F", 5/16, "U", 27/64 Packaged in a sturdy 18 pc. metal index |
| 17458 | 8 Pc Metric Pro Power Taps with Index Tap Sizes: M3-0.50, M4-0.70, M5-0.80, M6-1.00, M8-1.25, M10-1.50, M12-1.75, M16-2.00 Packaged in a sturdy 10 pc. metal index |
| 17457 | 28 Pc NC/NF Pro Power Taps & Drill Bits with Organizer Tap Sizes: 6-32, 8-32, 10-24, 10-32, 1/4-20, 1/4-28, 5/16-18, 5/16-24, 3/8-16, 3/8-24, 7/16-14, 7/16-20, 1/2-13, 1/2-20 Drill Bits: #36, #29, #25, #21, #7, #3 "F", I, Q, 5/16, 3/8, 25/64, 27/64, 29/64 Packaged in a sturdy 3 drawer organizer |

TAPS BURSES BLADES



IBS, INCORPORATED

Nitro-Carb Taps P10

Nitro-Carb Taps

IBS Nitro-Carb Taps are professional quality cutting tools for maintenance and repair applications. They are made of the same quality alloys as our drill bits (Chromium, Vanadium, and Molybdenum), which allows for faster cutting and longer tap life.

FEATURES:

- **Nitro-Carburized finish** at 950°F to be measurably harder than high speed steel.
- **Space age Nitro-Carb steel** withstands substantially higher operating temperatures while maintaining sharpness.
- **Requires 30% less torque** to provide faster cutting.
- **30% heavier web** than regular taps — for less tap breakage.
- **Special Hi-Tungsten & High Molybdenum tool steels**, gold surface treated for maximum lubricity.
- **Precision ground threads** for the ultimate in accuracy and performance.
- **3 styles** - Taper, Power & Bottoming styles provide versatility in tough materials both blind & through holes.
- **For general use in production tapping** or hand operations.
- **Cuts materials up to 55 Rockwell** on the "C" scale.
- **Thread tolerances are to .0005.** Gives perfect threads every time.
- **Outlasts ordinary taps 3 to 1.**
- **Recommended for stainless** and other hard metals.
- **Nitro-Carb Taps will reduce your "Tapped Hole" costs** tremendously saving time, labor, & money
- **Triple Heat Treated Ground Threads** and Special Alloys all combine to give you a 200% higher breaking torque over ordinary taps.



POWER

Three to five threads chamfered. For general use when tapping into the bottom of a hole is not critical.



TAPER

Eight to ten threads chamfered for easy use thread starting in tough materials



BOTTOM

One and one half threads chamfered. Use after threads have been started for tapping to the bottom of a hole.

| Thread Size | Drill Size | Power | # of Flutes | Plug | # of Flutes | Taper | # of Flutes | Bottom | # of Flutes | Thread Size | Drill Size | Power | # of Flutes | Plug | # of Flutes | Taper | # of Flutes | Bottom | # of Flutes |
|-------------|------------|-------|-------------|------|-------------|-------|-------------|--------|-------------|-------------|------------|-------|-------------|-------|-------------|-------|-------------|--------|-------------|
| 4-40 | 43 | 17629 | 2 | | | 17600 | 3 | 17655 | 3 | 7/16-20 | 25/64 | 17642 | 3 | | | 17613 | 4 | 17668 | 4 |
| 6-32 | 36 | 17630 | 2 | | | 17601 | 3 | 17656 | 3 | 1/2-13 | 27/64 | 17643 | 3 | | | 17614 | 4 | 17669 | 4 |
| 8-32 | 29 | 17631 | 2 | | | 17602 | 4 | 17657 | 4 | 1/2-20 | 29/64 | 17644 | 3 | | | 17617 | 4 | 17670 | 4 |
| 10-24 | 25 | 17632 | 2 | | | 17603 | 4 | 17658 | 4 | 9/16-12 | 31/64 | | | 17645 | 4 | 17619 | 4 | 17671 | 4 |
| 10-32 | 21 | 17633 | 2 | | | 17604 | 4 | 17659 | 4 | 9/16-18 | 1/2 | | | 17646 | 4 | 17620 | 4 | 17672 | 4 |
| 12-24 | 16 | 17634 | 2 | | | 17605 | 4 | 17660 | 4 | 5/8-11 | 17/32 | 17647 | 3 | | | 17621 | 4 | 17673 | 4 |
| 1/4-20 | 7 | 17635 | 2 | | | 17606 | 4 | 17661 | 4 | 5/8-18 | 9/16 | 17648 | 3 | | | 17622 | 4 | 17674 | 4 |
| 1/4-28 | 3 | 17636 | 2 | | | 17607 | 4 | 17662 | 4 | 3/4-10 | 21/32 | 17649 | 3 | | | 17623 | 4 | 17675 | 4 |
| 5/16-18 | "F" | 17637 | 2 | | | 17608 | 4 | 17663 | 4 | 3/4-16 | 11/16 | 17650 | 3 | | | 17624 | 4 | 17676 | 4 |
| 5/16-24 | "I" | 17638 | 2 | | | 17609 | 4 | 17664 | 4 | 7/8-9 | 49/64 | | | 17651 | 4 | 17625 | 4 | 17677 | 4 |
| 3/8-16 | "O" | 17639 | 3 | | | 17610 | 4 | 17665 | 4 | 7/8-14 | 13/16 | | | 17652 | 4 | 17626 | 4 | 17678 | 4 |
| 3/8-24 | "Q" | 17640 | 3 | | | 17611 | 4 | 17666 | 4 | 1-8 | 7/8 | | | 17653 | 4 | 17627 | 4 | 17679 | 4 |
| 7/16-14 | "U" | 17641 | 3 | | | 17612 | 4 | 17667 | 4 | 1-14 | 15/16 | | | 17654 | 4 | 17628 | 4 | 17680 | 4 |

Nitro-Carb Taper Pipe Taps



| Thread | Drill Size | Taper | Flutes | Thread | Drill Size | Taper | Flutes | Thread | Drill Size | Taper | Flutes |
|--------|------------|-------|--------|--------|------------|-------|--------|--------|------------|-------|--------|
| 1/8-27 | 11/32 | 17682 | 4 | 1/4-18 | 7/16 | 17683 | 4 | 3/8-18 | 37/64 | 17684 | 4 |
| 1/2-14 | 23/32 | 17685 | 4 | 3/4-14 | 59/64 | 17686 | 5 | | | | |



Nitro-Carb Metric Taps



| Thread Size | Drill Size | Power | # of Flutes | Plug | # of Flutes | Taper | # of Flutes | Bottom | # of Flutes |
|-------------|------------|-------|-------------|-------|-------------|-------|-------------|--------|-------------|
| M2.5-.45 | 2.05 | 17704 | 2 | | | 17687 | 3 | 17750 | 3 |
| M3-.5 | 2.5 | 17705 | 2 | | | 17688 | 3 | 17751 | 3 |
| M3.5-.60 | 2.9 | 17706 | 2 | | | 17691 | 3 | 17752 | 3 |
| M4-.70 | 3.3 | 17707 | 2 | | | 17689 | 4 | 17753 | 4 |
| M4.5-.75 | 3.75 | 17719 | 2 | | | 17695 | 4 | 17771 | 4 |
| M5-.80 | 4.2 | 17708 | 2 | | | 17690 | 4 | 17754 | 4 |
| M6-1.0 | 5.0 | 17709 | 2 | | | 17692 | 4 | 17755 | 4 |
| M8-1.0* | 7.0 | | | 17768 | 4 | 17693 | 4 | 17756 | 4 |
| M8-1.25 | 6.7 | 17710 | 3 | | | 17694 | 4 | 17757 | 4 |
| M10-1.25* | 8.7 | | | 17769 | 4 | 17696 | 4 | 17758 | 4 |
| M10-1.5 | 8.5 | 17711 | 3 | | | 17697 | 4 | 17759 | 4 |
| M12-1.25* | 10.8 | | | 17770 | 4 | 17698 | 4 | 17760 | 4 |
| M12-1.75 | 10.2 | 17712 | 3 | | | 17699 | 4 | 17761 | 4 |
| M14-1.5* | 12.5 | | | 17720 | 4 | 17700 | 4 | 17762 | 4 |
| M14-2.0 | 12.0 | 17713 | 3 | | | 17701 | 4 | 17763 | 4 |
| M16-1.5* | 14.5 | | | 17721 | 4 | 17702 | 4 | 17764 | 4 |
| M16-2.0 | 14.0 | 17714 | 3 | | | 17703 | 4 | 17765 | 4 |
| M18-2.5 | 15.5 | 17772 | 3 | | | 17773 | 4 | 17774 | 4 |
| M20-2.5 | 17.5 | | | 17715 | 4 | 17717 | 4 | 17766 | 4 |
| M24-3.0 | 21.0 | | | 17716 | 4 | 17718 | 4 | 17767 | 4 |

* indicates Fine Thread

Nitro-Carb Metric Tap Sets

| IBS No. | Description |
|----------------|--|
| 17445 (P15) | 18 Metric Taps & Drill Bits w/Index Tap Sizes: M2.5-.45, M3-.5, M3.5-.60, M4-.70, M5-.80, M6-1.0, M8-1.25, M10-1.5, M12-1.75 Drill Bits: 2.05mm, 2.5mm, 2.9mm, 3.3mm, 4.2mm, 5mm, 6.7mm, 8.5mm, 10.2mm Packaged in a sturdy 18 pc. metal index |
| 567P (Z08) | 29 pc Metric Taps, Drill Bits, Hex Dies & Tools Tap Sizes: M2.5-.45, M3-.5, M3.5-.60, M4-.70, M5-.80, M6-1.0, M8-1.25, M10-1.5, M12-1.75 Includes the following tools: (1) Straight Handle Top Wrench, (1) 1" Hex Die Wrench, (1) 1-7/16" Hex Die Wrench Packaged in a sturdy 3 drawer organizer |
| 17453 | 10pc Metric Power Taps Tap Sizes: M3-.5, M3.5-.6, M4-.70, M4.5-.75, M5-.80, M6-1.0, M8-1.25, M10-1.5, M12-1.75, M16-20. Packaged in a sturdy metal index |
| 17454 | 10pc Metric Taper Taps Tap Sizes: M3-.5, M3.5-.6, M4-.70, M4.5-.75, M5-.80, M6-1.0, M8-1.25, M10-1.5, M12-1.75, M16-2.0. Packaged in a sturdy metal index |
| 17455 | 10pc Metric Bottom Taps Tap Sizes: M3-.5, M3.5-.6, M4-.7, M4.5-.75, M5-.8, M6-1.0, M8-1.25, M10-1.5, M12-1.75, M16-2.0. Packaged in a sturdy metal index |

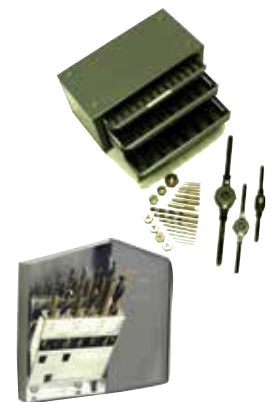

T
A
P
S

B
U
R
S

B
L
A
D
E
S



T
A
P
S

B
U
R
S

B
L
A
D
E
S

Nitro-Carb Hand Tap Assortments (P15)



| IBS No. | Description |
|---------|---|
| 551P | 10 Pc NC/NF Power Taps with Index Tap Sizes: 1/4-20, 1/4-28, 5/16-18, 5/16-24, 3/8-16, 3/8-24, 7/16-14, 7/16-20, 1/2-13, 1/2-20 Packaged in a sturdy 10 pc. metal index |
| 550P | 10 Pc NC/NF Taper Taps w/Index Tap Sizes: 1/4-20, 1/4-28, 5/16-18, 5/16-24, 3/8-16, 3/8-24, 7/16-14, 7/16-20, 1/2-13, 1/2-20 Packaged in a sturdy 10 pc. metal index |
| 552P | 10 Pc NC/NF Bottom Taps w/Index Tap Sizes: 1/4-20, 1/4-28, 5/16-18, 5/16-24, 3/8-16, 3/8-24, 7/16-14, 7/16-20, 1/2-13, 1/2-20 Packaged in a sturdy 10 pc. metal index |
| 554P | 10 Pc NC Power Taps with Index Tap Sizes: 4-40, 6-32, 8-32, 10-24, 10-32, 1/4-20, 5/16-18, 3/8-16, 1/2-13, 5/8-11 Packaged in a sturdy 10 pc. metal index |
| 553P | 10 Pc NC Taper Taps with Index Tap Sizes: 4-40, 6-32, 8-32, 10-24, 10-32, 1/4-20, 5/16-18, 3/8-16, 1/2-13, 5/8-11 Packaged in a sturdy 10 pc. metal index |
| 555P | 10 Pc NC Bottom Taps with Index Tap Sizes: 4-40, 6-32, 8-32, 10-24, 10-32, 1/4-20, 5/16-18, 3/8-16, 1/2-13, 5/8-11 Packaged in a sturdy 10 pc. metal index |
| 17448 | 18 Pc NC Power Taps & Drill Bits with Index Tap Sizes: 6-32, 8-32, 10-24, 10-32, 1/4-20, 5/16-18, 3/8-16, 7/16-14, 1/2-13 Drill Bits: #36, #29, #25, #21, #7, "F", 5/16" "U", 27/64" Packaged in a sturdy 18 pc. metal index |
| 17447 | 18 Pc NC Taper Taps & Drill Bits with Index Tap Sizes: 6-32, 8-32, 10-24, 10-32, 1/4-20, 5/16-18, 3/8-16, 7/16-14, 1/2-13 Drill Bits: #36, #29, #25, #21, #7, "F", 5/16" "U", 27/64" Packaged in a sturdy 18 pc. metal index |
| 17449 | 18 Pc NC Bottom Taps & Drill Bits with Index Tap Sizes: 6-32, 8-32, 10-24, 10-32, 1/4-20, 5/16-18, 3/8-16, 7/16-14, 1/2-13 Drill Bits: #36, #29, #25, #21, #7, "F", 5/16" "U", 27/64" Packaged in a sturdy 18 pc. metal index |

Nitro-Carb Power Tap & Hex Die Sets

- **Special Hi-Tungsten and Hi-Molybdenum tool steel construction, gold surface treated** for maximum lubricity.
- **Recommended for use in production tapping and drilling** in work hardening grades of stainless steel and other hard metal applications.
- **Precision ground tap threads** for the ultimate in accuracy and performance.



40 Pc NITRO-CARB POWER TAP & HEX DIE SET

| IBS No. | Description |
|---------|--|
| 17472 | SET CONTAINS: <ul style="list-style-type: none"> • Nitro Power Taps & Hex Die Sizes: 4-40, 6-32, 8-32, 10-24, 10-32, 12-24, 1/4-20, 1/4-28, 5/16-18, 5/16-24, 3/8-16, 3/8-24, 7/16-14, 7/16-20, 1/2-13 & 1/2-20 • Nitro-Carb Taper Pipe Tap & Hex Die: 1/8-27 NPT • T-Handle tap wrenches: 0" - 1/4" & 3/16" - 1/2" • Straight handle tap wrench: #4 - 1/2" • Die stock, screw pitch gauge & screwdriver. • Packaged in a sturdy molded plastic case. |



25 Pc NITRO-CARB POWER TAP & HEX DIE SET

| IBS No. | Description |
|---------|--|
| 17471 | SET CONTAINS: <ul style="list-style-type: none"> • Nitro Power Taps & Hex Die Sizes: 1/4-20, 1/4-28, 5/16-18, 5/16-24, 3/8-16, 3/8-24, 7/16-14, 7/16-20, 1/2-13 & 1/2-20. • Nitro-Carb Pipe Tap & Hex Die Size: 1/8-27 NPT • T-Handle tap wrench: 3/16" - 1/2" • Die stock, screw pitch gauge & screwdriver. • Packaged in a sturdy molded plastic case. |





#4 thru 1/2 Tap, Die & Drill Set

NITRO-CARB TAPS WITH TAP & DIE WRENCHES

Packaged in a Locking Steel Drawer for Easy Storage & Organization

IBS No. 591P • 50 Items • 50 Pcs



|  IBS, Inc. <small>SPECIALTY PRODUCTS FOR MAINTENANCE & REPAIR INDUSTRIALBOLT.COM © 2013 800-678-1906</small> | | Nitro-Carb Power Taps, Hex Dies and Drill Bits with Tools | |
|--|---------|---|---------|
| | | Assortment No. 591P | |
| 120922 Professional Tap Wrench  | | 120925 Professional 1" Hex Die Wrench  | |
| 129913 HSS Hex Die 17643 Nitro-Carb Power Tap 16823 27/64 Drill Bit | 1/2-13 | 129922 HSS Hex Die 17644 Nitro-Carb Power Tap 16825 29/64 Drill bit | 1/2-20 |
| 129912 HSS Hex Die 17641 Nitro-Carb Power Tap 16155 "U" Drill Bit | 7/16-14 | 129921 HSS Hex Die 17642 Nitro-Carb Power Tap 16821 25/64 Drill Bit | 7/16-20 |
| 129910 HSS Hex Die 17637 Nitro-Carb Power Tap 16140 "F" Drill Bit | 5/16-18 | 129919 HSS Hex Die 17638 Nitro-Carb Power Tap 16143 "I" Drill Bit | 5/16-24 |
| 129917 HSS Hex Die 17633 Nitro-Carb Power Tap 16100 #21 Drill Bit | 10-32 | 129908 HSS Hex Die 17634 Nitro-Carb Power Tap 16095 #16 Drill Bit | 12-24 |
| 129904 HSS Hex Die 17629 Nitro-Carb Taper Tap 16122 #43 Drill Bit | 4-40 | 129905 HSS Hex Die 17630 Nitro-Carb Power Tap 16115 #36 Drill Bit | 6-32 |
| 129911 HSS Hex Die 17639 Nitro-Carb Power Tap 16149 "O" Drill Bit | 3/8-16 | 129909 HSS Hex Die 17635 Nitro-Carb Power Tap 16086 #7 Drill Bit | 1/4-20 |
| 129920 HSS Hex Die 17640 Nitro-Carb Power Tap 16151 "Q" Drill Bit | 3/8-24 | 129918 HSS Hex Die 17636 Nitro-Carb Power Tap 16082 #3 Drill Bit | 1/4-28 |
| 129906 HSS Hex Die 17631 Nitro-Carb Power Tap 16108 #29 Drill Bit | 8-32 | 129907 HSS Hex Die 17632 Nitro-Carb Power Tap 16104 #25 Drill Bit | 10-24 |



9/16 thru 3/4 Tap, Die & Drill Set

NITRO-CARB TAPS WITH TAP & DIE WRENCHES

Packaged in a Locking Steel Drawer for Easy Storage & Organization

IBS No. 592P • 50 Items • 50 Pcs



|  IBS, Inc. <small>SPECIALTY PRODUCTS FOR MAINTENANCE & REPAIR INDUSTRIALBOLT.COM © 2013 800-678-1906</small> | | Nitro-Carb Plug/Power Taps, Hex Dies and Drill Bits with Tools | |
|--|---------|---|---------|
| | | Assortment No. 592P | |
| 120923 Professional Tap Wrench  | | 120926 Professional 1-7/16" Hex Die Wrench  | |
| 129916 HSS Hex Die 17649 Nitro-Carb Power Tap 16842 21/32 Drill Bit | 3/4-10 | 129925 HSS Hex Die 17650 Nitro-Carb Power Tap 16844 11/16 Drill bit | 3/4-16 |
| 129915 HSS Hex Die 17647 Nitro-Carb Power Tap 16834 17/32 Drill Bit | 5/8-11 | 129924 HSS Hex Die 17648 Nitro-Carb Power Tap 16836 9/16 Drill bit | 5/8-18 |
| 129914 HSS Hex Die 17645 Nitro-Carb Plug Tap 16827 31/64 Drill Bit | 9/16-12 | 129923 HSS Hex Die 17646 Nitro-Carb Plug Tap 16828 1/2 Drill bit | 9/16-18 |

TAPS
BURS
BLADES



IBS, INCORPORATED

Assortments Z08

Metric Nitro-Carb Power Taps, Drill Bits & Tap & Die Tools

NITRO-CARB TAPS

Packaged in a Locking Steel Drawer for Easy Storage & Organization

IBS No. 593P • 29 Items • 29 Pcs



T
A
P
S





B
U
R
S

B
L
A
D
E
S

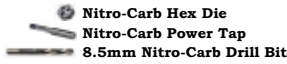
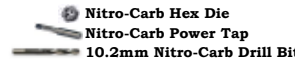
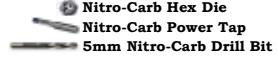
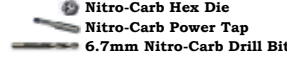
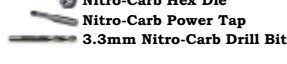
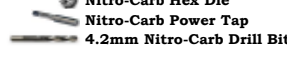
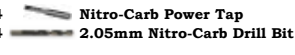

Metric Nitro-Carb Power Taps, Hex Dies and Drill Bits w/ Tools

Assortment No. 593P

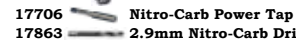
| | | | |
|--|---|---|--|
| <p>120925 Professional 1" Hex Die Wrench</p>  | | <p>120926 Professional 1" Hex Die Wrench</p>  | |
| <p>120922 Professional Tap Wrench</p>  | | | |
| <p>M10-1.5 129934 Nitro-Carb Hex Die 17711 Nitro-Carb Power Tap 17919 8.5mm Nitro-Carb Drill Bit</p>  | | <p>M12-1.75 129935 Nitro-Carb Hex Die 17712 Nitro-Carb Power Tap 17936 10.2mm Nitro-Carb Drill Bit</p>  | |
| <p>M6-1.0 129931 Nitro-Carb Hex Die 17709 Nitro-Carb Power Tap 17884 5mm Nitro-Carb Drill Bit</p>  | | <p>M8-1.25 129933 Nitro-Carb Hex Die 17710 Nitro-Carb Power Tap 17901 6.7mm Nitro-Carb Drill Bit</p>  | |
| <p>M4-0.7 129929 Nitro-Carb Hex Die 17707 Nitro-Carb Power Tap 17867 3.3mm Nitro-Carb Drill Bit</p>  | | <p>M5-0.8 129930 Nitro-Carb Hex Die 17708 Nitro-Carb Power Tap 17876 4.2mm Nitro-Carb Drill Bit</p>  | |
| <p>M2.5-0.45 17704 Nitro-Carb Power Tap 17854 2.05mm Nitro-Carb Drill Bit</p>  | <p>M3-0.5 129928 Nitro-Carb Hex Die 17705 Nitro-Carb Power Tap 17859 2.5mm Nitro-Carb Drill Bit</p>  | <p>M3.5-0.6 135590 Nitro-Carb Hex Die 17706 Nitro-Carb Power Tap 17863 2.9mm Nitro-Carb Drill Bit</p>  | |

Nitro-Carb Power Tap & Hex Die Sets

- **Special Hi-Tungsten and Hi-Molybdenum tool steel construction, gold surface treated** for maximum lubricity.
- **Recommended for use in production tapping and drilling** in work hardening grades of stainless steel and other hard metal applications.
- **Precision ground tap threads** for the ultimate in accuracy and performance.



24Pc METRIC NITRO-CARB POWER TAP & HEX DIE SET

| IBS No. | Description |
|---------|---|
| 17474 | SET CONTAINS: |
| | <ul style="list-style-type: none"> • Nitro Power Taps & Hex Die Sizes: 3.0-.50, 3.5-.60, 4.0-.70, 5.0-.80, 6.0-1.00, 8.0-1.25, 10.0-1.50 & 12.0-1.75. • HSS pipe tap & hex die size: 1/8-27 NPT • T-Handle tap wrenches: 0" - 1/4" & 3/16" - 1/2" • Straight handle tap wrench: #4 - 1/2" • Die stock & screw metric pitch gauge. • Packaged in a sturdy molded plastic case. |



Professional Straight Handle Tap Wrench (T03)

- Solid construction for long life and ease of use.
- Straight handle design provides greater leverage, especially when using larger diameter taps.
- Ideal for hand tapping.



| IBS No. | Description |
|---------|--|
| 120922 | For Taps #0 to 1/2" (3mm to 12mm) |
| 120923 | For Taps #1/4" to 3/4" (6mm to 18mm) |
| 120924 | For Taps #1/2 to 1-1/8" (12mm to 28mm) |

Professional Hex Die Wrench (T03)

- Maintains alignment for accurate, straight threading.
- Dies easily lock in position with set screw



| IBS No. | Description |
|---------|-------------------------|
| 120925 | For 1" Hexagon Dies |
| 120926 | For 1-7/16 Hexagon Dies |

T-Handle Tap Wrench

- Designed for use with taps and on many other tools to be turned by hand.
- Adjusted and tightened to size by twisting knurled nut.
- Sliding T-Wrench Handle.
- Additional holding jaws are recessed and inside hole for trapping onto small sized taps.
- T-Handle may be extended full length in either direction for more leverage.
- Sliding T-handle has spring tension stop.



| IBS No. | Description |
|---------|--------------------------------------|
| 120920 | For Taps #0 to 1/4" (3mm to 6mm) |
| 120921 | For Taps #3/16 to 1/2" (4mm to 12mm) |

T-Handle Ratcheting Tap Wrenches

- Adjustable T-Handle may be slipped from side to side for positioning convenience and added leverage in tight spaces.
- It can be easily set for left or right handed operation, or locked for non-ratcheting use.
- Available in sizes to fit 1/16" up to 1/2" taps, and in extended lengths up to 12" for hard-to-reach areas.
- Designed for use with taps, reamers, screw extractors and other tools with a square shank.



| IBS No. | Description |
|---------|--------------------------------------|
| 120930 | 1/16 -1/4 Ratcheting Tap Wrench |
| 120931 | 1/4 -1/2 Ratcheting Tap Wrench |
| 120932 | 1/16 -1/4 x 10 Ratcheting Tap Wrench |
| 120933 | 1/4 -1/2 x 12 Ratcheting Tap Wrench |

Tapping Tool & Guide

Perfect alignment provided for close tolerances and perpendicularity between the hardened sleeve of the tapper and the inside of the tapping guide.

Stops tap breakage.

- Carbonitrided jaws for long life.
- Center drill on stem for floating center.
- Sliding T-Wrench Handle.
- 120° Vees on Aligner Body Base to accept round parts.
- Slotted body serves as wrench for tightening when changing jaws.



| IBS No. | Description |
|---------|----------------------|
| 17050 | Tapping Tool & Guide |

T
A
P
S

B
U
R
S

B
L
A
D
E
S



IBS, INCORPORATED

Nitro-Carb Hex Dies P10

Nitro-Carb Hex Dies

T
A
P
S
B
U
R
S
B
L
A
D
E
S

- Hi-Molybdenum tool steel construction for maximum life.
- Nitro-Carburized finish at 950°F to be measurably harder than high speed steel.
- Nitro-Carb dies are designed to last 5 times longer than their carbon steel equivalent.
- Polished gold flats with black surface treated threads for long life and rich appearance.
- Hex configuration allows both wrench and die stock use in threading — more universal than round dies.
- 4-40 through 1/2" have a 1" O.D.; 9/16" through 3/4" have a 1-7/16" O.D.



COARSE THREAD

| IBS No. | Thread | Width Across Flats | Die Wrench |
|---------|---------|--------------------|------------|
| 129904 | 4-40 | 1" Hex | 120925 |
| 129905 | 6-32 | 1" Hex | 120925 |
| 129906 | 8-32 | 1" Hex | 120925 |
| 129907 | 10-24 | 1" Hex | 120925 |
| 129908 | 12-24 | 1" Hex | 120925 |
| 129909 | 1/4-20 | 1" Hex | 120925 |
| 129910 | 5/16-18 | 1" Hex | 120925 |
| 129911 | 3/8-16 | 1" Hex | 120925 |
| 129912 | 7/16-14 | 1" Hex | 120925 |
| 129913 | 1/2-13 | 1" Hex | 120925 |
| 129914 | 9/16-12 | 1-7/16" Hex | 120926 |
| 129915 | 5/8-11 | 1-7/16" Hex | 120926 |
| 129916 | 3/4-10 | 1-7/16" Hex | 120926 |

PIPE THREAD

| IBS No. | Thread | Width Across Flats | Die Wrench |
|---------|------------|--------------------|------------|
| 129926 | 1/8 NPT | 1" Hex | 120925 |
| 129927 | 1/4-18 NPT | 1-7/16" Hex | 120926 |



FINE THREAD

| IBS No. | Thread | Width Across Flats | Die Wrench |
|---------|---------|--------------------|------------|
| 129917 | 10-32 | 1" Hex | 120925 |
| 129918 | 1/4-28 | 1" Hex | 120925 |
| 129919 | 5/16-24 | 1" Hex | 120925 |
| 129920 | 3/8-24 | 1" Hex | 120925 |
| 129921 | 7/16-20 | 1" Hex | 120925 |
| 129922 | 1/2-20 | 1" Hex | 120925 |
| 129923 | 9/16-18 | 1-7/16" Hex | 120926 |
| 129924 | 5/8-18 | 1-7/16" Hex | 120926 |
| 129925 | 3/4-16 | 1-7/16" Hex | 120926 |



METRIC THREAD

| IBS No. | Thread | Width Across Flats | Die Wrench |
|---------|----------|--------------------|------------|
| 129928 | M3-.05 | 1" Hex | 120925 |
| 135590 | M3.5-.60 | 1" Hex | 120925 |
| 129929 | M4-.07 | 1" Hex | 120925 |
| 129930 | M5-.08 | 1" Hex | 120925 |
| 129931 | M6-1.0 | 1" Hex | 120925 |
| 129933 | M8-1.25 | 1" Hex | 120925 |
| 129934 | M10-1.5 | 1" Hex | 120925 |
| 129935 | M12-1.75 | 1-7/16" Hex | 120926 |

Nitro Carb Hex Dies are sold in packages of 1



IBS Carbide Tipped Annular Cutters 1-3/8" & 2" Cutting Depth

IBS carbide tipped annular cutters maximize the cutting performance of any portable magnetic drill press. Their superior "Triple Edge" cutting action outperforms ordinary high speed steel annular cutters and twist drills 6 to 1.

Annular cutters offer an alternative to reaming and can be used in applications where hole saws are limited by depth.

Ideal for making large holes in thick steel.

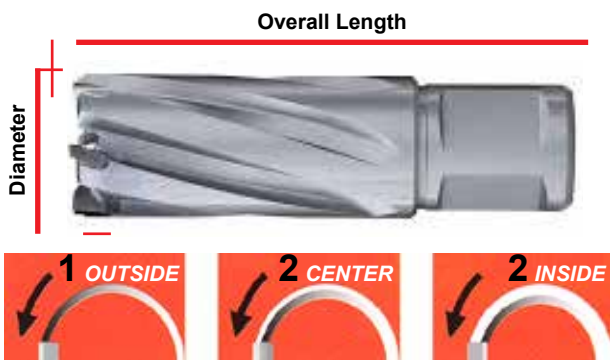

Triple Edge Cutters — Superior ultra-hard tungsten carbide tips, balanced in three different positions permit higher feed rates and increased hole making in structural steel and steel plate.

Features & Benefits:

- Ultra-hard tungsten carbide teeth permit faster cutting even in tough materials and shapes.
- Cut clean, bur-free holes; precision pilot ejects the center as a plug of steel.
- Features "Weldon-style" flats for fast loading and better rigidity.

Applications:

- For use with magnetic drill presses to cut holes in cast iron steel, and ultra-hard or exotic alloys.
- 1-3/8" Cutting Depth — for drilling holes up to 1-3/8" deep and 9/16" to 2-1/16" diameter.
- 2" Cutting Depth — for drilling holes up to 2" deep and 9/16" to 2 1/16" diameter with high precision and speed.
- Produce overlapping and interrupted holes easily.
- Ideal for crescent cuts on pipe ends.



1-3/8" Carbide Tipped

2" Carbide Tipped

| IBS No. | Size | Usable Length | IBS No. | Size | Usable Length |
|--------------|---------|---------------|--------------|---------|---------------|
| 19102 | 9/16 | 1" | 19132 | 9/16 | 2" |
| 19103 | 5/8 | 1" | 19133 | 5/8 | 2" |
| 19104 | 11/16 | 1" | 19134 | 11/16 | 2" |
| 19105 | 3/4 | 1" | 19135 | 3/4 | 2" |
| 19106 | 13/16 | 1" | 19136 | 13/16 | 2" |
| 19107 | 7/8 | 1" | 19137 | 7/8 | 2" |
| 19108 | 15/16 | 1" | 19138 | 15/16 | 2" |
| 19109 | 1 | 1" | 19139 | 1 | 2" |
| 19110 | 1-1/16 | 1" | 19140 | 1-1/16 | 2" |
| 19111 | 1-1/8 | 1" | 19141 | 1-1/8 | 2" |
| 19112 | 1-3/16 | 1" | 19142 | 1-3/16 | 2" |
| 19113 | 1-1/4 | 1" | 19143 | 1-1/4 | 2" |
| 19114 | 1-5/16 | 1" | 19144 | 1-5/16 | 2" |
| 19115 | 1-3/8 | 1" | 19145 | 1-3/8 | 2" |
| 19116 | 1-7/16 | 1" | 19146 | 1-7/16 | 2" |
| 19117 | 1-1/2 | 1" | 19147 | 1-1/2 | 2" |
| 19118 | 1-9/16 | 1" | 19148 | 1-9/16 | 2" |
| 19119 | 1-5/8 | 1" | 19149 | 1-5/8 | 2" |
| 19120 | 1-11/16 | 1" | 19150 | 1-11/16 | 2" |
| 19121 | 1-3/4 | 1" | 19151 | 1-3/4 | 2" |
| 19122 | 1-13/16 | 1" | 19152 | 1-13/16 | 2" |
| 19123 | 1-7/8 | 1" | 19153 | 1-7/8 | 2" |
| 19124 | 1-15/16 | 1" | 19154 | 1-15/16 | 2" |
| 19125 | 2 | 1" | 19155 | 2 | 2" |
| 19126 | 2-1/16 | 1" | 19156 | 2-1/16 | 2" |

1-3/8" Accessories

2" Accessories

| | | | |
|--------------|-------------------------------|--------------|-------------------------------|
| 19339 | Pilot Pin for 7/16" & 1/2" | 19453 | Pilot Pin for 7/16" & 1/2" |
| 19345 | Pilot Pin for 9/16" or larger | 19470 | Pilot Pin for 9/16" or larger |

All IBS part numbers in **bold print** are stock items
All IBS part numbers not in **bold print** require 1 week lead time

T
A
P
S
B
U
R
S
B
L
A
D
E
S



Carbide Tipped Annular Cutter Sets

1" & 2" Cutting Depth
6 Pc Sets

Packaged a Molded Plastic Case for Easy Storage
& Organization



1" CARBIDE TIPPED ANNULAR CUTTER SET
IBS No. 19465

| IBS No. | Size | Usable Length |
|---------|------------------|---------------|
| 19104 | 11/16 | 1" |
| 19106 | 13/16 | 1" |
| 19108 | 15/16 | 1" |
| 19109 | 1 | 1" |
| 19110 | 1-1/16 | 1" |
| 19435 | Pilot Pin for 1" | |



2" CARBIDE TIPPED ANNULAR CUTTER SET
IBS No. 19466

| IBS No. | Size | Usable Length |
|---------|------------------|---------------|
| 19134 | 11/16 | 2" |
| 19136 | 13/16 | 2" |
| 19138 | 15/16 | 2" |
| 19139 | 1 | 2" |
| 19140 | 1-1/16 | 2" |
| 19470 | Pilot Pin for 2" | |

T
A
P
S

B
U
R
S

B
L
A
D
E
S



IBS High Speed Steel Annular Cutters

1" & 2" Cutting Depth

IBS High Speed Steel Annular Cutters are made in the USA and are the highest quality cutters available on the market. The exclusive CNC machining and heat treating process used to manufacture IBS cutters provide extreme drilling performance, ensuring longer cutter life and efficient hole drilling, while maintaining precise bore tolerances.



- IBS HSS Annular Cutters come **WITH a pilot pin**, eliminating the need for finding and assembling for improved productivity and faster change-outs, saving time and money.
- **MADE IN THE USA of high quality M2 Steel** for optimum performance for longer life and more cuts in standard steel drilling applications, saving time and money.
- **HSS is non-sensitive to shock or impact** as compared to carbide — making them more durable in applications not requiring carbide.
- Stocked in 1" and 2" depth of cut, (also available NONSTOCK in 3" depth).

PILOT PINS

- Pilot pin included with cutter
- Allow coolant to flow to center of cutter during drilling cycle.
- Eject slug from center of cutter after the drilling cycle.
- Align cutters to desired drilling position.

| 1" Cutter | | | 2" Cutter | | |
|-----------|---------|---------------|-----------|---------|---------------|
| IBS No. | Size | Usable Length | IBS No. | Size | Usable Length |
| 19396 | 7/16 | 1" | 19426 | 7/16 | 2" |
| 19397 | 1/2 | 1" | 19427 | 1/2 | 2" |
| 19346 | 9/16 | 1" | 19471 | 9/16 | 2" |
| 19347 | 5/8 | 1" | 19472 | 5/8 | 2" |
| 19348 | 11/16 | 1" | 19473 | 11/16 | 2" |
| 19349 | 3/4 | 1" | 19474 | 3/4 | 2" |
| 19350 | 13/16 | 1" | 19475 | 13/16 | 2" |
| 19351 | 7/8 | 1" | 19476 | 7/8 | 2" |
| 19352 | 15/16 | 1" | 19477 | 15/16 | 2" |
| 19353 | 1 | 1" | 19478 | 1 | 2" |
| 19354 | 1-1/16 | 1" | 19479 | 1-1/16 | 2" |
| 19355 | 1-1/8 | 1" | 19480 | 1-1/8 | 2" |
| 19356 | 1-3/16 | 1" | 19481 | 1-3/16 | 2" |
| 19357 | 1-1/4 | 1" | 19482 | 1-1/4 | 2" |
| 19358 | 1-5/16 | 1" | 19483 | 1-5/16 | 2" |
| 19359 | 1-3/8 | 1" | 19484 | 1-3/8 | 2" |
| 19360 | 1-7/16 | 1" | 19485 | 1-7/16 | 2" |
| 19361 | 1-1/2 | 1" | 19486 | 1-1/2 | 2" |
| 19362 | 1-9/16 | 1" | 19487 | 1-9/16 | 2" |
| 19363 | 1-5/8 | 1" | 19488 | 1-5/8 | 2" |
| 19364 | 1-11/16 | 1" | 19489 | 1-11/16 | 2" |
| 19365 | 1-3/4 | 1" | 19490 | 1-3/4 | 2" |
| 19366 | 1-13/16 | 1" | 19491 | 1-13/16 | 2" |
| 19367 | 1-7/8 | 1" | 19492 | 1-7/8 | 2" |
| 19368 | 1-15/16 | 1" | 19493 | 1-15/16 | 2" |
| 19369 | 2 | 1" | 19494 | 2 | 2" |
| 19370 | 2-1/16 | 1" | 19495 | 2-1/16 | 2" |

| 1" Accessories | | 2" Accessories | |
|----------------|------------------------------|----------------|-------------------------------|
| 19339 | Pilot Pin for 7/16" & 1/2" | 19453 | Pilot Pin for 7/16" & 1/2" |
| 19345 | Pilot Pin for 9/16" or large | 19470 | Pilot Pin for 9/16" or larger |

T
A
P
S
B
U
R
S
B
L
A
D
E
S



IBS, INCORPORATED

Hole Saws & Cutters P15

IBS High Speed Steel Annular Cutter 6 & 12 Pc Sets

1" & 2" Cutting Depth

Packaged in a Molded Plastic Case for Easy Storage & Organization



6 PC 1" IBS HSS ANNULAR CUTTER SET
IBS No. 19420

| IBS No. | Size | Usable Length |
|---------|------------------------------|---------------|
| 19346 | 9/16 | 1" |
| 19348 | 11/16 | 1" |
| 19350 | 13/16 | 1" |
| 19352 | 15/16 | 1" |
| 19354 | 1-1/16 | 1" |
| 19345 | Pilot Pin for 9/16 or larger | |



6 PC 2" IBS HSS ANNULAR CUTTER SET
IBS No. 19422

| IBS No. | Size | Usable Length |
|---------|------------------------------|---------------|
| 19471 | 9/16 | 2" |
| 19473 | 11/16 | 2" |
| 19475 | 13/16 | 2" |
| 19477 | 15/16 | 2" |
| 19479 | 1-1/16 | 2" |
| 19470 | Pilot Pin for 9/16 or larger | |



12 PC 1" IBS HSS ANNULAR CUTTER SET
IBS No. 19421

| IBS No. | Size | Usable Length |
|---------|------------------------------|---------------|
| 19396 | 7/16 | 1" |
| 19397 | 1/2 | 1" |
| 19346 | 9/16 | 1" |
| 19347 | 5/8 | 1" |
| 19348 | 11/16 | 1" |
| 19349 | 3/4 | 1" |
| 19350 | 13/16 | 1" |
| 19351 | 7/8 | 1" |
| 19352 | 15/16 | 1" |
| 19353 | 1 | 1" |
| 19354 | 1-1/16 | 1" |
| 19339 | Pilot Pin for 7/16" & 1/2" | |
| 19345 | Pilot Pin for 9/16 or larger | |



12 PC 2" IBS HSS ANNULAR CUTTER SET
IBS No. 19423

| IBS No. | Size | Usable Length |
|---------|------------------------------|---------------|
| 19426 | 7/16 | 2" |
| 19427 | 1/2 | 2" |
| 19471 | 9/16 | 2" |
| 19472 | 5/8 | 2" |
| 19473 | 11/16 | 2" |
| 19474 | 3/4 | 2" |
| 19475 | 13/16 | 2" |
| 19476 | 7/8 | 2" |
| 19477 | 15/16 | 2" |
| 19478 | 1" | 2" |
| 19479 | 1-1/16 | 2" |
| 19453 | Pilot Pin for 7/16" & 1/2" | |
| 19470 | Pilot Pin for 9/16 or larger | |

T
A
P
S

B
U
R
S

B
L
A
D
E
S

Hole Saws & Cutters P28

M42 Thin Wall Hole Saws



M42 THIN WALL HOLE SAWS

| IBS No. | Description |
|---------|-------------------------------|
| 29290 | 3/4" M42 Thin Wall Hole Saw |
| 29291 | 7/8" M42 Thin Wall Hole Saw |
| 29292 | 1" M42 Thin Wall Hole Saw |
| 29293 | 1-1/8" M42 Thin Wall Hole Saw |
| 29294 | 1-1/4" M42 Thin Wall Hole Saw |
| 29295 | 1-3/8" M42 Thin Wall Hole Saw |
| 29296 | 1-1/2" M42 Thin Wall Hole Saw |
| 4CREDIT | Used Trade-A-Blade Credit |

- Innovative Design** — Impact rated hole cutter makes these far more aggressive at cutting sheet metal and other thin metals. Rated for impact tools and coupled with thin all, these cut many times faster than a standard hole saw or special sheet metal hole cutter like the slugger.
- 1/4" Hex Shank Quick Change Versatility** — Can be used with a wide range of air, corded or cordless tools, including impact tools. Can be used with hex shank adaptors, quick releases and extensions.
- Thin Wall** — The thin wall 3TPI design makes these hole saws cut extremely fast compared to other hole saws that have to remove more material due to the thicker wall design. They leave a burr-free cut that is faster and cleaner than standard bi-metal hole saws.
- M42 Bi-Metal with 8% Cobalt** — M42 Bi-Metal with Cobalt has increased wear resistance and added tooth strength. This combination has proven to be excellent for steel and metal cutting applications across several platforms (bandsaw, recip, etc.). M42 Bi-Metal is highly resistant to wear or breakage so it stays sharp longer and provides a fast cutting over a long life.
- Built-in pilot drill with spring** for immediate slug ejection — unlike most hole saws that require effort after the cut to remove the slug, the ejection spring makes slug removal fast and effortless, boosting productivity.
- Stop shoulder design** has built-in collar to prevent the saw from over-drilling or popping through the work — preventing damage to things like electrical wires and components when drilling through existing panels in service equipment.
- Optimized for applications in thin gauge metal** up to 1/8" thick.

NOTE: Our Trade-a-Blade™ system is simple! The Trade-a-Blade™ system rewards our users by giving them a 'Trade Credit' toward the purchase of another Trade-a-Blade™ product. This is an easy and a cost effective way for customers to save money.

Receive a \$4 credit toward the purchase of a new M42 Thin Wall Hole Saw when turning in a used one.

Limit - One \$4 credit for each new M42 Thin Wall Hole Saw purchased.

The used M42 Thin Wall Hole Saws can be turned into your salesperson for credit when placing an order for a new one. The \$4 credit will be reflected on the invoice with the new M42 Thin Wall Hole Saws.



M42 Thin Wall Hole Saws Travel Tray Assortment PACKAGED IN A PLASTIC TRAVEL TRAY IBS No. 820R • 7 Items • 7 Pcs

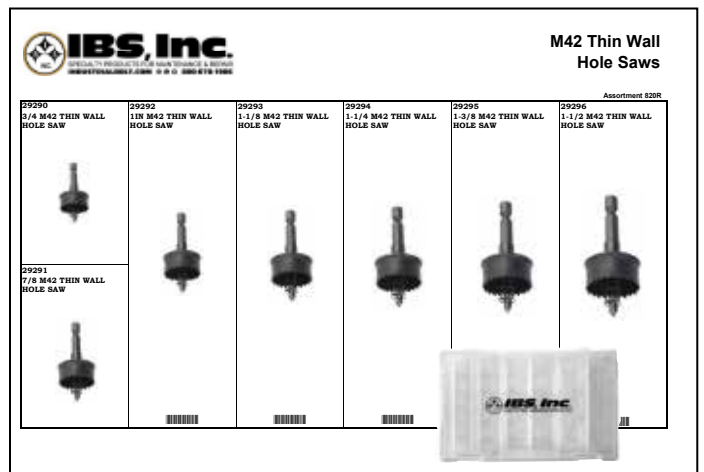

T
A
P
S
B
U
R
S
B
L
A
D
E
S



IBS, INCORPORATED

Hole Saws & Cutters P28

Carbide Tipped Cutters

For Thin Steel Applications — Up to 3/16" Thick

The fastest and smoothest way to cut holes in thin steel, these carbide tipped hole saws are the perfect workmate for the professional electrician, plumber, mechanic and general contractor.



Features & Benefits:

- **Built-in ejector spring and pilot drill** — for quick smooth discharge of metal slug and optimal productivity.
- **Special Tungsten Carbide Teeth** provide increased wear resistance resulting in a saw that will **outlast and outperform** traditional bi-metal saws, step drills, and other tools by as much as **10 to 1**.
- **Carbide Teeth Cut Clean** — which means less resistance and up to three times less energy drained when using a cordless drill, for more cuts in a charge — saving time and money.
- **Safety Collar Stop**—prevents over penetration of the work piece and provides better rigidity for clean, bur-free cutting with quicker and easier removal.
- **One Piece Construction** —for stable, accurate cutting, resulting in crisp cuts without burrs.

Applications:

- **Quickly cuts holes in materials up to 3/16" thick**

| | |
|------------------|-----------------|
| Thin Steel Plate | Iron |
| Aluminum | Copper |
| Cast Iron | Stainless Steel |
- **Cleanly cuts holes (9/16 up to 5" diameter) in:**

| | |
|-------------------|-----------------------|
| Junction Boxes | Switch Boxes |
| Metal Studs | Electrical Appliances |
| Lighting Fixtures | Pipe |

Ideal for auto, truck & body repair
- **Producing overlapping and uninterrupted holes easily.**

CARBIDE TIPPED CUTTERS CUTS 3/16" DEPTH

Includes Hole Saw, Arbor and Pilot Drill

| IBS No. | Shank | Cut | IBS No. | Shank | Cut |
|---------|-------|---------|---------|-------|---------|
| 19200 | 3/8" | 9/16 | 19226 | 3/8" | 2-3/16 |
| 19201 | 3/8" | 5/8 | 19227 | 3/8" | 2-1/4 |
| 19202 | 3/8" | 11/16 | 19228 | 3/8" | 2-5/16 |
| 19203 | 3/8" | 3/4 | 19229 | 3/8" | 2-3/8 |
| 19204 | 3/8" | 13/16 | 19230 | 3/8" | 2-7/16 |
| 19205 | 3/8" | 7/8 | 19231 | 3/8" | 2-1/2 |
| 19206 | 3/8" | 15/16 | 19232 | 3/8" | 2-9/16 |
| 19207 | 3/8" | 1 | 19233 | 3/8" | 2-5/8 |
| 19208 | 3/8" | 1-1/16 | 19234 | 1/2" | 2-11/16 |
| 19209 | 3/8" | 1-1/8 | 19235 | 1/2" | 2-3/4 |
| 19210 | 3/8" | 1-3/16 | 19236 | 1/2" | 2-13/16 |
| 19211 | 3/8" | 1-1/4 | 19237 | 1/2" | 2-7/8 |
| 19212 | 3/8" | 1-5/16 | 19238 | 1/2" | 2-5/16 |
| 19213 | 3/8" | 1-3/8 | 19239 | 1/2" | 3 |
| 19214 | 3/8" | 1-7/16 | 1923902 | 1/2" | 3-1/4 |
| 19215 | 3/8" | 1-1/2 | 1923903 | 1/2" | 3-3/8 |
| 19216 | 3/8" | 1-9/16 | 1923904 | 1/2" | 3-1/2 |
| 19217 | 3/8" | 1-5/8 | 1923906 | 1/2" | 3-3/4 |
| 19218 | 3/8" | 1-11/16 | 1923908 | 1/2" | 4 |
| 19219 | 3/8" | 1-3/4 | 1923909 | 1/2" | 4-1/8 |
| 19220 | 3/8" | 1-13/16 | 1923910 | 1/2" | 4-1/4 |
| 19221 | 3/8" | 1-7/8 | 1923912 | 1/2" | 4-1/2 |
| 19222 | 3/8" | 1-15/16 | 1923913 | 1/2" | 4-3/4 |
| 19223 | 3/8" | 2 | 1923914 | 1/2" | 5 |
| 19224 | 3/8" | 2-1/16 | | | |
| 19225 | 3/8" | 2-1/8 | | | |

CT CUTTERS™ 3/16" Depth ACCESSORIES

| | |
|-------|---|
| 19240 | Pilot Drill |
| 19241 | Ejector Spring - 3/16" Depth |
| 19242 | Pilot Drill - Carbide Tipped for Ductile Pipe |

T
A
P
S

B
U
R
S

B
L
A
D
E
S

Carbide Tipped Hole Cutters For Thick Steel Applications Up to 1" Thick

The ultimate way to cut holes in thick steel, this long tip carbide hole saw is the new "Contractor's Helper." Cutting quick, accurate holes in pipe or drilling through thick steel are no longer a problem with the triple edge cutting power of our Carbide Tipped Hole Cutters.



Features & Benefits:

- **Built-in ejector spring and pilot drill** — for quick smooth discharge of metal slug and optimal productivity.
- **Special Tungsten Carbide Teeth** provide increased wear resistance resulting in a saw that will **outlast and outperform** traditional bi-metal saws, step drills, and other tools by as much as **10 to 1**.
- **Carbide Teeth Cut Clean** — which means less resistance and up to three times less energy drained when using a cordless drill, for more cuts in a charge — saving time and money.
- **Safety Collar Stop** — prevents over penetration of the work piece and provides better rigidity for clean, bur-free cutting with quicker and easier removal.
- **One Piece Construction** —for stable, accurate cutting, resulting in crisp cuts without burs.

Applications:

- **Quickly cuts holes in materials up to 1" thick**

| | |
|------------------|-----------------|
| Thin Steel Plate | Iron |
| Aluminum | Copper |
| Cast Iron | Stainless Steel |
- **Cleanly cuts holes (9/16 up to 3" diameter) in:**

| | |
|-------------------|-----------------------|
| Junction Boxes | Switch Boxes |
| Metal Studs | Electrical Appliances |
| Lighting Fixtures | Pipe |

Ideal for auto, truck & body repair
- **Producing overlapping and uninterrupted holes easily.**

CARBIDE TIPPED HOLE CUTTERS CUTS 1" DEPTH

Includes Hole Saw, Arbor and Pilot Drill

| IBS No. | Shank | Cut | IBS No. | Shank | Cut |
|---------|-------|--------|---------|-------|---------|
| 19249 | 3/8" | 9/16 | 19265 | 3/8" | 1-9/16 |
| 19250 | 3/8" | 5/8 | 19266 | 3/8" | 1-5/8 |
| 19251 | 3/8" | 11/16 | 19267 | 3/8" | 1-11/16 |
| 19252 | 3/8" | 3/4 | 19268 | 3/8" | 1-3/4 |
| 19253 | 3/8" | 13/16 | 19269 | 3/8" | 1-13/16 |
| 19254 | 3/8" | 7/8 | 19270 | 3/8" | 1-7/8 |
| 19255 | 3/8" | 15/16 | 19271 | 3/8" | 1-15/16 |
| 19256 | 3/8" | 1 | 19272 | 3/8" | 2 |
| 19257 | 3/8" | 1-1/16 | 1927201 | 3/8" | 2-1/8 |
| 19258 | 3/8" | 1-1/8 | 1927202 | 3/8" | 2-1/4 |
| 19259 | 3/8" | 1-3/16 | 1927203 | 3/8" | 2-3/8 |
| 19260 | 3/8" | 1-1/4 | 1927204 | 3/8" | 2-1/2 |
| 19261 | 3/8" | 1-5/16 | 1927205 | 3/8" | 2-5/8 |
| 19262 | 3/8" | 1-3/8 | 1927206 | 3/8" | 2-3/4 |
| 19263 | 3/8" | 1-7/16 | 1927207 | 3/8" | 2-7/8 |
| 19264 | 3/8" | 1-1/2 | 1927208 | 1/2" | 3 |

HOLE CUTTER™ 1" Depth ACCESSORIES

| | |
|-------|---|
| 19273 | Pilot Drill |
| 19274 | Ejector Spring - 1" Depth |
| 19275 | Pilot Drill - Carbide Tipped for Ductile Pipe |

Cutter Extensions

- Extends the Carbide Tipped Hole Cutters by 4", giving access to hard-to-reach places.
- Made of precision machined tool steel for durability, stability and longer life.
- Only 2 extensions required to cover all sizes — less inventory means lower costs.



| IBS No. | Description |
|---------|---------------------------------|
| 192421 | 4" x 10mm Hole Cutter Extension |
| 192422 | 4" x 13mm Hole Cutter Extension |

T
A
P
S

B
U
R
S

B
L
A
D
E
S



IBS, INCORPORATED











Assortments Z02

5 Pc. Carbide Tipped Cutters

3/16" DEPTH

IBS No. 762R • 5 Items • 5 Pcs

Packaged in a Locking steel drawer for easy storage & organization









| | | | |
|---|---|---|---|
|  IBS, Inc. <small>SPECIALTY PRODUCTS FOR MAINTENANCE & REPAIR INDUSTRIALBOLT.COM © © © 800-678-1906</small> | | Carbide Tipped Cutters 3/16" Depth Assortment No. 762R | |
| 19205 7/8 CARBIDE TIPPED CUTTER - 3/16" DEPTH   | 19209 1-1/8 CARBIDE TIPPED CUTTER - 3/16" DEPTH   | 19213 1-3/8 CARBIDE TIPPED CUTTER - 3/16" DEPTH   | 19219 1-3/4 CARBIDE TIPPED CUTTER - 3/16" DEPTH   |
| 19223 2" CARBIDE TIPPED CUTTER - 3/16" DEPTH   | | | |

4 Pc. Carbide Tipped Cutters

1" DEPTH

IBS No. 763R • 4 Items • 4 Pcs

Packaged in a Locking steel drawer for easy storage & organization

| | | | |
|--|--|--|---|
|  IBS, Inc. <small>SPECIALTY PRODUCTS FOR MAINTENANCE & REPAIR INDUSTRIALBOLT.COM © © © 800-678-1906</small> | | Carbide Tipped Cutters 1" Depth Assortment No. 763R | |
| 19250 5/8 CARBIDE TIPPED CUTTER - 1" DEPTH   | 19252 3/4 CARBIDE TIPPED CUTTER - 1" DEPTH   | 19254 7/8 CARBIDE TIPPED CUTTER - 1" DEPTH   | 19256 1" CARBIDE TIPPED CUTTER - 1" DEPTH   |
| | | | |

T
A
P
S

B
U
R
S

B
L
A
D
E
S



5 Pc. Carbide Tipped Cutters

1" DEPTH

IBS No. 764R • 5 Items • 5 Pcs

Packaged in a locking steel drawer for easy storage & organization

Carbide Tipped Cutters
1" Depth

Assortment No. 764R

| | | | |
|---|---|---|---|
| <p>19254 7/8 CARBIDE TIPPED CUTTER - 1" DEPTH</p> | <p>19258 1-1/8 CARBIDE TIPPED CUTTER - 1" DEPTH</p> | <p>19262 1-3/8 CARBIDE TIPPED CUTTER - 1" DEPTH</p> | <p>19268 1-3/4 CARBIDE TIPPED CUTTER - 1" DEPTH</p> |
| <p>19272 2" CARBIDE TIPPED CUTTER - 1" DEPTH</p> | | | |

Carbide Tipped Cutter Sets (P28)



CARBIDE TIPPED CUTTER SET
3/16" Depth 5 Pcs

| IBS No. | Description |
|---------|--------------------------------|
| 19280 | 7/8, 1-1/8, 1-3/8, 1-3/4, & 2" |



CARBIDE TIPPED CUTTER SET
1" Depth 4 Pcs

| IBS No. | Description |
|---------|---------------------|
| 19281 | 5/8, 3/4, 7/8, & 1" |



CARBIDE TIPPED CUTTER SET
1" Depth 5 Pcs

| IBS No. | Description |
|---------|--------------------------------|
| 19283 | 7/8, 1-1/8, 1-3/8, 1-3/4, & 2" |

T
A
P
S

B
U
R
S

B
L
A
D
E
S



IBS, INCORPORATED

Miscellaneous Tools (T03)

T
A
P
S

B
U
R
S

B
L
A
D
E
S

Magnetic Drill Press

- The optimal drilling speed designed for use with carbide and HSS cutters on the toughest jobs and applications.
- Effective solution for drilling harder materials
- Powerful magnet for easier placement and better holding power on thinner material.
- Cost effective drill for running with Carbide cutters for longer life, higher cutting rate and capable of cutting harder materials.
- 1-3/8" maximum diameter annular cutter.
- 2" maximum drilling depth.
- 15.75" Height, 1100W, 11.5 Amp, 450-590 RPM.



| IBS No. | Description |
|---------|---------------------------------------|
| 19467 | Magnetic Drill Press up to 1-3/8 - 2" |
| 19456 | Arbor Adapter |
| 19457 | Drill Chuck |

Compact Magnetic Drill Press

Compact with Fixed Drill Motor for Work in Confined Spaces

- **Extremely compact** with ideal power to weight ratio for work at heights and in confined spaces.
- **Hand feed wheel mounts** on either side for use in special situations.
- **Die cast aluminum housing** for strength in the field.
- **Internal motor cable routing** prevents unintended threading or hanging up on the workpiece.
- Internal Cooling.
- **Easy** guide adjustment.
- **Stationary** drill motor.
- **Quill feed spindle** eliminates field maintenance and adjustments provides positive slug ejection.
- 1-5/8 maximum diameter annular cutter.
- 2" maximum drilling depth.



| IBS No. | Description |
|---------|---|
| 19468 | Compact Magnetic Drill Press for 1-3/8 - 2" |

Variable Speed / Reversible Magnetic Drill Press

Universal with 2 Speed Gearbox

For Use with 1-9/16 to 2" Annular Cutters

Compact with high functionality for universal use on the construction site and in the workshop.

- Simple and error-proof control concept in the operator's field of view.
- **Double drill motor guides** enable use of the largest core bits.
- **Reversible.**
- **Electronic speed control.**
- **High power motor** with stable speed.
- **High magnetic holding force.**
- Convenient magnetic holding force gauge.
- **Integrated cooling tank.**
- **Hand feed wheel** can be mounted on either side.



| IBS No. | Description |
|---------|--|
| 19469 | Variable Speed / Reversible Magnetic Drill Press |

Slugger Cutting Fluid for Mag Drills



- Water soluble concentrate makes up to 10 quarts of cutting fluid.
- Improves surface finish and reduces heat build up when drilling — extending the life of the cutter.
- Specially designed packaging with a sight window ensures proper mixing ratios.

| IBS No. | Description |
|---------|---|
| 19463 | Slugger Cutting Fluid for Mag Drills 1 Quart |
| 19464 | Slugger Cutting Fluid for Mag Drills 1 Gallon |



Ultra Lube Super Premium Cutting Fluid (S04)



Ultra Lube is a multi-purpose cutting fluid specially formulated to extend tool life and reduce chip welding. **Ultra Lube** also provides a precision finish with closer tolerances on finished work.

- **Super concentrated formula** will not run and even clings to vertical surfaces keeping the lubricant on the tool or at the or at the drilling/cutting point for continual lubrication resulting in cooler cutting which means longer tool life, saving time and money.
- **Contains no harsh chemicals or ozone depleting chemicals** which provides a virtual smoke free operation on even the most heat prone applications for a safer, cleaner cut making for faster clean up.
- **Available in a small, easier to handle 4 oz. bottle for hand drilling applications** that is easier to apply and get the lubricant exactly where it's needed, saving user time and money.
- **16 oz. bottle perfect for larger jobs** and coolant reservoir filling.

| IBS No. | Description |
|---------|--|
| 96050 | Ultra Lube Cutting Fluid 4 oz. bottle |
| 96070 | Ultra Lube Cutting Fluid 16 oz. bottle |

Rapid Core™ Ejecting Hole Saw Arbors



Our Rapid Core Ejecting Hole Saw Arbors make cutting holes a snap. This new design eliminates the need for a screwdriver or knife to dig out the core after drilling your hole. These arbors take efficiency to a whole new level.

- **Drop out the core** with the touch of the button.
- Saves time, money and eliminates the hassle of plug removal
- Delivers immediate and effortless plug removal
- Enlarge holes that are too small
- Extend pilot drill length to cut at an angle
- Durable high-speed pilot bits

Pilot Drill Bits

Rapid Core™ Ejecting Hole Saw Arbors



- Use with Rapid Core ejecting Holes Saw Arbors
- Smooth cuts even at slow speed
- Delivers immediate and effortless plug removal.

| IBS No. | Description | Qty |
|---------|--|-----|
| 29050 | Rapid Core Ejecting Arbor for 1-1/4" to 6" dia. Hole Saws 10mm (7/16") Hex Shank | 1 |
| 29051 | Rapid Core Ejecting Arbor for 9/16 to 1-3/16" dia. Hole Saws 8mm (5/16") Hex Shank | 1 |
| 29052 | Pilot Drill Bit for 29050 Hole Saw Arbor | 1 |
| 29053 | Pilot Drill Bit for 29051 Hole Saw Arbor | 1 |



IBS, INCORPORATED

Hole Saws & Cutters P28

T
A
P
S

B
U
R
S

B
L
A
D
E
S

Advanced Bi-Metal Hole Saws

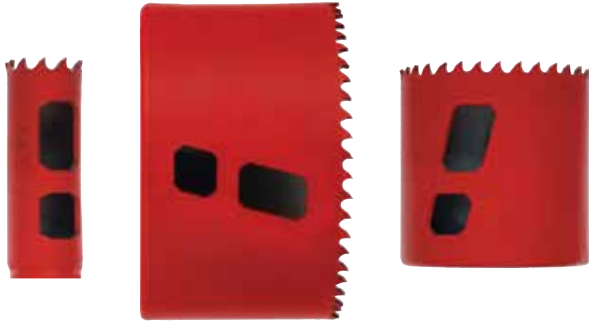

Our Bi-Metal Advanced Hole Saws feature new developments in tooth design and a new manufacturing process that outperforms the competition. All IBS mandrels are interchangeable with other name brands.

- **Patent pending tooth set is designed to remove material faster** providing smoother and faster cuts saving time and money.
- **Increased cutting depth of 1-15/16** means professional users can still cut through 2x4's in one pass and other thicker applications other hole saws require multiple cuts, saving time and money.
- **Wider cap design and thicker side wall** reduces runout, vibration and prevents collapsing.
- **Innovative angled side slots provide increased leverage** for faster and easier slug removal – saving time and money.
- **Premium M42 high speed steel cutting edge with 8% cobalt** results in twice the life of other hole saws for superior life and value.
- **Made in the USA**

Applications include: steel plate, pipe (round or square), angle iron, wood, composite materials and plastics.



ADVANCED BI-METAL HOLE SAWS

| IBS No. | Dia. | Arbor | IBS No. | Dia. | Arbor |
|---------|---------|-------|---------|--------|-------|
| 29200 | 9/16 | 29036 | 29226 | 2-5/16 | 29034 |
| 29201 | 5/8 | 29036 | 29227 | 2-3/8 | 29034 |
| 29203 | 3/4 | 29036 | 29228 | 2-1/2 | 29034 |
| 29204 | 13/16 | 29036 | 29229 | 2-9/16 | 29034 |
| 29205 | 7/8 | 29036 | 29230 | 2-5/8 | 29034 |
| 29206 | 15/16 | 29036 | 29231 | 2-3/4 | 29034 |
| 29207 | 1" | 29036 | 29232 | 2-7/8 | 29034 |
| 29208 | 1-1/16 | 29036 | 29233 | 3" | 29034 |
| 29209 | 1-1/8 | 29036 | 29234 | 3-1/8 | 29034 |
| 29210 | 1-3/16 | 29036 | 29235 | 3-1/4 | 29034 |
| 29211 | 1-1/4 | 29034 | 29236 | 3-3/8 | 29034 |
| 29212 | 1-5/16 | 29034 | 29237 | 3-1/2 | 29034 |
| 29213 | 1-3/8 | 29034 | 29238 | 3-5/8 | 29034 |
| 29214 | 1-7/16 | 29034 | 29239 | 3-3/4 | 29034 |
| 29215 | 1-1/2 | 29034 | 29240 | 3-7/8 | 29034 |
| 29216 | 1-9/16 | 29034 | 29241 | 4" | 29034 |
| 29217 | 1-5/8 | 29034 | 29242 | 4-1/8 | 29034 |
| 29218 | 1-11/16 | 29034 | 29243 | 4-1/4 | 29034 |
| 29219 | 1-3/4 | 29034 | 29245 | 4-1/2 | 29034 |
| 29220 | 1-13/16 | 29034 | 29246 | 4-3/4 | 29034 |
| 29221 | 1-7/8 | 29034 | 29247 | 5" | 29034 |
| 29222 | 2" | 29034 | 29248 | 5-1/2 | 29034 |
| 29223 | 2-1/16 | 29034 | 29249 | 6 | 29034 |
| 29224 | 2-1/8 | 29034 | | | |
| 29225 | 2-1/4 | 29034 | | | |



HOLE SAW ARBOR ADAPTER

| IBS No. | Description |
|---------|---|
| 29070 | Allows arbors with 1/2-20 thread to use saws with 5/8-18 thread. Use with 1-9/16" through 6" hole saws. |

HOLE SAW ARBORS

| IBS No. | Shank | Shape | Thread |
|---------|-------|-------|--------|
| 29034 | 7/16 | Hex | 5/8-18 |
| 29036 | 1/4 | Round | 1/2-20 |

HOLE SAW ARBOR PILOT DRILL

| IBS No. | Description |
|---------|----------------------------------|
| 29039 | Hole Saw Arbor Replacement Drill |



Advanced Bi-Metal Hole Saws 5/8" - 2" With Rapid Core Ejecting Arbor

IBS No. 782R • 14 Items • 14 Pcs

Packaged in a locking steel drawer for easy storage & organization

| | | | | | | | |
|-------------------------------------|---------------------------------------|---------------------------------------|--|---|--|--|--|
| | | | | Advanced Bi-Metal Hole Saws 5/8" to 2" with Rapid Core Ejecting Arbors Assortment No. 782R | | | |
| 29201 5/8 HOLE SAW ADVANCED EDGE | 29209 1-1/8 HOLE SAW ADVANCED EDGE | 29217 1-5/8 HOLE SAW ADVANCED EDGE | | 29050 RAPID CORE EJECTING ARBOR FOR 1-1/4 TO 6 HOLE SAWS | | | |
| 29203 3/4 HOLE SAW ADVANCED EDGE | 29211 1-1/4 HOLE SAW ADVANCED EDGE | 29219 1-3/4 HOLE SAW ADVANCED EDGE | | 29051 RAPID CORE EJECTING ARBOR FOR 9/16 - 1-3/16 DIAM HOLE SAWS | | | |
| 29205 7/8 HOLE SAW ADVANCED EDGE | 29213 1-3/8 HOLE SAW ADVANCED EDGE | 29222 2" HOLE SAW ADVANCED EDGE | | 29052 PILOT DRILL BIT FOR 29050 | | | |
| 29207 1" HOLE SAW ADVANCED EDGE | 29215 1-1/2 HOLE SAW ADVANCED EDGE | | | 29053 PILOT DRILL BIT FOR 29051 | | | |

Advanced Bi-Metal Hole Saws 2-1/8" - 4" With Rapid Core Ejecting Arbor

IBS No. 783R • 8 Items • 8 Pcs

Packaged in a locking steel drawer for easy storage & organization

| | | | | | | | |
|---------------------------------------|---------------------------------------|---------------------------------------|--|---|--|--|--|
| | | | | Advanced Bi-Metal Hole Saws 2-1/8" to 4" with Rapid Core Ejecting Arbors Assortment No. 783R | | | |
| 29224 2-1/8 HOLE SAW ADVANCED EDGE | 29228 2-1/2 HOLE SAW ADVANCED EDGE | 29237 3-1/2 HOLE SAW ADVANCED EDGE | | 29050 RAPID CORE EJECTING ARBOR FOR 1-1/4 TO 6 DIAM. HOLE SAWS | | | |
| 29225 2-1/4 HOLE SAW ADVANCED EDGE | 29233 3" HOLE SAW ADVANCED EDGE | 29241 4" HOLE SAW ADVANCED EDGE | | 29052 PILOT DRILL FOR 29050 | | | |

Advanced Bi-Metal Hole Saws 3/4" - 4" With Rapid Core Ejecting Arbor

IBS No. 784R • 18 Items • 18 Pcs

Packaged in a locking steel drawer for easy storage & organization

| | | | | | | | |
|---------------------------------------|---------------------------------------|---------------------------------------|--|---|--|--|--|
| | | | | Advanced Bi-Metal Hole Saws 3/4" to 4" with Rapid Core Ejecting Arbors Assortment No. 784R | | | |
| 29203 3/4 HOLE SAW ADVANCED EDGE | 29217 1-5/8 HOLE SAW ADVANCED EDGE | 29225 2-1/4 HOLE SAW ADVANCED EDGE | | 29241 4" HOLE SAW ADVANCED EDGE | | | |
| 29207 1" HOLE SAW ADVANCED EDGE | 29219 1-3/4 HOLE SAW ADVANCED EDGE | 29228 2-1/2 HOLE SAW ADVANCED EDGE | | 29050 RAPID CORE EJECTING ARBOR 1-1/4 - 6 DIAM HOLE SAW | | | |
| 29209 1-1/8 HOLE SAW ADVANCED EDGE | 29222 2" HOLE SAW ADVANCED EDGE | 29233 3" HOLE SAW ADVANCED EDGE | | 29051 RAPID CORE EJECTING ARBOR FOR 9/16 - 1-3/16 DIAM HOLE SAW | | | |
| 29211 1-1/4 HOLE SAW ADVANCED EDGE | 29224 2-1/8 HOLE SAW ADVANCED EDGE | | | 29052 PILOT DRILL FOR 29050 | | | |
| 29213 1-3/8 HOLE SAW ADVANCED EDGE | | 29237 3-1/2 HOLE SAW ADVANCED EDGE | | 29053 PILOT DRILL FOR 29051 | | | |
| 29215 1-1/2 HOLE SAW ADVANCED EDGE | | | | | | | |

TAPS BURRS BLADES



IBS, INCORPORATED

Assortments Z02

T
A
P
S

B
U
R
S

B
L
A
D
E
S

Advanced Bi-Metal Hole Saws 5/8" - 2"















IBS No. 729R • 14 Items • 14 Pcs

Packaged in a locking steel drawer for easy storage & organization



Advanced Bi-Metal Hole Saws 5/8" to 2"

Assortment No. 729R

| | | | |
|--|--|--|--|
| 29201 5/8 HOLE SAW ADVANCED EDGE  | 29209 1-1/8 HOLE SAW ADVANCED EDGE  | 29217 1-5/8 HOLE SAW ADVANCED EDGE  | 29036 LSS 4 H.S. ARBOR  |
| 29203 3/4 HOLE SAW ADVANCED EDGE  | 29211 1-1/4 HOLE SAW ADVANCED EDGE  | 29219 1-3/4 HOLE SAW ADVANCED EDGE  | 29034 LSS 2 H.S. ARBOR  |
| 29205 7/8 HOLE SAW ADVANCED EDGE  | 29213 1-3/8 HOLE SAW ADVANCED EDGE  | 29222 2" HOLE SAW ADVANCED EDGE  | 29039 1/4 PILOT DRILL  |
| 29207 1" HOLE SAW ADVANCED EDGE  | 29215 1-1/2 HOLE SAW ADVANCED EDGE  | | |

Advanced Bi-Metal Hole Saws 2-1/8" - 4"









IBS No. 730R • 8 Items • 8 Pcs

Packaged in a locking steel drawer for easy storage & organization



Advanced Bi-Metal Hole Saws 2-1/8" to 4"

Assortment No. 730R

| | | | |
|--|---|---|---|
| 29224 2-1/8 HOLE SAW ADVANCED EDGE  | 29228 2-1/2 HOLE SAW ADVANCED EDGE  | 29237 3-1/2 HOLE SAW ADVANCED EDGE  | 29034 LSS 2 H.S. ARBOR  |
| 29225 2-1/4 HOLE SAW ADVANCED EDGE  | 29233 3" HOLE SAW ADVANCED EDGE  | 29241 4" HOLE SAW ADVANCED EDGE  | 29039 1/4 PILOT DRILL  |

Advanced Bi-Metal Hole Saws 3/4" - 4"



















IBS No. 731R • 18 Items • 18 Pcs

Packaged in a locking steel drawer for easy storage & organization



Advanced Bi-Metal Hole Saws 3/4" to 4"

Assortment No. 731R

| | | | |
|--|--|--|--|
| 29203 3/4 HOLE SAW ADVANCED EDGE  | 29217 1-5/8 HOLE SAW ADVANCED EDGE  | 29225 2-1/4 HOLE SAW ADVANCED EDGE  | 29237 3-1/2 HOLE SAW ADVANCED EDGE  |
| 29207 1" HOLE SAW ADVANCED EDGE  | 29219 1-3/4 HOLE SAW ADVANCED EDGE  | 29228 2-1/2 HOLE SAW ADVANCED EDGE  | 29241 4" HOLE SAW ADVANCED EDGE  |
| 29209 1-1/8 HOLE SAW ADVANCED EDGE  | 29222 2" HOLE SAW ADVANCED EDGE  | 29233 3" HOLE SAW ADVANCED EDGE  | 29036 LSS 4 H.S. ARBOR  |
| 29211 1-1/4 HOLE SAW ADVANCED EDGE  | 29224 2-1/8 HOLE SAW ADVANCED EDGE  | | 29034 LSS 2 H.S. ARBOR  |
| 29213 1-3/8 HOLE SAW ADVANCED EDGE  | | | 29039 1/4 PILOT DRILL  |
| 29215 1-1/2 HOLE SAW ADVANCED EDGE  | | | |



Advanced Bi-Metal Hole Saws Industrial Kit

IBS No. 29282 • 15 Items • 15 Pcs (P28)
Packaged in a molded plastic case



| IBS No. | Description |
|---------|--|
| 29282 | Advanced Hole Saw Industrial Kit - 15 pcs Sizes: 3/4, 7/8, 1", 1-1/4, 1-3/8, 1-1/2, 1-3/4, 2, 2-1/4, 2-1/2", 3" plus 2 arbors & pilot drills and 1 ejector spring |

Advanced Bi-Metal Hole Saws Master Electricians Kit

IBS No. 29283 • 13 Items • 13 Pcs (P28)
Packaged in a metal case



| IBS No. | Description |
|---------|---|
| 29283 | Advanced Hole Saw Kit - Master Electrician 13 pcs Sizes: 7/8, 1-1/8, 1-3/8, 1-3/4, 2, 2-1/2, 3, 3-5/8, 4-1/8, 4-1/2" plus 3 arbors with pilot drills |

T
A
P
S

B
U
R
S

B
L
A
D
E
S



IBS, INCORPORATED

Hole Saws & Cutters P28

T
A
P
S

B
U
R
S

B
L
A
D
E
S

Hole Saw Recommended RPM Cutting Speeds

| Size (Inches) | Aluminum | Brass | Mild Steel | Cast Iron | Tool & Stainless Steel |
|---------------|----------|-------|------------|-----------|------------------------|
| 9/16 | 900 | 790 | 580 | 400 | 300 |
| 5/8 | 825 | 730 | 550 | 365 | 275 |
| 11/16 | 750 | 665 | 500 | 330 | 250 |
| 3/4 | 690 | 600 | 460 | 300 | 230 |
| 13/16 | 635 | 560 | 425 | 280 | 210 |
| 7/8 | 585 | 520 | 390 | 260 | 195 |
| 15/16 | 555 | 495 | 370 | 245 | 185 |
| 1 | 525 | 470 | 350 | 235 | 175 |
| 1-1/16 | 480 | 435 | 325 | 215 | 160 |
| 1-1/8 | 450 | 400 | 300 | 200 | 150 |
| 1-3/16 | 425 | 380 | 285 | 190 | 145 |
| 1-1/4 | 410 | 360 | 275 | 180 | 140 |
| 1-5/16 | 390 | 345 | 260 | 175 | 135 |
| 1-3/8 | 375 | 330 | 250 | 165 | 125 |
| 1-7/16 | 360 | 315 | 240 | 160 | 120 |
| 1-1/2 | 345 | 300 | 230 | 150 | 115 |
| 1-9/16 | 330 | 290 | 220 | 145 | 110 |
| 1-5/8 | 315 | 280 | 210 | 140 | 105 |
| 1-11/16 | 305 | 270 | 205 | 135 | 100 |
| 1-3/4 | 295 | 260 | 195 | 130 | 95 |
| 1-13/16 | 285 | 250 | 190 | 125 | 95 |
| 1-7/8 | 270 | 240 | 180 | 120 | 90 |
| 2 | 255 | 230 | 170 | 115 | 85 |
| 2-1/16 | 245 | 220 | 165 | 110 | 80 |
| 2-1/8 | 240 | 210 | 160 | 105 | 80 |
| 2-1/4 | 225 | 200 | 150 | 100 | 75 |
| 2-5/16 | 225 | 195 | 145 | 100 | 75 |
| 2-3/8 | 220 | 190 | 140 | 95 | 70 |
| 2-1/2 | 205 | 180 | 135 | 90 | 65 |
| 2-9/16 | 200 | 175 | 130 | 85 | 65 |
| 2-5/8 | 195 | 170 | 130 | 85 | 65 |
| 2-3/4 | 185 | 160 | 125 | 80 | 60 |
| 2-7/8 | 180 | 160 | 120 | 80 | 60 |
| 3 | 170 | 150 | 115 | 75 | 55 |
| 3-1/8 | 165 | 140 | 110 | 70 | 55 |
| 3-1/4 | 155 | 140 | 105 | 70 | 50 |
| 3-3/8 | 150 | 130 | 100 | 65 | 50 |
| 3-1/2 | 145 | 130 | 95 | 65 | 45 |
| 3-5/8 | 140 | 120 | 95 | 60 | 45 |
| 3-3/4 | 135 | 120 | 90 | 60 | 45 |
| 3-7/8 | 135 | 120 | 90 | 60 | 45 |
| 4 | 130 | 110 | 85 | 55 | 40 |
| 4-1/8 | 120 | 110 | 80 | 55 | 40 |
| 4-1/4 | 120 | 110 | 80 | 55 | 40 |
| 4-3/8 | 120 | 100 | 80 | 50 | 40 |
| 4-1/2 | 105 | 100 | 75 | 50 | 35 |

Note: When sawing ferrous metals, always use a cutting fluid to insure smooth operations and prolong saw life. (Do not use cutting fluids with cast iron.)



Heavy Duty 7-1/4 Blade Deck & Nail Circular Saw Blade

Designed with specially formulated carbide tips to ensure a long cutting life in pressure treated lumber, recycled lumber, decking and flooring with hidden or embedded nails. This blade also features a reinforced shoulder design, heat vents, expansion slots, and fits various 7-1/4" portable saws, including worm drives. This blade is very popular with contractors due to its rugged design and fast cutting ability.

Ideal for Pressure Treated Lumber, Hardy Board® and concrete coated lumber — this blade will even cut nails!

FEATURES:

- Thin Kerf for Fast Cuts
- Professional Grade Carbide Construction
- Reinforced Shoulder
- Aggressive Hook Angle
- Heat Vents for Cooler Operation
- Precision Ground Carbide Tips



| IBS No. | Description | Arbor | Grind |
|---------|-------------------------|-------|-------|
| 72518 | 7-1/4 X 18T Deck & Nail | 5/8 ◊ | ATB |

Steel & Ferrous Metal Circular Saw Blade

Designed with a durable C-6 carbide grade and triple chip tooth grind to ensure a long cutting life in ferrous metals, such as: steel studs, angle iron, pipe, rebar, channel, flat stock, conduit and much more. Can also be used for cutting non-ferrous metals, such as aluminum, copper, and brass. Specially formulated micro grain carbide tips with titanium and tantalum last longer and leave a burr free cut with little to no sparks or dust commonly associated with abrasives. This blade cuts 5 to 10 times faster and lasts up to 30 times longer than abrasives, allowing fewer blade changes and increased production.

FEATURES:

- Professional Grade C-6 Carbide Construction
- Precision Ground Carbide Tips
- Tensioned & Hardened Steel Plate
- Surface Ground Steel Plate
- Laser Cut Expansion Slots



| IBS No. | Description | Arbor | Carbide | Grind |
|---------|------------------------------------|-------|---------|-------|
| 72536 | 7-1/4 X 36T Steel & Ferrous Metals | 5/8 ◊ | C-6 | TCG |

Wood Cutting Circular Saw Blade

This wood cutting blade has been designed for quick, clean cutting with various portable saws, including worm drives. Ideal for cutting all types of hardwood, softwood, particle board and plywood. The aggressive hook angle and super thin kerf make for fast and easy cutting. Additional features include an anti-kickback tooth design for added safety, and heat vents for cooler operation, resulting in extended blade life. Long-lasting micro grain carbide tips are precision ground to ensure the best possible cut.

FEATURES:

- Super Thin Kerf for Fast Cuts
- Professional Grade C-2 Carbide
- Expansion Slots Prevent Warping
- Anti-Kickback Tooth Design
- Aggressive Hook Angle
- Heat Vents for Cooler Operation.
- Precision Ground Carbide Tips



| IBS No. | Description | Arbor | Carbide | Grind |
|---------|--------------------------|-------|---------|-------|
| 72524 | 7-1/4 X 24T Wood Cutting | 5/8 ◊ | C-3 | ATB |

Novelty Combo Blade

Designed for ripping and cross-cutting all types of hardwood, softwood, particle board and plywood with miter, chop, table and radial arm saws. The 4 & 1 tooth grind features for alternate top bevel teeth and 1 flat top raker with an anti-kickback tooth design. A large gullet space separates each tooth set and helps insure proper chip ejection. The special tooth configuration makes these blades great for both ripping and crosscutting applications.

FEATURES:

- Professional Grade C-4 Carbide Construction
- Precision Ground Carbide Tips
- Positive Hook Angle
- Tensioned and Hardened Steel Plate
- Anti-Kickback Raker Tooth
- Surface Ground Steel Plate



| IBS No. | Description | Arbor | Carbide | Grind |
|---------|-------------------------------|-------|---------|-------|
| 10028 | 10" X 50T Carbide Combo Blade | 5/8 | C-4 | 2 & 1 |

TAPS BURST BLADES



T
A
P
S
B
U
R
S
B
L
A
D
E
S

Miter Saw Rip Blade

Designed for ripping all types of hardwood, softwood, and plywood with table and radial arm saw. Features precision ground micro grain carbide tips and copper plugged expansion slots for less noise and vibration. Also features an anti-kickback tooth design, aggressive hook angle, and large gullets, making it great for fast ripping applications.

FEATURES:

- Professional Grade C-4 Carbide Construction
- Copper Plugged Expansion Slots
- Aggressive Hook Angle
- Anti-Kickback Tooth Design
- Precision Ground Carbide Tips
- Tensioned & Hardened Steel Plate Construction
- Surface Ground Steel Plate



| IBS No. | Description | Arbor | Carbide | Grind |
|---------|---------------------------------|-------|---------|-------|
| 100210 | 10" X 24T Carbide Ripping Blade | 5/8 | C-4 | ATB |

Miter Saw Blade

This fine-finishing blade has been designed for the cleanest crosscutting of all types of hardwood and soft wood with miter, chop, table and radial arm saws. Features precision ground micro grain carbide tips, for less noise and vibration. Great for cross-cutting applications where a very smooth cut is needed.

FEATURES:

- Professional Grade C-4 Carbide Construction
- Copper Plugged Expansion Slots
- Positive Hook Angle
- Precision Ground Carbide Tips
- Tensioned & Hardened Steel Plate Construction
- Surface Ground Steel Plate



| IBS No. | Description | Arbor | Carbide | Grind |
|---------|------------------------------------|-------|---------|-------|
| 100230 | 10" X 80T Carbide Smooth Cut Blade | 5/8 | C-4 | ATB |

Slugger Carbide-Tipped Circular & Chop Saw Blades

For Use with Metal Cutting Circular and Chop Saws Only

Slugger™ industrial quality metal cutting saw blades are the finest blades available for the professional fabricator and metal worker.

- Tungsten Carbide Construction — provides exceptional wear resistance and maximum cutting life.
- Clean cutting — leaves a bur-free cut ready for use or welding. No additional grinding necessary.
- Cool Cutting—unique metallurgy of the carbide tips result in minimum heat transferred to the inner plate. Most of the heat remains with the chips collected in the unique chip collector.
- High Performance — Blades cut much faster than traditional methods saving time, labor and money.

Blades are available for clean and cool cutting of mild steel, stainless steel, and aluminum.



7-1/4" INDUSTRIAL METAL CUTTING CIRCULAR SAW BLADES - CARBIDE TIPPED

| IBS No. | Blade Dia. | Teeth | Arbor | RPM | Applications |
|---------|------------|-------|-------|------|--|
| 137756 | 7.25" | 36T | 20mm | 3500 | Circular Saw Blades for Steel |
| 137757 | 7.25" | 54T | 20mm | 3500 | Circular Saw Blades for Aluminum |
| 137758 | 7.25" | 48T | 20mm | 3500 | Circular Saw Blade for Stainless Steel |

14" INDUSTRIAL METAL CUTTING CHOP SAW BLADES - CARBIDE TIPPED

| IBS No. | Blade Dia. | Teeth | Arbor | RPM | Applications |
|---------|------------|-------|-------|------|------------------------------------|
| 137761 | 14.0" | 66T | 1.0" | 1450 | Chop Saw Blades for Steel |
| 137762 | 14.0" | 80T | 1.0" | 1450 | Chop Saw Blades for Aluminum |
| 137763 | 14.0" | 90T | 1.0" | 1450 | Chop Saw Blade for Stainless Steel |

T
A
P
S

B
U
R
S

B
L
A
D
E
S



IBS, INCORPORATED

Circular Saw Blades P11

Circular Saws (T03)

- Increase Productivity — No milling or deburring with near surgical dry-cut technology.
- Cuts a variety of Metals, Plastic and Wood.
- Cool to the Touch — No waiting for your workpiece to cool down.
- Precise Cutting — with integrated laser sighting system (7-1/4" saw only).



Circular & Chop Saw Blades Sold Separately

7-1/4" CIRCULAR SAW

| SPECIFICATIONS | 7-1/4" |
|-------------------|---|
| Part Number | 137759 |
| Cutting Capacity | 2-1/4" |
| Weight | 15 lbs. |
| Blade Diameter | 7.25" |
| Arbor | 3/4" (20mm) |
| RPM | 3800 |
| Beveling/Mitering | Beveling / 45° |
| Motor | 120V / 1400W |
| Depth Adjustment | Yes |
| Chip Cover | 1 Cover for Metal |
| Applications | Pipe, plate, channel, grating, roof decking, silos, emergency rescue. |

- Powerful double-insulated motor for continuous loads
- Internally powered laser (no batteries required)
- Spring loaded lower guard
- Integrated chip collection
- Soft Start
- Electric Brake
- Smooth bevel and angle cutting adjustments
- Well balanced handle design for better control

INCLUDES: 1 tool case, 1 blade, 1 wrench, 1 guide plate, 1 safety eyewear, 1 ear protection, 1 instruction manual

DO NOT USE on materials thicker than 3/8" solid for aluminum, 5/16" for mild steel, or 1/4" for solid stainless steel.

14" CIRCULAR SAW

| SPECIFICATIONS | 14" |
|-------------------|---|
| Part Number | 137760 |
| Cutting Capacity | 4-3/4" |
| Weight | 54 lbs. |
| Blade Diameter | 14" |
| Arbor | 1" (25.4mm) |
| RPM | 1300 |
| Beveling/Mitering | Mitering / 45° |
| Motor | 120V / 1800 W |
| Depth Adjustment | Two Position Vise |
| Chip Cover | Chip Tray |
| Applications | Pipe, plate, channel, conduit angle iron, metal studs, rebar, tubing, etc.. |

- Low speed high torque motor
- High Precision durable steel construction
- Cast aluminum base
- Quick release table/base clamp cuts 0o to 45o
- Smooth bevel and angle cutting adjustments
- Eye protection plate
- Table/base clamp with quick release
- Depth stop
- Well balanced handle design for better control
- Integrated chip collection

INCLUDES: 1 tool case, 1 blade, 1 wrench, 1 guide plate, 1 safety eyewear, 1 ear protection, 1 instruction manual

DO NOT USE on materials thicker than 3/8" solid for aluminum, 5/16" for mild steel, or 1/4" for solid stainless steel.

T
A
P
S

B
U
R
S

B
L
A
D
E
S



General Information

- Bandsaw Blades are custom ordered to your specifications
- Allow up to 3 weeks for delivery
- All bandsaw blades are non-stock, & NON-RETURNABLE
- To order, specify the following:

1. Composition / Material: Bi-Metal or Carbon

Bi-Metal:

Bi-Metal blades are designed to cut just about anything that can be cut.

Bi-Metal blades have hardened High Speed Steel teeth that are electron beam welded to a high strength spring steel alloy backing material. The result is a durable, fatigue resistant blade that should last many times longer than carbon blades because it is able to withstand the heat when cutting steel and other alloys.



Bi-Metal blades have a variable tooth pitch which means that the blade simultaneously cut and clean to reduce friction and vibration for faster, smoother and straighter cutting.

Cutting Applications: Used on most metal working applications, carbon steel, stainless steel and ferrous metal, non-ferrous metal, alloy and tool steel, nickel brass alloy, wood, plastic, foam, titanium and just about anything that needs to be cut.

Carbon: (2 designs)

Carbon blades are mainly for non-ferrous metal, wood, plastic, and other materials.

1. Blades with 10 tpi and 1/2" width or larger are Carbon Hard Back.

Carbon Hard Back blades are constructed from one piece of carbon steel, with spring tempered back and tooth hardness of RC 04-07. The backing material resists snagging and scoring of the band and accepts heavier food pressure and back tension than flex back, for faster, straighter cutting.

Cutting Applications: Used on wood, plastics, abrasive materials, carbon tool steels, solid structural steel, brass bronze, cast iron lead, zinc, cold rolled steel. Small to mid-sized machines.



2. Blades with 8 tpi and under 1/2" are Carbon Flex Back.

Carbon Flex Back blades are constructed from one piece of carbon steel with spring tempered back and tooth hardness of RC04-07, and back hardness of RC28-30. Excellent fatigue resistance, even at high band speeds.

Cutting Applications: Used on wood, plastics, fiberglass, mild steels, cast iron copper, lead, & aluminum. Use light duty saws with band speeds below 4,000 min.



2. Teeth Per Inch (TPI) refer to price pages

BI-METAL — VARI-PITCH TOOTH

CARBON — STRAIGHT TOOTH

| BI-METAL — VARI-PITCH TOOTH | | CARBON — STRAIGHT TOOTH | |
|-----------------------------|-------|-------------------------|----------|
| Dia./ Wall / Thickness | TPI | Dia./ Wall / Thickness | TPI |
| Up to 3/16" | 14/16 | 1/16" to 1/8" | 24 |
| 3/16" to 3/8" | 10/14 | Up to 1/8" | 18 |
| 1/4" to 1/2" | 8/12 | 1/8" to 1/4" | 14 |
| 1/2" to 1" | 6/10 | 1/4" to 1/2" | 10 |
| 1" to 1-1/2" | 5/8 | 1/2" to 1" | 8 |
| 1-1/2" to 3" | 4/5 | 1" to 3" | 5 |
| 3" to 5" | 3/4 | 3" to 5" | 4 |
| 5" to 8" | 2/3 | 5" to 8" | 3 |
| 8" or larger | 1/2 | 8" or larger | Z — 1.25 |

3. Length — Refer to chart located in price pages

4. Width — Refer to chart located in price pages

T
A
P
S

B
U
R
S

B
L
A
D
E
S



Anatomy of a Bandsaw Blade

Although it looks like a flat piece of metal with teeth, a quality industrial band saw blade is actually a sophisticated cutting tool. Its ability to effectively cut through tough metals, composite materials, plastics, and woods depends on a variety of interrelated factors such as the design, spacing and set of the teeth; the design and capacity of the gullets to make sure chips are effectively removed; the composition of the backer strip; and the gage of the metal. These consideration must be taken into account when selecting the right blade for your application.

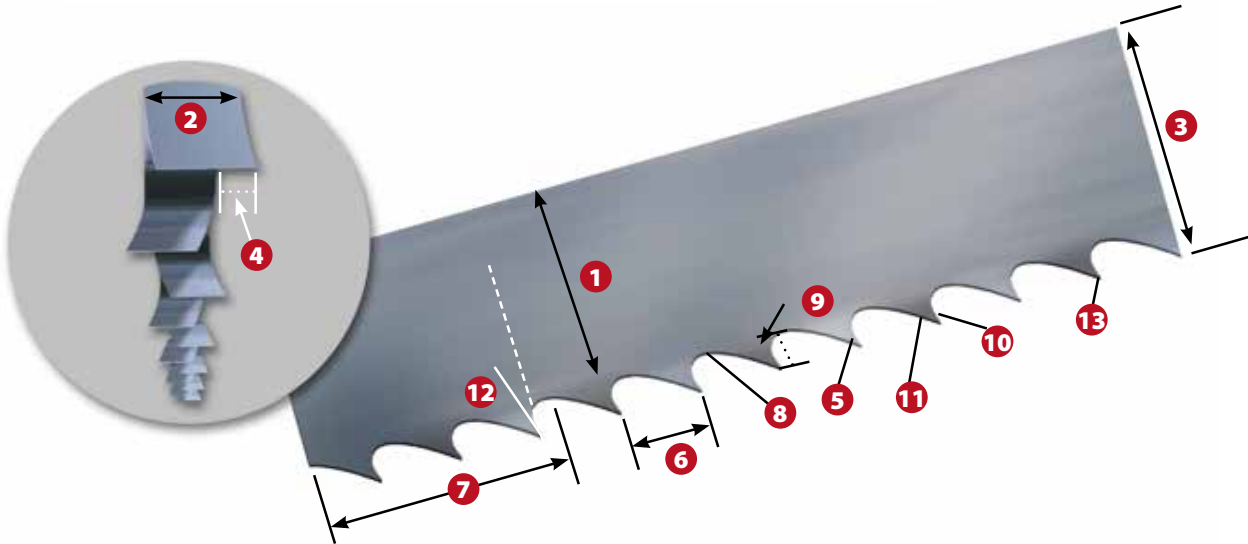

- 1 Blade Back ----- The body of the blade not including tooth portion
- 2 Gage ----- The thickness of the blade
- 3 Width ----- The tip of tooth to back of blade
- 4 Set ----- The bending of the teeth right or left
- 5 Tooth ----- The cutting portion of the saw blade
- 6 Teeth Pitch ----- The distance from one tooth tip to the next
- 7 T.P.I. ----- The number of teeth per inch measured gullet to gullet
- 8 Gullet ----- The curved area between the tooth points
- 9 Gullet Depth ----- The distance from the tooth tip to the bottom of the gullet
- 10 Tooth Face ----- The surface of the tooth on which the chip is formed
- 11 Tooth Flank ----- The angled back surface of the tooth opposite the tooth face
- 12 Tooth Rake Angle -- The angle of the tooth face measured with respect to a line perpendicular to the cutting direction of the saw
- 13 Tooth Tip ----- The cutting edge of the saw tooth



Tooth Selection Guide (teeth per inch)

| Material Size (Inches) | Teeth Per Inch | Material Size (Metric) | Wall Thickness (Inches) | Teeth Per Inch | Wall Thickness (Metric) |
|------------------------|----------------|------------------------|-------------------------|----------------|-------------------------|
| 0 | | 0 | 1/16 | 10/14 | - 1.8 |
| .1 | 14/18 | 2.5 | 1/8 | 8/12 | - 3.2 |
| .2 | 10/14 | 5.1 | 3/16 | 6/10 | - 4.8 |
| .3 | 8/12 | 7.6 | 1/4 | 5/8 | - 6.3 |
| .4 | 8/12 | 10.2 | 5/16 | 5/8 | - 7.9 |
| .5 | 6/10 | 12.7 | 3/8 | 4/6 | - 9.5 |
| .6 | 6/10 | 15.0 | 7/16 | 4/6 | - 11.0 |
| .7 | 5/8 | 17.8 | 1/2 | 4/6 | - 12.7 |
| .8 | 5/8 | 20.0 | 9/16 | 4/6 | - 14.3 |
| .9 | 5/8 | 22.9 | 5/8 | 3/4 | - 15.8 |
| 1 | 5/8 | 25.4 | 11/16 | 3/4 | - 17.5 |
| 1-1/4 | 4/6 | 31.8 | 3/4 | 3/4 | - 19.0 |
| 1-1/2 | 4/6 | 38.1 | 13/16 | 3/4 | - 20.6 |
| 1-3/4 | 4/6 | 44.5 | 7/8 | 3/4 | - 22.0 |
| 2 | 4/6 | 50.8 | 15/16 | 2/3 | - 23.8 |
| 2-1/4 | 3/4 | 57.2 | 1 | 2/3 | - 25.4 |
| 2-1/2 | 3/4 | 63.5 | 1-1/8 | 2/3 | - 28.6 |
| 2-3/4 | 3/4 | 69.9 | 1-1/4 | 2/3 | - 32.0 |
| 3 | 3/4 | 76.2 | 1-3/8 | 2/3 | - 35.0 |
| 3-1/4 | 3/4 | 82.6 | 1-1/2 | 2/3 | - 38.0 |
| 3-1/2 | 3/4 | 88.9 | | | |
| 3-3/4 | 3/4 | 95.3 | | | |
| 4 | 3/4 | 101.6 | | | |
| 5 | 2/3 | 127.0 | | | |
| 6 | 2/3 | 152.4 | | | |
| 7 | 2/3 | 177.8 | | | |
| 8 | 2/3 | 203.0 | | | |
| 9 | 1.4/2.5 | 228.6 | | | |
| 10 | 1.4/2.5 | 254.0 | | | |
| 15 | 1/1.5 | 381.0 | | | |
| 30 | 1/1.5 | 762 | | | |

 **Rectangular Solids:**
(Use Width)

 **Round Solids:**
(Use Diameter)



Pipe Tubing Structurals
(Use Wall Thickness)

Cutting speed - structurals rule of thumb:

When cutting structurals use a cutting speed of
250-325 S.F.M. Wet • 200-250 S.F.M. Dry

T
A
P
S





B
U
R
S

B
L
A
D
E
S



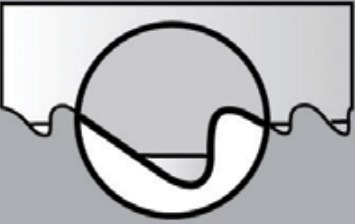
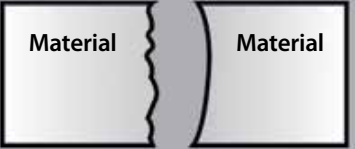



Bandsaw Blade Problem Solving

T
A
P
S
B
U
R
S
B
L
A
D
E
S

| Problem | Problem Cause | Solution |
|--|--|--|
|  <p>Premature Blade Breakage Straight Break indicates fatigue</p> | <ul style="list-style-type: none"> • Incorrect blade - teeth too coarse • Blade tension too high • Side guides too tight • Damaged or misadjusted blade guides • Excessive feed • Incorrect cutting fluid • Wheel diameter too small for blade • Blade rubbing on wheel flanges • Teeth in contact with work before starting saw • Incorrect blade speed | <ul style="list-style-type: none"> • Use finer tooth pitch • Reduce blade tension (see machine manual) • Check side guide clearance (see machine manual) • Check all guides for alignment/damage • Reduce feed pressure • Check coolant • Use thinner blade • Adjust wheel alignment • Allow 1/2" clearance before starting cut • Increase or decrease blade speed |
|  <p>Premature Dulling of Teeth</p> | <ul style="list-style-type: none"> • Teeth pointing in wrong direction / blade mounted backwards • Improper or no blade break-in • Hard spots in material • Material work hardened • Improper coolant • Improper coolant concentration • Speed too high • Feed too light • Teeth too small | <ul style="list-style-type: none"> • Install blade correctly. If teeth are facing the wrong direction, flip blade inside out • Break in blade properly (Page 17) • Check for hardness or hard spots like scale or flame cut areas • Increase feed pressure • Check coolant type • Check coolant mixture • Check recommended blade speed (Page 24-25) • Increase feed pressure • Increase tooth size |
|  <p>Inaccurate Cut</p> | <ul style="list-style-type: none"> • Tooth set damage • Excessive feed pressure • Improper tooth size • Cutting fluid not applied evenly • Guides worn or loose • Insufficient blade tension | <ul style="list-style-type: none"> • Check for worn set on one side of blade • Reduce feed pressure • Check tooth size chart (Page 23) • Check coolant nozzles • Tighten or replace guides, check for proper alignment • Adjust to recommended tension |
|  <p>Band Leading in Cut</p> | <ul style="list-style-type: none"> • Over-feed • Insufficient blade tension • Tooth set damage • Guide arms loose or set too far apart • Chips not being cleaned from gullets • Teeth too small | <ul style="list-style-type: none"> • Reduce feed force • Adjust recommended tension • Check material for hard inclusions • Position arms as close to work as possible. Tighten arms. • Check chip brush • Increase tooth size |
|  <p>Chip Welding</p> | <ul style="list-style-type: none"> • Insufficient coolant flow • Wrong coolant concentration • Excessive speed and/or pressure • Tooth size too small • Chip brush not working | <ul style="list-style-type: none"> • Check coolant level and flow • Check coolant ratio • Reduce speed and/or pressure • Use coarser tooth pitch • Repair or replace chip brush |
|  <p>Teeth Fracture Back of tooth indicates work spinning in clamps</p> | <ul style="list-style-type: none"> • Incorrect speed and/or feed • Incorrect blade pitch • Saw guides not adjusted properly • Chip brush not working • Work spinning or moving in vise | <ul style="list-style-type: none"> • Check cutting chart (Page 24-25) • Check tooth size chart (Page 23) • Adjust or replace saw guides • Repair or replace chip brush • Check bundle configuration/adjust vise pressure |
|  <p>Irregular Break Indicates material movement</p> | <ul style="list-style-type: none"> • Indexing out of sequence • Material loose in vise | <ul style="list-style-type: none"> • Check proper machine movement • Check vise or clamp |

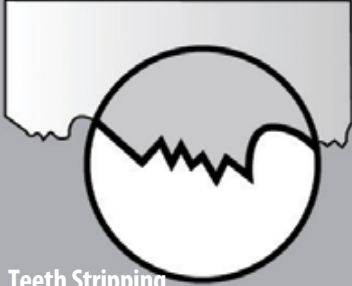
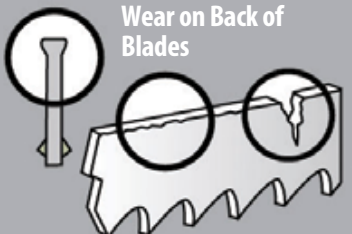

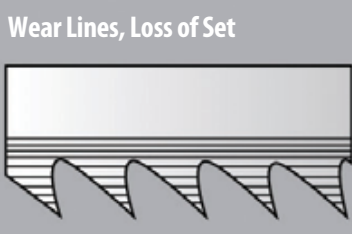
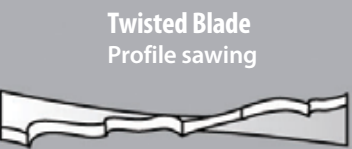
Bandsaw Blade Problem Solving

| Problem | Problem Cause | Solution |
|---|---|--|
|  <p>Teeth Stripping</p> | <ul style="list-style-type: none"> • Feed pressure too high • Tooth stuck in cut • Improper or insufficient coolant • Incorrect tooth size • Hard spots in material • Work spinning in vise - loose nest or bundle • Blade speed too slow • Blade teeth running backwards • Chip brush not working | <ul style="list-style-type: none"> • Reduce feed pressure • Do not enter old cut with a new blade • Check coolant flow and concentration • Check tooth size chart (Page 23) • Check material for hard inclusions • Check clamping pressure - be sure work is held firmly • Increase blade speed - see cutting chart (Page 24-25) • Reverse blade (turn inside out) • Repair or replace chip brush |
|  <p>Wear on Back of Blades</p> | <ul style="list-style-type: none"> • Excessive feed pressure • Insufficient blade tension • Back-up guide roll frozen, damaged, or worn • Blade rubbing on wheel flange | <ul style="list-style-type: none"> • Decrease feed pressure • Increase blade tension and readjust guides • Repair or replace back-up roll or guide • Adjust wheel cant |
|  <p>Rough Cut Washboard surface Vibration and or chatter</p> | <ul style="list-style-type: none"> • Dull or damaged blade • Incorrect speed or feed • Insufficient blade support • Incorrect tooth pitch • Insufficient coolant | <ul style="list-style-type: none"> • Replace with new blade • Increase speed or decrease feed • Move guide arms as close as possible to the work • Use finer pitch blade • Check coolant flow |
|  <p>Wear Lines, Loss of Set</p> | <ul style="list-style-type: none"> • Saw guide inserts or wheel flange are riding on teeth • Insufficient blade tension • Hard spots in material • Back-up guide worn | <ul style="list-style-type: none"> • Check machine manual for correct blade width • Tension blade properly • Check material for inclusions • Replace guide |
|  <p>Twisted Blade Profile Profile sawing</p> | <ul style="list-style-type: none"> • Blade binding in cut • Side guides too tight • Radius too small for blade width • Work not firmly held • Erratic coolant flow • Excessive blade tension | <ul style="list-style-type: none"> • Decrease feed pressure • Adjust side guide gap • Use narrower blade • Check clamping pressure • Check coolant nozzles • Decrease blade tension |
|  <p>Blade Wear Teeth blued</p> | <ul style="list-style-type: none"> • Incorrect blade • Incorrect feed or speed • Improper or insufficient coolant | <ul style="list-style-type: none"> • Use coarser tooth pitch • Increase feed or decrease speed • Check coolant flow |

T
A
P
S

B
U
R
S

B
L
A
D
E
S



IBS, INCORPORATED

Bandsaw Blades P11

Bi-Metal Portable Bandsaw Blades — Standard Pitch



BI-METAL PORTABLE BANDSAW BLADES

With sharp cutting edges and straight pitch teeth, these blades cut fast and last a long time with reduced breakage

| IBS No. | Length | | TPI | Application | Thicknesses |
|---------------|---------------------|-------------------|-------|--------------|----------------|
| | inches | mm | | | |
| 447810 | 44-7/8 X 1/2 X .020 | 1140 X 12.7 X .50 | 10/14 | Thick Metal | 1/2" + Thicker |
| 447814 | 44-7/8 X 1/2 X .020 | 1140 X 12.7 X .50 | 12/16 | Medium Metal | 3/8" - 1/2" |
| 447818 | 44-7/8 X 1/2 X .020 | 1140 X 12.7 X .50 | 14/18 | Medium Metal | 1/4" - 3/8" |
| 447824 | 44-7/8 X 1/2 X .020 | 1140 X 12.7 X .50 | 24 | Thin Metal | 3/16 + Thinner |

Use on machine metals, including stainless steel, pipe, tubing and solids. Premium straight pitch blades offer high resistance to heat, wear and shock, contributing to longer blade life.

T
A
P
S

B
U
R
S

B
L
A
D
E
S

IBS, INCORPORATED

Hacksaw / Reciprocating Saw Blades P11



4-in-1 Hacksaw Frame

IBS No. 16411

The Nicholson® Pro Series 4-in-1 Hacksaw takes versatility and quality to an entirely new level. Its frame is designed to hold blades at a tension of up to 30,000 psi, for smooth and straight cuts, whether in standard, 45° angle, or low profile configurations. And while some other hacksaws have jab saw capability, the unique design of the Nicholson Pro Series accommodates a heavy duty reciprocal saw blade for maximum performance in jab saw applications.



GENERAL USE

Standard 90° blade position is best for most jobs around the shop



45° ANGLE

The 45° blade position allows flush cuts and use in obstructed applications



LOW PROFILE

Low profile configuration allows quality high tension cuts in tight spaces.



JAB SAW

Heavy duty Jab Saw configuration is perfect for many close-in applications.

Four Ways to Get the Job Done!



T
A
P
S

B
U
R
S

B
L
A
D
E
S



T
A
P
S
B
U
R
S
B
L
A
D
E
S

IBS Hi-Alloy Hacksaw Blades

The IBS Hi-Alloy hand hacksaw blade is the ideal combination of high, red heat hardness on the cutting edge, joined to a tough, alloy steel back with great strength and stretch resistance.

This combination, made possible by **electron beam welding**, gives performance never before attainable in any hand hacksaw blade.

The **bi-metal design** creates a shatter resistant blade with the ability to cut faster and longer because it stays sharper.

The best blade possible for cutting materials including stainless steel hardened alloys or ANYTHING that can be cut.

Manufactured in varied pitch, which means that the blade simultaneously cuts and cleans for low friction and fast cutting.

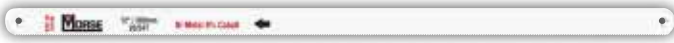

FINE COARSE FINE COARSE

| IBS No. | Size | TPI | Qty |
|---------|-----------|-----------|-----|
| 16395 | 12" x 1/2 | 18/14 tpi | 10 |
| 16396 | 12" x 1/2 | 24 tpi | 10 |
| 16398 | 12" x 1/2 | 32/26 tpi | 10 |



IBS Hi-Alloy & Triple-Cut Hacksaw Blades

IBS No. 785R • 4 Items • 20 Pcs

Packaged in a locking steel drawer for easy storage & organization

|  IBS, Inc. SPECIALTY PRODUCTS FOR MAINTENANCE & REPAIR INDUSTRIALBOLT.COM © © © 800-678-1906 | | Hi-Alloy Bi-Metal Hacksaw Blades | |
|--|--|---|--|
| Assortment No. 785R | | | |
| 16395 12 18/14 HI-ALLOY HACKSAW BLADE |  |  | |
| 16396 12 24/20 HI-ALLOY HACKSAW BLADE |  |  | |
| 16398 12 32/26 HI-ALLOY HACKSAW BLADE |  |  | |
| 16399 12 18/24/32 TRIPLE CUT BIMETAL HACKSAW BLADE |  |  | |
| | | | |
| | | | |

T
A
P
S

B
U
R
S

B
L
A
D
E
S



IBS, INCORPORATED

Reciprocating Saw Blades (P11)

Advanced Edge Power Reciprocating Saw Blades



The Advanced Edge Power reciprocating saw blade powers through the toughest applications. This heavy duty blade is perfect for cutting any machineable metal as well as wood, wood composite, plastic or rubber.

- **1" width** for more rigidity and beam strength.
- **.042" thickness** accepts heavier feed pressure.
- **Straight tooth pitch** gives a smooth cutting action.
- **Bi-Metal construction** for long cutting life and heat and wear resistance.
- **MADE IN THE USA!**







| IBS No. | Description | PKG |
|---------|-------------|-----|
| 470610 | 6IN 10TPI | 2 |
| 470910 | 9IN 10TPI | 2 |
| 471210 | 12IN 10TPI | 2 |
| 470614 | 6IN 14TPI | 2 |
| 470914 | 9IN 14TPI | 2 |
| 471214 | 12IN 14TPI | 2 |
| 470618 | 6IN 18TPI | 2 |
| 470918 | 9IN 18TPI | 2 |
| 471218 | 12IN 18TPI | 2 |



Advanced Edge Power Reciprocating Saw Blades with Tool Ease Lubricant Stick

IBS No. 840R 10 Items • 21 Pcs

Packaged in a locking steel drawer for easy storage & organization

| IBS, Inc. SPECIALTY PRODUCTS FOR MAINTENANCE & REPAIR INDUSTRIALBOLT.COM © © © 500-678-1906 | | Advanced Edge Power Reciprocating Saw Blades | |
|---|--|---|---|
| Assortment No. 840R | | | |
| 470610 6IN X .042 10TPI ADVANDED EDGE POWER RECIP BLADE 1IN WIDTH | 470910 9IN X .042 10TPI ADVANDED EDGE POWER RECIP BLADE 1IN WIDTH |  | |
| 471210 12IN X .042 10TPI ADVANDED EDGE POWER RECIP BLADE 1IN WIDTH | |  | |
| 470614 6IN X .042 14TPI ADVANDED EDGE POWER RECIP BLADE 1IN WIDTH | 470914 9IN X .042 14TPI ADVANDED EDGE POWER RECIP BLADE 1IN WIDTH |  | |
| 471214 12IN X .042 14TPI ADVANDED EDGE POWER RECIP BLADE 1IN WIDTH | |  | |
| 470618 6IN X .042 18TPI ADVANDED EDGE POWER RECIP BLADE 1IN WIDTH | 470918 9IN X .042 18TPI ADVANDED EDGE POWER RECIP BLADE 1IN WIDTH |  | |
| 471218 12IN X .042 18TPI ADVANDED EDGE POWER RECIP BLADE 1IN WIDTH | | 74172 TOOL EASE |  |

T
A
P
S
B
U
R
S
B
L
A
D
E
S

IBS, INCORPORATED

Hacksaw / Reciprocating Saw Blades P11



Bi-Metal Reciprocating Saw Blade

IBS Reciprocating Saw Blades are designed to fit all popular machines that take 1/2" shank. Bi-Metal blades consist of a high-speed cutting edge welded to a flexible alloy steel back. Faster cutting with sharper, harder teeth and extra-strength shank. Bi-metal blades reduce breakage and last longer than conventional carbon and all high-speed blades. Recommended for cutting steel, stainless steel, nail-embedded wood, hardwood flooring, reinforcing bar, cast iron and pipe.



Plaster with metal lathe plaster board, sheet rock, plaster walls. Tooth design cuts both forward and on backward stroke.

| IBS No. | Size | TPI | Qty |
|---------|-----------------|-------|-----|
| 44656 | 6" x 3/4 x .035 | 6 tpi | 5 |



Wood, nail-embedded wood, compositions plastic, cast aluminum, light gauge metals.

| IBS No. | Size | TPI | Qty |
|---------|-----------------|--------|-----|
| 44610 | 6" x 3/4 x .035 | 10 tpi | 5 |



All woods, plastic, cast aluminum, soil pipe, nail-embedded wood.

| IBS No. | Size | TPI | Qty |
|---------|-----------------|-----------|-----|
| 4461014 | 6" x 3/4 x .050 | 10/14 tpi | 5 |
| 4481014 | 8" x 3/4 x .050 | 10/14 tpi | 5 |



Wood, nail-embedded wood, compositions plastic, cast aluminum, light gauge metals.

| IBS No. | Size | TPI | Qty |
|---------|------------------|-------|-----|
| 44606 | 6" x 3/4 x .050 | 6 tpi | 5 |
| 44906 | 9" x 3/4 x .050 | 6 tpi | 5 |
| 441206 | 12" x 3/4 x .050 | 6 tpi | 5 |



Heavy gauge metals of 18 gauge to 1/8" thick conduit, pipe, channels and tubing.

| IBS No. | Size | TPI | Qty |
|---------|------------------|--------|-----|
| 44618 | 6" x 3/4 x .035 | 18 tpi | 5 |
| 44818 | 8" x 3/4 x .035 | 18 tpi | 5 |
| 44918 | 9" x 3/4 x .035 | 18 tpi | 5 |
| 441218 | 12" x 3/4 x .035 | 18 tpi | 5 |
| 44914 | 9" x 3/4 x .035 | 14 tpi | 5 |



Heavy gauge metals 1/8" thick and above. Barstock and angles.

| IBS No. | Size | TPI | Qty |
|---------|-----------------|--------|-----|
| 44614 | 6" x 3/4 x .035 | 14 tpi | 5 |

T
A
P
S

B
U
R
S

B
L
A
D
E
S



Power Curve Reciprocating Saw Blades



- Blade curvature positions teeth to cut more efficiently, resulting in a longer lasting blade
- Lasts up to twice as long as a straight blade
- Provides better performance on difficult materials, such as: nail-embedded wood, black pipe, unit-strut, and other construction materials.

| IBS No. | Size | TPI | Qty |
|---------|-----------------|-------|-----|
| 45904* | 9" x 3/4 x .035 | 4 tpi | 5 |

*While Supplies Last

Thick Demolition Reciprocating Saw Blades

Specially designed for the toughest demolition jobs. Cuts all woods, nail-embedded wood and metals.



THICK DEMOLITION RECIPROCATING SAW BLADES

| IBS No. | Size | TPI | Qty |
|---------|------------------|----------|-----|
| 460906 | 9" x 7/8 x .062 | 6 tpi | 2 |
| 460910 | 9" x 7/8 x .062 | 8/11 tpi | 2 |
| 461206 | 12" x 7/8 x .062 | 6 tpi | 2 |
| 461210 | 12" x 7/8 x .062 | 8/11 tpi | 2 |

Bore Blades™ Double Edge Bi-Metal Reciprocating Saw Blades

- **Double-sided** — so it cuts 3 ways making it versatile to cut in multiple directions and plunge cut saving users time and money.
- **Made with 8% cobalt** for exceptional strength and durability to provide long-lasting metal and wood cutting saving money on additional blades.
- **Round plunging tip** with ease to eliminate the need to drill first — saving the user time and money.
- **Double-edged blade cuts both ways** — just change direction as needed, saving the user time & money
- **Each blade has different TPI on each side** making them two blades for the cost of one — saving time and money on blade changeouts.



| IBS No. | Size | TPI | Qty |
|---------|------|---------------|-----|
| 446710 | 6" | 6 x 10 tpi | 5 |
| 446711 | 6" | 14 x 18 tpi | 5 |
| 448710 | 8" | 6 x 10 tpi | 5 |
| 448711 | 8" | 10 x 14 tpi | 5 |
| 4410710 | 10" | 8/12 x 10 tpi | 5 |

Tungsten Carbide Grit Reciprocating Saw Blades

Cutting edges have carbide grains bonded to an alloy backer and will not snag. Their super resistance to heat and shock make them ideal for materials too hard or abrasive for standard metal blades.

Recommended Use: Cutting fiberglass, lathe, plaster, ceramics, laminates, marble and hardened steel.



| IBS No. | Size | Qty |
|---------|----------|-----|
| 45699 | 6" x 3/4 | 2 |
| 45899 | 8" x 3/4 | 2 |

IBS, INCORPORATED

Hacksaw / Reciprocating Saw Blades (P11)



Reciprocating Saw Handle

- Instantly turn any standard reciprocating saw blade into a hand saw!
- Ergonomic handle with angled setting for additional leverage.
- Quick-twist lock securely holds any standard reciprocating saw blade or any 1/4" hex shank bit.
- Converts to a multi-bit screwdriver — handle stores 6 of the most popular bits: #5 & #6 Slotted, #1 & #2 Phillips and T15 and T20 Torx.
- Use to cut metal, wood, drywall and much more.



| IBS No. | RECIPROCATING SAW HANDLE | |
|---------|--------------------------|---|
| 44600 | Reciprocating Saw Handle | 1 |

Reciprocating Saw Handle & Blade Kit

IBS No. 706R • 7 Items • 11 Pcs (Z03)







Packaged in a plastic drawer for easy storage and organization



IBS, Inc.
SPECIALTY PRODUCTS FOR MAINTENANCE & REPAIR
INDUSTRIALDOLY.COM © © © 800-678-1906

**Reciprocating Saw
Handle & Blade Kit**

Assortment No. 706R

| | | | | |
|--|---|--|--|---|
| <p>44600 RECIPROCATING SAW HANDLE</p>  | <p>44606 6 6TPI BIMETAL RECIP BLADE*</p>  | <p>44610 6 10TPI BIMETAL RECIP BLADE*</p>  | <p>44618 6 18TPI BIMETAL RECIP BLADE*</p>  | <p>446710 6 7X10TPI BORE BLADE*</p>   <p>MBHL25225 1/4 X 2-1/4 MAG DRIVER BITHOLDER</p> |
|--|---|--|--|---|

T
A
P
S

B
U
R
S

B
L
A
D
E
S



IBS, INCORPORATED

Assortments (Z02)

T
A
P
S

B
U
R
S

B
L
A
D
E
S

Bore Blades and Demolition Blades

IBS No. 801R 9 Items • 18 Pcs (Z02)
Packaged in a locking steel drawer for easy storage & organization

| IBS, Inc. SPECIALTY PRODUCTS FOR MAINTENANCE & REPAIR INDUSTRIALBLADE.COM © © © 800-678-1998 | | Bore Blades and Demolition Blades |
|---|--|---|
| | | Assortment No. 801R |
| 446710 6' 6X10TPI BORE BLADE. For metal and wood cutting. | | 448711 8' 10X14TPI BORE BLADE. For metal and wood cutting. |
| 446711 6' 14X18TPI BORE BLADE. For metal and wood cutting. | | 4410710 10' 8/12X10TPI BORE BLADE. For metal and wood cutting. |
| 448710 8' 6X10TPI BORE BLADE. For metal and wood cutting. | | 460906 9 X .062 6TPI DEMOLITION BIMETAL RECIP BLADE Specially designed for the toughest demolition jobs. Cuts all woods, nail-embedded wood and metals. |
| 460910 9 X .062 10TPI DEMOLITION BIMETAL RECIP BLADE Specially designed for the toughest demolition jobs. Cuts all woods, nail-embedded wood and metals. | | |
| 461206 12 X .062 6TPI DEMOLITION BIMETAL RECIP BLADE Specially designed for the toughest demolition jobs. Cuts all woods, nail-embedded wood and metals. | | |
| 461210 12 X .062 10TPI DEMOLITION BIMETAL RECIP BLADE Specially designed for the toughest demolition jobs. Cuts all woods, nail-embedded wood and metals. | | |

Bi-Metal Reciprocating Saw Blades

IBS No. 512P 12 Items • 55 Pcs (Z08)
Packaged in a locking steel drawer for easy storage & organization

| IBS, Inc. SPECIALTY PRODUCTS FOR MAINTENANCE & REPAIR INDUSTRIALBLADE.COM © © © 800-678-1998 | | Hi-Alloy Reciprocating Saw Blades |
|--|--|--|
| | | Assortment No. 512P |
| 441206 12' 6TPI HI ALLOY RECIP BLADE Wood, nail-embedded wood, compositions plastic, cast aluminum, light gauge metals. | | |
| 44914 9 X 3/4 14TPI BIMETAL RECIP BLADE Heavy gauge metals of 18 gauge to 1/8" thick conduit, pipe, channels and tubing. | | 44918 9 X 3/4 18TPI BIMETAL RECIP BLADE Heavy gauge metals of 18 gauge to 1/8" thick conduit, pipe, channels and tubing. |
| 4481014 8' 10-14TPI HI ALLOY RECIP BLADE All woods, plastic, cast aluminum, nail-embedded wood, soil pipe. | | 44818 8 X 3/4 18TPI BIMETAL RECIP BLADE Heavy gauge metals of 18 gauge to 1/8" thick conduit, pipe, channels and tubing. |
| 44614 6' 14TPI HI ALLOY RECIP BLADE Heavy gauge metals 1/8" thick and above. Barstock and angles. | | 44618 6' 18TPI HI ALLOY RECIP BLADE Heavy gauge metals of 18 gauge to 1/8" thick conduit, pipe, channels and tubing. |
| 44610 6' 10TPI HI ALLOY RECIP BLADE Wood, nail-embedded wood, compositions plastic, cast aluminum, light gauge metals. | | 4461014 6' 10-14TPI HI ALLOY RECIP All woods, plastic, cast aluminum, nail-embedded wood, soil pipe. |
| 44606 6' 6TPI HI ALLOY RECIP BLADE Wood, nail-embedded wood, compositions plastic, cast aluminum, light gauge metals. | | 44656 6' 6TPI HI ALLOY RECIP BLADE Plaster with metal lathe plaster board, sheet rock, plaster walls. tooth design cuts both forward and on backward stroke. |

Special Purpose Reciprocating Saw Blades

IBS No. 393R • 7 Items • 14 Pcs (Z08)
Packaged in a Locking Steel Drawer for Easy Storage & Organization

| IBS, Inc. SPECIALTY PRODUCTS FOR MAINTENANCE & REPAIR INDUSTRIALBLADE.COM © © © 800-678-1998 | | Special Purpose Reciprocating Saw Blades |
|---|--|---|
| | | Assortment No. 393R |
| 44906 9 X 3/4 6TPI RECIP BIMETAL Wood, nail-embedded wood, compositions, plastic, cast aluminum, light gauge metals. | | |
| 45699 6 TUNGSTEN CARBIDE GRIT RECIP BLADE Cutting fiberglass, lathe, plaster, ceramics, laminates, marble and hardened steel. | | 45899 8 TUNGSTEN CARBIDE GRIT RECIP BLADE Cutting fiberglass, lathe, plaster, ceramics, laminates, marble and hardened steel. |
| 460906 9 X .062 6TPI DEMOLITION BIMETAL RECIP BLADE Specially designed for the toughest demolition jobs. Cuts all woods, nail-embedded wood and metals. | | |
| 461206 12 X .062 6TPI DEMOLITION BIMETAL RECIP BLADE Specially designed for the toughest demolition jobs. Cuts all woods, nail-embedded wood and metals. | | |
| 460910 9 X .062 10TPI DEMOLITION BIMETAL RECIP BLADE Specially designed for the toughest demolition jobs. Cuts all woods, nail-embedded wood and metals. | | |
| 461210 12 X .062 10TPI DEMOLITION BIMETAL RECIP BLADE Specially designed for the toughest demolition jobs. Cuts all woods, nail-embedded wood and metals. | | |

IBS, INCORPORATED

Hacksaw / Reciprocating Saw Blades (P11)



Bi-Metal Air Saw Blades

These blades are specifically designed for use in pneumatic saws. Blades have fine teeth for cutting metal. Very popular within autobody / muffler shops or other metal fabricating shops.



BI-METAL AIR SAW BLADES

| IBS No. | Size | TPI | Qty |
|---------|------------------|--------|-----|
| 441318 | 3" x 1/2" x .025 | 18 tpi | 5 |
| 441324 | 3" x 1/2" x .025 | 24 tpi | 5 |
| 441332 | 3" x 1/2" x .025 | 32 tpi | 5 |
| 441418 | 4" x 1/2" x .025 | 18 tpi | 5 |
| 441424 | 4" x 1/2" x .025 | 24 tpi | 5 |
| 441432 | 4" x 1/2" x .025 | 32 tpi | 5 |

Bi-Metal Air Saw Blades

IBS No. 513P • 6 Items • 30 Pcs (Z08)
Packaged in a locking plastic tray for easy storage & organization

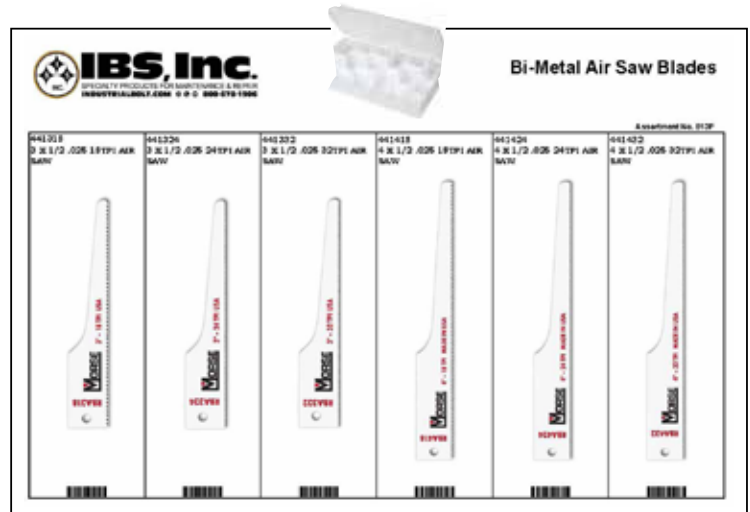

Bi-Metal Sabre/Jig Saw Blades

IBS Bi-Metal Sabre/Jig Saw Blades cut faster, cut straight, and last many times longer than high speed blades. Bi-metal construction consists of extra-sharp teeth milled in high speed steel welded to alloy back for longer life, and fewer changes. Tough sharp shatterproof bi-metal blades recommended for cutting steel, nail-embedded wood, masonite, conduit composition material, laminated countertops.

1/4" Universal Shank



Metal 18 gauge and under.

| IBS No. | Size | TPI | Qty |
|---------|------------------|--------|-----|
| 442718 | 3" x 3/8" x .035 | 18 tpi | 5 |

T
A
P
S
B
U
R
S
B
L
A
D
E
S



IBS, INCORPORATED

Razor Blades P11

T
A
P
S
B
U
R
S
B
L
A
D
E
S

"Rapid Razor" Utility Knife



- Autoloading design
- One-button blade change - 5 blades included
- Ergonomic rubber grip
- Heavy duty die cast body
- Holds any standard utility or hook blade
- 5 blades included

| IBS No. | Description | Qty |
|---------|---------------------------------|-----|
| 16402 | IBS "Rapid Razor" Utility Knife | 1 |

"Rapid Razor" Dispenser 75 Blades/Pkg

- Dispenses 2-notch blades quickly and easily.
- Dispenser is wall mountable for convenient and easy access.
- Convenient see-thru body for easy visual check of supply.
- Built-in blade disposal slot for added safety.
- **MADE IN THE USA**



| IBS No. | Description | Qty |
|---------|-----------------------------|-----|
| 16407 | IBS "Rapid Razor" Dispenser | 1 |

Heavy Duty Blades

- .025 Gauge.
- Fits most standard knives.
- Long lasting.
- All purpose blades.
- Made in the USA.



| IBS No. | Description | Qty |
|---------|----------------------------------|-----|
| 16406 | 3 Notch Heavy Duty Utility Blade | 5 |

Cartridge Loading Snap Knife with Rubber Grip



- Autoloading design
- Blade cartridge w/6 premium 8 pt blades
- Ratchet wheel for blade stability
- Ergonomic rubber grip
- Auto-locking
- For replacement blades use IBS No. 16409

| IBS No. | Description | Qty |
|---------|------------------------------|-----|
| 16408 | Cartridge Loading Snap Knife | 1 |

HD Retractable Blade 8 Pt. Breakaway Knife



- Steel blade track.
- Auto-locking
- High-visibility yellow.
- Comes with premium steel blades.
- Accepts all standard 8 point blades.
- Spare blade compartment.
- Ideal for cutting cardboard, wood, leather and more.
- For replacement blades use IBS No. 16409

| IBS No. | Description | Qty |
|---------|--------------------------------|-----|
| 16403 | HD Retractable Breakaway Knife | 1 |

Utility Knife Holster

- Sturdy metal clip.
- Universal use.
- Belt slots.
- High quality leather construction.
- Holds most utility knives & safety cutters.
- Made in the USA.



| IBS No. | Description | Qty |
|---------|-----------------------|-----|
| 16410 | Utility Knife Holster | 1 |

Heavy Duty Hook Blades

- Use with IBS Rapid Razor 16402.
- Ideal for cutting roofing, linoleum and carpet.
- .025 Gauge.
- Fits most standard knives.
- Long lasting.
- Made in the USA.



| IBS No. | Description | Qty |
|---------|-------------------------------|-----|
| 16412 | Heavy Duty Hook Utility Blade | 5 |

HD 8 PT Snap Blade

- Use with IBS No. 16403 & 16408.
- Heavy Duty.
- Fits all standard snap knives.



| IBS No. | Description | Qty |
|---------|------------------------------|-----|
| 16409 | HD 8 PT Snap Blade - 10 Pack | 1 |



Plastic Razor Blades

- Double Edged for longer life.
- Use with IBS No. 16400 & 16424.
- Made for safer scraping and cleaning.
- Prevents damage to delicate surfaces.
- Fits most standard knives.
- Will not rust or corrode like metal blades.



| IBS No. | Description | Qty |
|---------|----------------------|-----|
| 16401 | Plastic Razor Blades | 50 |

Single Edge Razor Blades

- Use with IBS No. 16400 & 16424.
- Fits all standard single edge tools.
- Double honed for extra sharp edge.
- Strong steel back will not bend.
- Individually wrapped for edge protection and safety.
- Innovative packaging easily dispenses each blade thru top slot.
- Storage slot in the bottom for disposal of used blades.
- **MADE IN USA**



| IBS No. | Description | Qty |
|---------|--------------------------|-----|
| 16405 | Single Edge Razor Blades | 100 |

Revo Folding Knife

- Comfort-grip finger loop for added safety and control.
- Two position cutting.
- 50% more blade-edge exposed for deeper cutting.
- Quick-change blade replacement.
- Metal belt clip.
- Use with IBS No. 16407 IBS Rapid Razor 100 BLADES/PK (purchase separately).



| IBS No. | Description | Qty |
|---------|--------------------|-----|
| 16416 | Revo Folding Knife | 1 |

Heavy Duty Metal Scraper

- Protective cap keeps the blade covered until it is in use. The cover then snaps on the back of the scraper to keep from losing or misplacing the cap.
- Ergonomic grip for better control.
- No push-button slide to expose the blade which often causes the blade to slide back when in use.
- Includes one standard straight razor blade for added value and allows the scraper to be used immediately.
- Perfect for scraping labels, decals, paint and adhesive from glass and other surfaces.



Overall length is 9-1/4 inches*

| IBS No. | Description | Qty |
|---------|------------------------------------|-----|
| 16400 | Heavy Duty Metal Scraper | 1 |
| 16424* | Heavy Duty Extended Scraper 9-1/4" | 1 |

Serrated Blades

100 Blades/Pkg

- **Sharp Serrated Blades** – Rapid Edge serrated utility knife blades feature multiple cutting edges that distribute friction evenly for faster, smoother cuts, and prolonged blade life.
- **All-Purpose Use** – These razor knife blades easily cut materials like cardboard, drywall, rubber, and carpet. Tackle projects without worrying about dull box knife blades.
- **Cost-Effective Bulk Pack** – Each pack includes 100 serrated utility knife blades, providing a reliable supply for offices, warehouses, or construction projects.
- **Seamless Compatibility** – These refill box cutter blades fit standard safety knives and Rapid Edge utility knives. Upgrade your existing tools with Rapid Edge serrated utility blades!
- **Durable Construction** – Made from alloy steel, Rapid Edge blades withstand tough jobs. Our serrated utility blades last longer than standard single-edge utility razor blades.



| IBS No. | Description | Qty |
|---------|------------------------|-----|
| 16415 | 100 PK Serrated Blades | 1 |

T
A
P
S
B
U
R
S
B
L
A
D
E
S



T
A
P
S
B
U
R
S
B
L
A
D
E
S

Fiskars® Pro Fixed Blade Utility Knife

- The advantage of a "Fixed" Utility Knife is the blade is held securely and firmly in the knife for no wobble or slippage while in use for safer and more consistent cutting action.
- Folding blade guard deploys with the push of a button for convenient, easy protection.
- A reinforced metal end provides sturdy, reliable resistance against pounding and drops.
- The knife hinges open for easy blade change with no loose parts to keep track of.
- Includes one utility blade & handy 5 blade storage capacity meaning a new sharp blade is easily available to keep working, saving time and money.
- Manufacturer's Full Lifetime Warranty.



| IBS No. | Description | Qty |
|---------|---------------------------------------|-----|
| 16417 | Fiskars Pro Fixed Blade Utility Knife | 1 |

Fiskars® Pro Retractable Blade Utility Knife

- Side blade actuation on the knife helps prevent accidental blade retraction while in use.
- Knife easily hinges open with no loose parts to keep track of during blade change.
- Reinforced metal end provides sturdy, reliable resistance against pounding and drops.
- Includes one utility blade & handy 5 blade storage capacity meaning a new sharp blade is easily available to keep working, saving time and money.
- Manufacturer's Full Lifetime Warranty.



| IBS No. | Description | Qty |
|---------|---------------------------------------|-----|
| 16418 | Fiskars Pro Retractable Utility Knife | 1 |

Fiskars® Pro Folding Utility Knife



The Fiskars® Pro-Folding Utility Knife is a reliable, do-it-all addition to your tool kit and folds for compact storage and portability.

- Fiskars® Pro Folding Utility knife features a dual -locking system that prevents accidental blade release without sacrificing blade-change speed.
- Easy, one-handed, flip-open design means the knife opens with the flick of a wrist — safely reach the knife and continue working without interruption.
- Unique blade-release button makes for fast and easy blade changes — just press and sweep to release the blade and slide in a new one.
- Ergonomic design, including deep grooves and contouring allows for multiple grips.
- The reinforced metal end provides sturdy, reliable resistance against pounding and drops.
- Includes one utility blade.
- Manufacturer's Full Lifetime Warranty.

| IBS No. | Description | Qty |
|---------|-----------------------------------|-----|
| 16419 | Fiskars Pro Folding Utility Knife | 1 |

IBS, INCORPORATED

Snips, Shears & Pipe Cutters P11



Fiskars® PowerArc Utility Snips (8")



- PowerArc™ Utility Snips boast **intelligently curved blades** that alter the angle between the blades to give you over 2X more power, especially during the toughest part of the cut.
- **Offset design** with heavy-duty stainless steel blades can be used to cut materials from above or below, keeping waste material away from your hand.
- An **ergonomic, spring-assisted handle** helps reduce hand fatigue and features Softgrip® for enhanced dexterity and comfort.
- A **serrated edge, extended tang and bolted joint** improve control and durability.

| IBS No. | Description | Qty |
|---------|---------------------------------|-----|
| 16420 | Fiskars PowerArc™ Utility Snips | 1 |

Fiskars® PowerArc Easy Action Shears (10")



- PowerArc™ Easy Action Shears™ boast **intelligently curved blades** that alter the angle between the blades to give you over 2X more power, especially during the toughest part of the cut.
- A radically **ergonomic, spring-assisted handle** features an open top loop, allowing you to rotate your hand over the handle to apply more power, especially during the toughest part of the cut.
- In addition, **Softgrip®** enhances dexterity and comfort, a bigger bottom loop fits large gloved hands and an easy-open lock protects the blades during transport.
- **Heavy-duty coined stainless steel blades** help prevent separation.
- A **serrated edge, extended tang and bolted joint** improve control and durability.

| IBS No. | Description | Qty |
|---------|--------------------------------------|-----|
| 16421 | Fiskars PowerArc™ Easy Action Shears | 1 |

Fiskars® PowerGear Plastic Pipe Cutter



- **PowerGear® technology** gives you over 35% more power to make cutting plastic pipes easier, while eliminating the need for ratcheting.
- This ingenious technology features a gear that provides more power during the toughest parts of the cut.
- **Replaceable stainless steel blades** cut from start to finish in a single, smooth stroke, while a tough stainless exoskeleton maximizes durability.
- An **ergonomic, spring-assisted handle** helps reduce hand fatigue and features Softgrip for enhanced dexterity and comfort.
- An **easy-open lock** simplifies usage while cutting a range of plastic pipes, including up to 1-1/4" O.D. PVC.

| IBS No. | Description | Qty |
|---------|---|-----|
| 16422 | Fiskars PowerGear™ Plastic Pipe Cutter | 1 |
| 16423 | Replacement Blade for Fiskars PowerGear Plastic Pipe Cutter | 1 |

T
A
P
S
B
U
R
S
B
L
A
D
E
S



IBS, INCORPORATED

Rotary Burs P29

Solid Carbide Burs

Double, Saber Cut and Fast Mill Flutes • 1/4" Shank

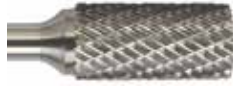

Double Cut

- For use on **hardened** and **tough materials**, stainless steel, cast steel and plastics.
- Produces a finer finish on material.
- Creates smaller chips and slivers.
- Provides greater tool control.



Saber Cut

- For use in **mild steel** and other semi-hard materials.
- Maximum stock removal.
- Engineered for heavy duty applications.
- Wider teeth make longer chips that break up easier and less prone to clogging.



Fast Mill Cut

- For use on **aluminum**, non-ferrous metals, soft steel, reinforced plastics, rubber, wood and other soft materials.
- Provides easy chip flow and faster stock removal without clogging.



Also Available in Extended 6" Lengths

FEATURES/BENEFITS:

- **Manufactured from C2 grade carbide** for high performance metal removal.
- **Perfect for edge and surface working**
- **Offered in various shapes available to match with the job** being done for fast, efficient and clean work.
- **1/4" shank fits all standard grinders.**



CYLINDER CARBIDE BUR

| IBS No. | | | SCTI No. | Head Dia | Head Length | Overall Length |
|------------|-----------|---------------|----------|----------|-------------|----------------|
| Double Cut | Saber Cut | Fast Mill Cut | | | | |
| 16901 | 16906 | 16981 | SA-1 | 1/4 | 5/8 | 2 |
| 16903 | 16907 | 16983 | SA-3 | 3/8 | 3/4 | 2-1/2 |
| 16905 | 16909 | 16985 | SA-5 | 1/2 | 1 | 2-3/4 |



CYLINDER END CUT CARBIDE BUR

| IBS No. | | | SCTI No. | Head Dia | Head Length | Overall Length |
|------------|-----------|---------------|----------|----------|-------------|----------------|
| Double Cut | Saber Cut | Fast Mill Cut | | | | |
| 18901 | — | — | SB-1 | 1/4 | 5/8 | 2 |
| 18903 | — | — | SB-3 | 3/8 | 3/4 | 2-1/2 |
| 18905 | — | — | SB-5 | 1/2 | 1 | 2-3/4 |



CYLINDER-RADIUS END CARBIDE BUR

| IBS No. | | | SCTI No. | Head Dia | Head Length | Overall Length |
|------------|-----------|---------------|----------|----------|-------------|----------------|
| Double Cut | Saber Cut | Fast Mill Cut | | | | |
| 16931 | — | — | SC-1 | 1/4 | 5/8 | 2 |
| 16933 | 16936 | 16987 | SC-3 | 3/8 | 3/4 | 2-1/2 |
| 16935 | 16938 | 16989 | SC-5 | 1/2 | 1 | 2-3/4 |

T
A
P
S
B
U
R
S
B
L
A
D
E
S

Rotary Burs P29

Solid Carbide Burs

Double, Saber and Fast Mill Cut Flutes • 1/4" Shank



BALL SHAPE CARBIDE BUR

| IBS No. | | | SCTI No. | Head Dia | Head Length | Overall Length |
|------------|-----------|---------------|----------|----------|-------------|----------------|
| Double Cut | Saber Cut | Fast Mill Cut | | | | |
| 16971 | — | — | SD-1 | 1/4 | 7/32 | 2 |
| 16972 | — | — | SD-2 | 5/16 | 5/16 | 2-1/16 |
| 16973 | 16976 | — | SD-3 | 3/8 | 5/16 | 2-1/16 |
| 16975 | 16977 | — | SD-5 | 1/2 | 7/16 | 2-3/16 |



OVAL CARBIDE BUR

| IBS No. | | | SCTI No. | Head Dia | Head Length | Overall Length |
|------------|-----------|---------------|----------|----------|-------------|----------------|
| Double Cut | Saber Cut | Fast Mill Cut | | | | |
| 16941 | — | — | SE-1 | 1/4 | 3/8 | 2 |
| 16943 | 16946 | — | SE-3 | 3/8 | 5/8 | 2-11/32 |
| 16945 | 16948 | — | SE-5 | 1/2 | 7/8 | 2-5/8 |



TREE RADIUS END CARBIDE BUR

| IBS No. | | | SCTI No. | Head Dia | Head Length | Overall Length |
|------------|-----------|---------------|----------|----------|-------------|----------------|
| Double Cut | Saber Cut | Fast Mill Cut | | | | |
| 16911 | — | — | SF-1 | 1/4 | 5/8 | 2 |
| 16913 | 16916 | 16991 | SF-3 | 3/8 | 3/4 | 2-1/2 |
| 16915 | 16918 | 16993 | SF-5 | 1/2 | 1 | 2-3/4 |
| — | — | 16995 | SF-6 | 5/8 | 1 | 2-3/4 |



TREE POINTED END CARBIDE BUR

| IBS No. | | | SCTI No. | Head Dia | Head Length | Overall Length |
|------------|-----------|---------------|----------|----------|-------------|----------------|
| Double Cut | Saber Cut | Fast Mill Cut | | | | |
| 16951 | — | — | SG-1 | 1/4 | 5/8 | 2 |
| 16953 | 16956 | — | SG-3 | 3/8 | 3/4 | 2-1/2 |
| 16955 | 16958 | — | SG-5 | 1/2 | 1 | 2-3/4 |



14° TAPER - RADIUS CARBIDE BUR

| IBS No. | | | SCTI No. | Head Dia | Head Length | Overall Length |
|------------|-----------|---------------|----------|----------|-------------|----------------|
| Double Cut | Saber Cut | Fast Mill Cut | | | | |
| 16921 | — | — | SL-1 | 1/4 | 5/8 | 2 |
| 16923 | 16926 | — | SL-3 | 3/8 | 1-1/16 | 2-13/16 |
| 16924 | 16927 | — | SL-4 | 1/2 | 1-1/8 | 2-7/8 |



CONE SHAPE CARBIDE BUR

| IBS No. | | | SCTI No. | Angle | Head Dia | Head Length | Overall Length |
|------------|-----------|---------------|----------|-------|----------|-------------|----------------|
| Double Cut | Saber Cut | Fast Mill Cut | | | | | |
| 16963 | — | — | SM-3 | 12° | 1/4 | 1 | 2 |
| 16964 | 16966 | — | SM-4 | 28° | 3/8 | 3/4 | 2-1/2 |
| 16965 | 16967 | — | SM-5 | 28° | 1/2 | 1 | 2-3/4 |

T
A
P
S

B
U
R
S

B
L
A
D
E
S



IBS, INCORPORATED

Rotary Burs P29

Carbide Bur Assortments (P15)

TAPS
BURS
BLADES



DOUBLE CUT ROTARY BURS ASSORTMENT

| Asst No. | IBS No. (Bur) | Type | SCTI No. | Head Dia | Head Length | Overall Length | | |
|-----------------------------------|--------------------------|-------|---------------------|----------|-------------|----------------|---------|--|
| IBS No. 16980 w / Index & Grinder | IBS No. 16979 with Index | 16901 | Cylinder | SA-1 | 1/4 | 5/8 | 2 | |
| | | 16903 | Cylinder | SA-3 | 3/8 | 3/4 | 2-1/2 | |
| | | 16905 | Cylinder | SA-5 | 1/2 | 1 | 2-3/4 | |
| | | 16921 | 14° Taper | SL-1 | 1/4 | 5/8 | 2-13/16 | |
| | | 16933 | Cylinder Rad | SC-3 | 3/8 | 3/4 | 2-1/2 | |
| | | 16935 | Cylinder Rad | SC-5 | 1/2 | 1 | 2-3/4 | |
| | | 16911 | Tree Radius | SF-1 | 1/4 | 5/8 | 2-1/2 | |
| | | 16913 | Tree Radius | SF-3 | 3/8 | 3/4 | 2-3/4 | |
| | | 17016 | Steel Index | | | | | |
| | | 69282 | 1/4 Air Die Grinder | | | | | |



SABER CUT ROTARY BURS ASSORTMENT

| Asst No. | IBS No. (Bur) | Type | SCTI No. | Head Dia | Head Length | Overall Length | | |
|---------------------------------|--------------------------|-------|---------------------|----------|-------------|----------------|---------|--|
| IBS No. 16996 w/Index & Grinder | IBS No. 16997 with Index | 16907 | Cylinder | SA-3 | 3/8 | 3/4 | 2-1/2 | |
| | | 16909 | Cylinder | SA-5 | 1/2 | 1 | 2-3/4 | |
| | | 16926 | 14° Taper | SL-3 | 3/8 | 1-1/16 | 2-13/16 | |
| | | 16936 | Cylinder Rad | SC-3 | 3/8 | 3/4 | 2-1/2 | |
| | | 16938 | Cylinder Rad | SC-5 | 1/2 | 1 | 2-3/4 | |
| | | 16916 | Tree Radius | SF-3 | 1/2 | 1 | 2-1/2 | |
| | | 16918 | Tree Radius | SF-5 | 3/8 | 3/4 | 2-3/4 | |
| | | 17016 | Steel Index | | | | | |
| | | 69282 | 1/4 Air Die Grinder | | | | | |



FAST MILL CUT BURS FOR ALUMINUM ASSORTMENT

| Asst No. | IBS No. (Bur) | Type | SCTI No. | Head Dia | Head Length | Overall Length | | |
|---------------------------------|-----------------------|-------|---------------------|----------|-------------|----------------|-------|--|
| IBS No. 16998 w/Index & Grinder | IBS No. 16999 w/Index | 16981 | Cylinder | SA-1 | 1/4 | 5/8 | 2 | |
| | | 16983 | Cylinder | SA-3 | 3/8 | 3/4 | 2-1/2 | |
| | | 16985 | Cylinder | SA-5 | 1/2 | 1 | 2-3/4 | |
| | | 16987 | Cylinder Rad | SC-3 | 3/8 | 3/4 | 2-1/2 | |
| | | 16989 | Cylinder Rad | SC-5 | 1/2 | 1 | 2-3/4 | |
| | | 16993 | Tree Radius | SF-5 | 1/2 | 1 | 2-1/2 | |
| | | 17016 | Steel Index | | | | | |
| | | 69282 | 1/4 Air Die Grinder | | | | | |



IBS, INCORPORATED

Hi-Alloy Rotary Burs Gen'l Info



| SURFACE FEET CONVERSION CHART | | | | | | | | |
|---|-----------------|-------|-------|-------|-------|-------|------|------|
| Surface Feet Per Minute (SFM) to Revolutions Per Minute (RPM) | | | | | | | | |
| SFM | RPM | | | | | | | |
| | Cutter Diameter | | | | | | | |
| | 1/8" | 1/4" | 3/8" | 1/2" | 5/8" | 3/4" | 7/8" | 1" |
| 10 | 305 | 153 | 102 | 76 | 61 | 51 | 44 | 38 |
| 15 | 458 | 229 | 153 | 115 | 92 | 76 | 65 | 57 |
| 20 | 611 | 305 | 204 | 153 | 122 | 102 | 87 | 76 |
| 25 | 763 | 382 | 254 | 191 | 153 | 127 | 109 | 95 |
| 30 | 916 | 458 | 305 | 229 | 183 | 153 | 131 | 115 |
| 25 | 1069 | 534 | 356 | 267 | 214 | 178 | 153 | 134 |
| 40 | 1221 | 611 | 407 | 206 | 244 | 204 | 174 | 153 |
| 25 | 1374 | 687 | 458 | 344 | 275 | 229 | 196 | 172 |
| 50 | 1527 | 763 | 509 | 382 | 305 | 254 | 218 | 191 |
| 60 | 1832 | 916 | 611 | 458 | 366 | 305 | 262 | 229 |
| 70 | 2137 | 1069 | 712 | 534 | 427 | 356 | 305 | 267 |
| 80 | 2443 | 1221 | 814 | 611 | 489 | 407 | 349 | 305 |
| 90 | 2478 | 1374 | 916 | 687 | 550 | 458 | 393 | 344 |
| 100 | 3053 | 1527 | 1018 | 763 | 611 | 509 | 436 | 382 |
| 150 | 4580 | 2290 | 1527 | 1145 | 916 | 763 | 654 | 573 |
| 200 | 6107 | 3053 | 2036 | 1527 | 1221 | 1018 | 872 | 763 |
| 250 | 7634 | 3817 | 2545 | 1908 | 1527 | 1272 | 1091 | 954 |
| 300 | 9160 | 4580 | 3053 | 2290 | 1832 | 1527 | 1309 | 1145 |
| 350 | 10687 | 5344 | 3562 | 2672 | 2137 | 1781 | 1527 | 1336 |
| 400 | 12214 | 6107 | 4071 | 3053 | 2443 | 2036 | 1745 | 1527 |
| 450 | 13740 | 6870 | 4580 | 3453 | 2748 | 2290 | 1963 | 1718 |
| 500 | 15267 | 7634 | 5089 | 3817 | 3053 | 2545 | 2181 | 1908 |
| 600 | 18321 | 9160 | 6107 | 4580 | 3664 | 3053 | 2617 | 2290 |
| 700 | 21374 | 10687 | 7125 | 5344 | 4275 | 3562 | 3053 | 2672 |
| 800 | 24427 | 12214 | 8142 | 6107 | 4885 | 4071 | 3490 | 3053 |
| 900 | 27481 | 13740 | 9160 | 6870 | 5496 | 4580 | 3926 | 3453 |
| 1000 | 30534 | 15267 | 10178 | 7634 | 6107 | 5089 | 4362 | 3817 |
| 1100 | 33588 | 16794 | 11196 | 8397 | 6718 | 5598 | 4798 | 4198 |
| 1200 | 36641 | 18321 | 12214 | 9160 | 7328 | 6107 | 5234 | 4580 |
| 1300 | 39695 | 19847 | 13232 | 9924 | 7939 | 6616 | 5671 | 4962 |
| 1400 | 42748 | 21374 | 14429 | 10687 | 8550 | 7125 | 6107 | 5344 |
| 1500 | 45802 | 22901 | 15267 | 11450 | 9160 | 7634 | 6543 | 5725 |
| 1600 | 48855 | 24427 | 16285 | 12214 | 9771 | 8142 | 6979 | 6107 |
| 1700 | 51908 | 25954 | 17303 | 12977 | 10382 | 8651 | 7415 | 6489 |
| 1800 | 54962 | 27481 | 18321 | 13740 | 10992 | 9160 | 7852 | 6870 |
| 1900 | 58015 | 29008 | 19338 | 14504 | 11603 | 9669 | 8288 | 7252 |
| 2000 | 61069 | 30534 | 20356 | 15267 | 12214 | 10178 | 8724 | 7634 |

FORMULAS: SFM = RPM X Diameter X .262 RPM = (SFM X 3.82) + Diameter

T
A
P
S

B
U
R
S

B
L
A
D
E
S



External Deburring Tools (T03)



- Quickly repairs damaged threads from 7/64" to 7/8".
- Hardened HRC 60 Steel blades remove burrs and uneven ridges from threaded rods, pipes and more.
- Works on hardened and mild steels, Grade 8 fasteners, stainless steel, brass copper, aluminum, plastics, wood, etc.
- 1/4" hex shank attaches to your drill quickly.
- Most effective at low speeds — recommended speed should not exceed 500 RPM in a clockwise direction only.

| IBS No. | Description | Shank | Qty |
|---------|-------------------------------------|-------|-----|
| 51951 | Small Deburring Tool 7/64" to 7/16" | 1/4" | 1 |
| 51950 | Medium Deburring Tool 5/16" to 7/8" | 1/4" | 1 |

T
A
P
S

B
U
R
S

B
L
A
D
E
S



REMOVE BURS

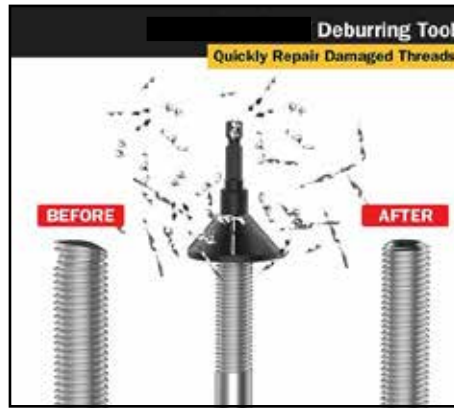

REPAIR DAMAGED THREADS



WORKS ON A VARIETY OF MATERIALS



Black Maxi-Sharp Files

Our Premium line of hand files, specially treated with a black oxide coating, Black Maxi-Sharp Files last longer due to increased resistance to loading and rust.

All Purpose



The built-in handle provides maximum versatility for a wide range of applications. All Purpose Files feature a double cut on one side, a single cut on the other side, have one edge cut and one edge safe (uncut) for shoulder filing, and are parallel in width and thickness.

ALL PURPOSE

| IBS No. | Description | Qty |
|----------|--------------|-----|
| 65018-8 | 8" / 200 mm | 1 |
| 65018-10 | 10" / 250 mm | 1 |

Mill Files



Excellent for a wide range of applications such as sharpening, draw filing, lathe work and general shop use; Mill Files are single cut on the sides and edges and taper toward the point width.

MILL FILES - BASTARD CUT

| IBS No. | Description | Qty |
|----------|--------------|-----|
| 65000-6 | 6" / 150 mm | 1 |
| 65000-8 | 8" / 200 mm | 1 |
| 65000-10 | 10" / 250 mm | 1 |
| 65000-12 | 12" / 300 mm | 1 |
| 65000-14 | 14" / 350 mm | 1 |

MILL FILES - SMOOTH CUT

| IBS No. | Description | Qty |
|----------|--------------|-----|
| 65017-6 | 6" / 150 mm | 1 |
| 65017-8 | 8" / 200 mm | 1 |
| 65017-10 | 10" / 250 mm | 1 |
| 65017-12 | 12" / 300 mm | 1 |

MILL FILES - SECOND CUT

| IBS No. | Description | Qty |
|----------|--------------|-----|
| 65010-6 | 6" / 150 mm | 1 |
| 65010-8 | 8" / 200 mm | 1 |
| 65010-10 | 10" / 250 mm | 1 |

Flat Files



Excellent for "hogging" or rapid stock removal; Flat Files are double cut on both sides, single cut on the edges and taper toward the point in width.

FLAT FILES - BASTARD CUT

| IBS No. | Description | Qty |
|----------|--------------|-----|
| 65001-6 | 6" / 150 mm | 1 |
| 65001-8 | 8" / 200 mm | 1 |
| 65001-10 | 10" / 250 mm | 1 |
| 65001-12 | 12" / 300 mm | 1 |
| 65001-14 | 14" / 350 mm | 1 |

FLAT FILES - SMOOTH CUT

| IBS No. | Description | Qty |
|----------|--------------|-----|
| 65011-6 | 6" / 150 mm | 1 |
| 65011-8 | 8" / 200 mm | 1 |
| 65011-10 | 10" / 250 mm | 1 |
| 65011-12 | 12" / 300 mm | 1 |

Half-Round Files



Great for rounding out holes, corners and crevices; Half Round Files are double cut on both sides and taper toward the point in width and thickness. Files feature a "twist & roll" action on the half round side produced by a spiral cut design and have the "Wavy Tooth" design on the flat side

HALF ROUND FILES - BASTARD CUT

| IBS No. | Description | Qty |
|----------|--------------|-----|
| 65003-6 | 6" / 150 mm | 1 |
| 65003-8 | 8" / 200 mm | 1 |
| 65003-10 | 10" / 250 mm | 1 |
| 65003-12 | 12" / 300 mm | 1 |
| 65003-14 | 14" / 350 mm | 1 |

HALF ROUND FILES - SMOOTH CUT

| IBS No. | Description | Qty |
|----------|--------------|-----|
| 65014-6 | 6" / 150 mm | 1 |
| 65014-8 | 8" / 200 mm | 1 |
| 65014-10 | 10" / 250 mm | 1 |

T
A
P
S

B
U
R
S

B
L
A
D
E
S



IBS, INCORPORATED

Abrasives, Bench Rolls, Files P26

T
A
P
S
B
U
R
S
B
L
A
D
E
S

Black Maxi-Sharp Files

Our Premium line of hand files, specially treated with a black oxide coating, Black Maxi-Sharp Files last longer due to increased resistance to loading and rust.

Multi-Kut Flat Files



Obtain almost any required finish simply by changing the feed pressure; "Multi-Kut" Flat Files are single cut coarse tooth files that taper toward the point width. Design features allow for fast stock removal while leaving a smooth finish. Combines the performances of Flat and Mill Files.

MULTI-KUT FLAT FILES - SMOOTH CUT

| IBS No. | Description | Qty |
|----------|--------------|-----|
| 65019-8 | 8" / 200 mm | 1 |
| 65019-10 | 10" / 250 mm | 1 |

Round Files



Intended for enlarging and rounding out circular openings or concave surfaces; Round Files are double cut and taper toward the point in width and thickness.

ROUND FILES - BASTARD CUT

| IBS No. | Description | Qty |
|----------|--------------|-----|
| 65002-6 | 6" / 150 mm | 1 |
| 65002-8 | 8" / 200 mm | 1 |
| 65002-10 | 10" / 250 mm | 1 |
| 65002-12 | 12" / 300 mm | 1 |

ROUND FILES - SMOOTH CUT

| IBS No. | Description | Qty |
|---------|-------------|-----|
| 65012-6 | 6" / 150 mm | 1 |
| 65012-8 | 8" / 200 mm | 1 |

Tapered Saw Files



Designed for filing all types of saws with 60° angle teeth; Taper Saw Files are triangular in shape, have cut edges and taper toward the point in width and thickness.

| IBS No. | Description | Type | Qty |
|---------|---------------|------------|-----|
| 65016-6 | 6" / 150 mm ▲ | Regular | 1 |
| 65004-6 | 6" / 150 mm ▲ | Slim | 1 |
| 65005-7 | 6" / 150 mm ▲ | Extra Slim | 1 |

3 Square Files



Excellent for cleaning out corners or for use on cutters, taps, and flat surfaces; Three Square files are double cut and taper toward the point in width and thickness

| IBS No. | Description | Type | Qty |
|---------|-------------|-------------|-----|
| 65015-6 | 6" / 150 mm | Bastard Cut | 1 |
| 65015-8 | 8" / 200 mm | Bastard Cut | 1 |

Tungsten Points File with Pocket Clip



For cleaning contact points in magnetos, switches, electric bells and distributor points and spark plugs in engines; Tungsten Point Files are single cut and have a handy pocket clip.

| IBS No. | Description | Qty |
|---------|--------------------------------------|-----|
| 65006-6 | 5" Tungsten Points File w / Pkt Clip | 1 |

Chainsaw Files



Used for sharpening and maintaining proper tooth shape on chain saws; Round Chain Saw files have a fast, smooth cutting action that leaves an excellent "keen" edge cutting finish.

| IBS No. | Description | Qty |
|-----------|-------------|-----|
| 65007-14 | 1/4" x 8" | 1 |
| 65007-316 | 3/16" x 8" | 1 |
| 65007-532 | 5/32" x 6" | 1 |
| 65007-732 | 7/32" x 8" | 1 |

File Card



Used to clean files — files last longer when properly cleaned. Excess build-up can cause clogging, resulting in slipping, scratching, or other filing inefficiencies.

| IBS No. | Description | Qty |
|---------|----------------------|-----|
| 65009 | File Card with Brush | 1 |



Files & Accessories Skroo-Zon File Handles



The best name in file handles, Skroo-Zon wooden file handles have a threaded insert for "easy on, easy off." Reusable and long lasting. Be safe and reduce the risk of injury; use a Skroo-Zon File Handle.

| IBS No. | Description | Qty |
|----------|-----------------------|-----|
| 65008-4 | T2 Handle / 4" Files | 1 |
| 65008-6 | T4 Handle / 6" Files | 1 |
| 65008-8 | T5 Handle / 8" Files | 1 |
| 65008-10 | T6 Handle / 10" Files | 1 |
| 65008-12 | T7 Handle / 12" Files | 1 |
| 65008-14 | T8 Handle / 14" Files | 1 |

T
A
P
S

B
U
R
S

B
L
A
D
E
S

Black Maxi-Sharp Files Assortment (Z02)

IBS No. 699R • 10 Items • 12 Pcs

Packaged in a locking steel drawer for easy storage & organization

Maxi-Sharp Files

Assortment No. 699R

65018-10
10 MAXI-SHARP ALL PURPOSE

65001-10
10 MAXI-SHARP FLAT FILE

65000-10
10 MAXI-SHARP MILL FILE

65002-10
10 MAXI-SHARP ROUND FILE

65004-6
6 MAXI-SHARP TAPER FILE SLIM

65009
FILE CARD WITH BRUSH

65019-10
10 MAXI-SHARP FLAT MULTI-KUT

65003-10
10 MAXI-SHARP 1/2 RD FILE

65008-6
6 SCRUIZ-ON FILE HANDLE

65008-10
10 SCRUIZ-ON FILE HANDLE



T
A
P
S

B
U
R
S

B
L
A
D
E
S



Drill Bits, Inserts & Reamers

A

Assortments, Cutting Tool

Countersinks, Fluteless

Hex & Round Shank PD-27

Draps, IBS Nitro Carb

6 Pc Coarse Machine Screwn Nitro Carb Tap Set PD-34

6 Pc Machine Screw Nitro Carb Tap Travel Tray PD-34

6 Pc Metric Nitro Carb Tap Travel Tray PD-34

7 Pc Coarse Thread Nitro Carb Tap Set PD-34

7 Pc Fine Thread Nitro Carb Tap Set PD-34

Drill Bits, Nitro-Carb

7 Pc. Nitro-Carb Mech Length Drill Bit Set - Pouch PD-13

12 Pc. Nitro-Carb Mech Length Drill Bit Set - Hard Case PD-13

16 Pc. Nitro-Carb Mech Length Drill Bit Set - Pouch PD-13

IBS Type 187 Spotweld PD-25

Left Hand Drill Bit PD-18

Letter PD-12

Number PD-12

Quick Release Drill Bit & Insert PD-13

Reduced Shank PD-14, PD-15

Stubby PD-20

Drill Bits, Nitro-X

13 Pc Nitro-X Step Tip Mechanics Length Handi-Bit Set 1/16 X 1/2 by 32nds PD-3

29 Pc Nitro-X Step Tip Mechanics Length Set 1/16 X 1/2 by 64ths PD-3

51 Pc. Nitro-X StepTip Mechanic's Length Organizer Set 1/16 to 1/2 by 64ths PD-3

Handi-Bit Dispenser

Jobber's Length, 29pc PD-10

Mechanic's Length, 29pc PD-10

Reamers

3 Pc Step Reamer Set PD-30

Reamers, Nitro-Carb

Hole Hog Reamers with Drills PD-33

Unibit

3 Pc Set PD-29

Assortments, Cutting Tools

Carbide Burs PD-45

Assortments, Tools

Extractors

25 Piece Hex Head Spline Drive Screw Extractor Set PD-46

Screw Extractors, Sets

25 Piece Hex Head Spline Drive Screw Extractor Set PD-46

C

Countersinks

6-Flute Chatterless Countersinks PD-26

Fluteless

3 Pc Set Hex Shank PD-27

5 Pc Set, Round Shank PD-27

Round & Hex Shank PD-27

D

DRAPS, IBS Nitro Carb

NC, NF & Metric PD-34

Drill Bits

Assortments

Economy Drill Bits PD-22

IBS NITRO-X STEP TIP DRILL BIT ORGANIZER PD-3, PD-4

IBS NITRO-X STEP TIP DRILL HANDI-BIT SET PD-3

IBS Type 187 Spotweld PD-25

Jobbers Length Drill Bit Sets PD-11

Left Hand, Nitro-Carb PD-18

Letter & Number, Nitro-Carb PD-12

Mechanics Length Drill Bit Sets PD-11

Metric Nitro-Carb Drill Bit Sets PD-22

Nitro-Carb Quick-Change Hex Shank Drill Bit PD-13

Platinum Spiral Flute Step Drill Travel Trays PD-28

Reduced Shank, Nitro-Carb PD-14, PD-15

Stubby, Nitro-Carb PD-20

Nitro-Carb Left Hand

Stubby Drill Set PD-19

Ultra Point Acrylic Drill Bits PD-26

Unibit 3 Piece Set PD-29

Carbide Tipped Straight Flute Drills for Hard Steel PD-16

Extended Length PD-22

Glass & Tile PD-25

IBS Cryo-Tech HSS Nitrided

Jobber's Length PD-3, PD-4, PD-5, PD-17

IBS NITRO-X Left Hand Step Tip Drill Bits PD-17

IBS NITRO-X S&D Step Tip Drill Bits PD-4

IBS NITRO-X Step Tip Drill Bits PD-3, PD-17

IBS Type 187

Spotweld PD-25

Masonry

SDS Plus Masonry Drill Bits PD-24

SDS Plus Masonry Drill Bits

5 Pc Set PD-24

Straight Shank Masonry PD-23

Straight Shank Masonry

Drill Bits — 5 Pc Set PD-23

Nitro-Carb

Double End PD-20

Letter PD-12

Metric PD-21

Number PD-12

Quick-Change Hex Shank Drill Bits PD-13



Stubby Length PD-20

Nitro-Carb Platinum

Handi-Bit 29 Pc Mechanic's Length Drill Bit Assortment PD-10

Nitro-Carb, PLATINUM SERIES

General Info PD-8

Jobbers & Mechanic's Lengths PD-9

Mechanic's Length Reduced Shank Drills PD-14

Platinum Series Spiral Reamers PD-32

Platinum Spiral Flute Step Drills PD-28

Ultra Point Acrylic PD-26

Driver Bits

Grabit Drill-Out Broken Bolt Extractor Set PD-45

GRABIT PRO Damaged Screw Remover PD-45

E

Extractors

Bolt Extractors PD-46

Screw Extractors

Power-Outs™ Double Edged Screw Extractors PD-46

Spiral Screw Extractors PD-47

Screw Extractors, Sets

25 Piece Hex Head Spline Drive Screw Extractor Set PD-46

Grabit Drill-Out Broken Bolt Extractor Set PD-45

IBS NITRO-X Left Hand Step Tip Drill Bits & Spiral Screw Extractors Set PD-17

Power-Outs Sets PD-46

H

Handi-Bit 29 Pc Drill Bit Sets

Black PD-10

Hi-Vis PD-10

Hi-Alloy PD-25

I

IBS NITRO-X S&D Step Tip Drill Bits PD-4

N

Nitro-Carb

Stubby Length

Left Hand

Left Hand Stubby Drill Bits PD-19

Nitro-X Step Tip Mechanic's Length 51 Pc Organizer Set

1/16 to 1/2 by 64ths PD-3

R

Reamers

Nitro-Carb

Hole Hog PD-33

Step Reamers PD-30

3 Pc Set PD-30

S

Screw Extractors, Sets

Grabit Drill-Out Broken Bolt Extractor Set PD-45

IBS NITRO-X Left Hand Step Tip Drill Bits & Spiral

Screw Extractors Set PD-17

T

Technical Information

Drill Bits

Decimal Equivalent Chart For Drill Sizes PD-41

Fractional Drill Cutting Speeds in RPM PD-37

Letter Drill Cutting Speeds in RPM PD-38

Metric Drill Cutting Speeds in RPM PD-40

Number Drill Cutting Speeds in RPM PD-39

Re-sharpening Procedures PD-7

Speeds & Feeds Tables PD-35

Surface Cutting Speeds For Various Materials PD-36

Drills, Nitro-Carb

Features & Benefits PD-6

Metric Drill Cutting Speeds PD-40

Nitro Carb vs Cobalt PD-7

Drills, Nitro-Carb Platinum Series

Features & Benefits PD-8

iNES Internal Rethreading Tap PD-43

iNES Replacement Blades & Nylon Pads PD-44

NES Rethreading Tools PD-42

Nitro-Carb Spiral Reamers

Features & Benefits PD-31

Step Drills PD-28, PD-29

Threaded Rod

Tools

Deburring Tools (T03) PD-45

Grabit® Drill-Out Broken Bolt Extractor Set PD-45

Tools

Hand

iNES Internal Rethreading Tap PD-43

iNES Replacement Blades & Nylon Pads PD-44

NES Rethreading Tools PD-42

Power-Outs Sets PD-46

ThreadMate Set & External Tool PD-44

Threaded Rod

Deburring Tools (T03) PD-45

Grabit® Drill-Out Broken Bolt Extractor Set PD-45



Nitro-X Drill Bits P06

IBS NITRO-X Step Tip Drill Bits

Mechanic's Length • 3 Flats On Shank • MADE IN THE U.S.A



EXPAND HOLES • EXTREME APPLICATIONS • EXCEPTIONAL LIFE & VALUE

Nitro-X Step Tip Drill Bits have a unique **step point** for faster and cooler drilling. This innovative design combines the fast penetrating action of a reamer with all the superior features of our standard Nitro-Carb drill bits with **up to 50% faster drilling and 4X longer life.**

- **EXPAND Holes** — The **unique step tip design** easily enlarges existing holes without damaging the point that is typical with standard tip drill bits.
- **EXTREME Applications** — Ideal for hard steel, sheet metal, brass and even acrylics.
- **EXCEPTIONAL Life & Value** — The **step tip geometry reduces heat** that is generated on a larger tip, producing smaller chips and shavings for a cooler cut, reducing cutting tool wear for increase tool life.
- **Mechanics length** for a shorter, sturdier construction, **providing better control and reduced breakage.**
- **The unique step tip design** rapidly reams the hole larger as it penetrates for a faster, cooler cutting action — up to 50% faster than standard tip drill bits — saving time and money!
- **Eliminates the need to drill starter pilot holes** before making larger hole sizes.
- The **micro 135° split point provides accurate starting and self centering**, eliminating the need for a center punch or pilot hole.
- **Three flats on the shank reduce slippage for superior hold** even in hand-held operations - (3/16" and larger).
- **Gold surface treated** for added lubricity.
- **1/16" to 1/2" in 1/64" increments.**
- **MADE IN THE USA!**

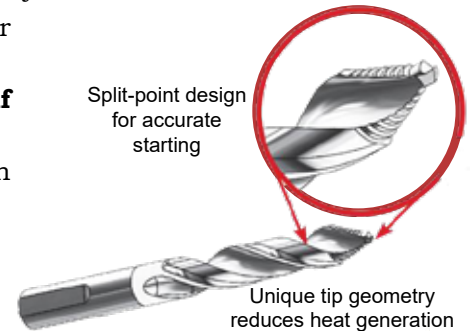

| Drill Size | IBS No. | Overall Length | Flute Length | Qty | Drill Size | IBS No. | Overall Length | Flute Length | Qty | Drill Size | IBS No. | Overall Length | Flute Length | Qty |
|------------|---------|----------------|--------------|-----|------------|---------|----------------|--------------|-----|------------|---------|----------------|--------------|-----|
| 1/16 | 18200*† | 1-7/8 | 7/8 | 6 | 7/32 | 18210 | 3-1/4 | 2 | 6 | 3/8 | 18220 | 4-1/4 | 2-11/16 | 3 |
| 5/64 | 18201*† | 2 | 1 | 6 | 15/64 | 18211 | 3-3/8 | 2-1/16 | 6 | 25/64 | 18221 | 4-5/16 | 2-3/4 | 3 |
| 3/32 | 18202*† | 2-1/4 | 1-1/4 | 6 | 1/4 | 18212 | 3-1/2 | 2 | 6 | 13/32 | 18222 | 4-3/8 | 2-13/16 | 2 |
| 7/64 | 18203*† | 2-3/8 | 1-5/16 | 6 | 17/64 | 18213 | 3-5/8 | 2-1/8 | 3 | 27/64 | 18223 | 4-7/16 | 2-7/8 | 2 |
| 1/8 | 18204† | 2-1/2 | 1-7/16 | 6 | 9/32 | 18214 | 3-3/4 | 2-1/4 | 3 | 7/16 | 18224 | 4-1/2 | 2-15/16 | 2 |
| 9/64 | 18205† | 2-5/8 | 1-9/16 | 6 | 19/64 | 18215 | 3-7/8 | 2-3/8 | 3 | 29/64 | 18225 | 4-5/8 | 3 | 2 |
| 5/32 | 18206† | 2-3/4 | 1-11/16 | 6 | 5/16 | 18216 | 4 | 2-1/2 | 3 | 15/32 | 18226 | 4-3/4 | 3-1/8 | 2 |
| 11/64 | 18207† | 2-7/8 | 1-13/16 | 6 | 21/64 | 18217 | 4-1/16 | 2-9/16 | 3 | 31/64 | 18227 | 4-7/8 | 3-1/4 | 2 |
| 3/16 | 18208 | 3 | 1-7/8 | 6 | 11/32 | 18218 | 4-1/8 | 2-5/8 | 3 | 1/2 | 18228 | 5 | 3-3/8 | 2 |
| 13/64 | 18209 | 3-1/8 | 1-15/16 | 6 | 23/64 | 18219 | 4-3/16 | 2-11/16 | 3 | | | | | |

* These bits are too small to have the Nitro-X Step Tip and have a standard 135° split point

† These bits **DO NOT** have three flats on the shank



IBS NITRO-X STEP TIP DRILL BIT ORGANIZER

| IBS No. | Description |
|---------|---|
| 16765 | 51 Pc. Nitro-X StepTip Mechanic's Length Organizer Set 1/16 to 1/2 by 64ths |



IBS NITRO-X STEP TIP DRILL HANDI-BIT SET

| IBS No. | Description |
|---------|---|
| 17466 | 13 Pc Nitro-X Step Tip Mechanic's Length Handi-Bit Set 1/8 X 1/2 by 32nds |
| 17464 | 29 Pc Nitro-X Step Tip Mechanic's Length Set 1/16 X 1/2 by 64ths |



IBS, INCORPORATED

Nitro-X Drill Bits P06

IBS NITRO-X Reduced Shank Step Tip Drill Bits



EXPAND HOLES • EXTREME APPLICATIONS • EXCEPTIONAL LIFE & VALUE

Nitro-X Reduced Shank Step Tip Drill Bits have a unique **step point** for faster and cooler drilling. This innovative design combines the fast penetrating action of a reamer with all the superior features of our standard Nitro-Carb drill bits with **up to 50% faster drilling and 4X longer life**.

- **EXPAND Holes** — The **unique step tip design** easily enlarges existing holes without damaging the point that is typical with standard tip drill bits.
- **EXTREME Applications** — Ideal for hard steel, sheet metal, brass and even acrylics.
- **EXCEPTIONAL Life & Value** — The **step tip geometry reduces heat** that is generated on a larger tip, producing smaller chips and shavings for a cooler cut, reducing cutting tool wear for increase tool life.
- **The unique step tip design** rapidly reams the hole larger as it penetrates for a faster, cooler cutting action — up to 50% faster than standard tip drill bits — saving time and money!
- The **micro 135° split point provides accurate starting and self centering**, eliminating the need for a center punch or pilot hole.
- **Three flats on the shank reduce slippage for superior hold** even in hand-held operations.
- **Gold surface treated** for added lubricity.
- **9/16" to 1" in 1/16" increments.**
- **MADE IN THE USA!**

IBS NITRO-X STEP TIP 1/2 SHANK DRILL BITS

| IBS No. | Description |
|---------|--|
| 18881 | 9/16 NITRO-X Step Tip 1/2 Shank Drill Bit |
| 18883 | 5/8 NITRO-X Step Tip 1/2 Shank Drill Bit |
| 18885 | 11/16 NITRO-X Step Tip 1/2 Shank Drill Bit |
| 18887 | 3/4 NITRO-X Step Tip 1/2 Shank Drill Bit |
| 18889 | 13/16 NITRO-X Step Tip 1/2 Shank Drill Bit |
| 18891 | 7/8 NITRO-X Step Tip 1/2 Shank Drill Bit |
| 18893 | 15/16 NITRO-X Step Tip 1/2 Shank Drill Bit |
| 18895 | 1" NITRO-X Step Tip 1/2 Shank Drill Bit |



IBS NITRO-X STEP TIP S&D 4 Pc & 8 Pc Sets

| IBS No. | Description |
|---------|--|
| 18897 | 4 Pc. Nitro-X Step Tip 1/2 Shank Drill Bit Set Sizes: 9/16", 5/8", 3/4" & 1" |
| 18899 | 8 Pc. Nitro-X Step Tip 1/2 Shank Drill Bit Set Sizes: 9/16-1 X 1/16 |

D
R
I
L
L
B
I
T
S
E
T
C



Cryo-Tech Nitrided HSS P05

IBS Cryo-Tech™ Nitrided HSS Drill Bits Jobber's Length • 135° Split Point • 3 Flats Shank MADE IN THE U.S.A.



- **Cryogenic hardening** creates a denser, more uniform grain steel for a harder, longer lasting drill bit increasing drill durability and lifespan, saving time and money.
- **A harder more durable bit that has reduced friction and wear properties as well as surface roughness** creating a cooler cutting and faster cutting drill bit that is more effective, reducing the "cost-per-hole" — outperforms cobalt in work hardening stainless steel!
- Cryogenic hardening also creates **a more uniform grain structure that also relieves stress fracturing**, making for a more durable bit that lasts 50% longer than other HSS drill bits for less breakage, less wear and increased productivity.
- **Bits are nitrided — this process diffuses nitrogen into the surface to create a case hardening** for superior tool life and exceptional corrosion resistance for a longer lasting bit that saves time and money.
- **Three flats on the shank reduce slippage for superior hold** even in hand-held operations - (3/16" and larger).

IBS CRYO-TECH NITRIDED HSS JOBBER'S LENGTH DRILL BITS

| Drill Size | IBS No. | Overall Length | Flute Length | Qty | Drill Size | IBS No. | Overall Length | Flute Length | Qty | Drill Size | IBS No. | Overall Length | Flute Length | Qty |
|------------|---------|----------------|--------------|-----|------------|---------|----------------|--------------|-----|------------|---------|----------------|--------------|-----|
| 1/16 | 16600* | 1-7/8 | 7/8 | 6 | 7/32 | 16610 | 3-3/4 | 2-1/2 | 6 | 3/8 | 16620 | 5 | 3-5/8 | 3 |
| 5/64 | 16601* | 2 | 1 | 6 | 15/64 | 16611 | 3-7/8 | 2-5/8 | 6 | 25/64 | 16621 | 5-1/8 | 3-3/4 | 3 |
| 3/32 | 16602* | 2-1/4 | 1-1/4 | 6 | 1/4 | 16612 | 4 | 2-3/4 | 6 | 13/32 | 16622 | 5-1/4 | 3-7/8 | 2 |
| 7/64 | 16603* | 2-5/8 | 1-1/2 | 6 | 17/64 | 16613 | 4-1/8 | 2-7/8 | 3 | 27/64 | 16623 | 5-3/8 | 3-15/16 | 2 |
| 1/8 | 16604* | 2-3/4 | 1-5/8 | 6 | 9/32 | 16614 | 4-1/4 | 2-15/16 | 3 | 7/16 | 16624 | 5-1/2 | 4-1/16 | 2 |
| 9/64 | 16605* | 2-7/8 | 1-3/4 | 6 | 19/64 | 16615 | 4-3/8 | 3-1/16 | 3 | 29/64 | 16625 | 5-5/8 | 4-3/16 | 2 |
| 5/32 | 16606* | 3-1/8 | 2 | 6 | 5/16 | 16616 | 4-1/2 | 3-3/16 | 3 | 15/32 | 16626 | 5-3/4 | 4-5/16 | 2 |
| 11/64 | 16607* | 3-1/4 | 2-1/8 | 6 | 21/64 | 16617 | 4-5/8 | 3-5/16 | 3 | 31/64 | 16627 | 5-7/8 | 4-3/8 | 2 |
| 3/16 | 16608 | 3-1/2 | 2-5/16 | 6 | 11/32 | 16618 | 4-3/4 | 3-7/16 | 3 | 1/2 | 16628 | 6 | 4-1/2 | 2 |
| 13/64 | 16609 | 3-5/8 | 2-7/16 | 6 | 23/64 | 16619 | 4-7/8 | 3-1/2 | 3 | | | | | |

* These bits DO NOT have three flats on the shank

IBS Cryo-Tech™ Organizer MADE IN THE U.S.A. (P15)



| IBS No. | Description |
|---------|---|
| 16764 | 51 Pc. IBS Cryo-Tech 1/16 thru 1/2 x 64ths Cryo Jobber Length Handi-Bit Index |

IBS Cryo-Tech™ Handi-Bit Set MADE IN THE U.S.A.



| IBS No. | Description |
|---------|---|
| 17437 | 29 Pc. IBS Cryo-Tech 1/16 thru 1/2 x 64ths Cryo Jobber Length Handi-Bit Index |
| 17049 | Cryo Red Handi Bit Index only (Empty) |

D R I L L B I T S E T C



IBS, INCORPORATED

Nitro-Carb Drills P02

IBS Nitro-Carb Drill Bits Super Premium High Performance Drills More Holes Per Drill! Lower Cost Per Hole!

WHAT SETS THEM APART FROM THE REST

IBS Nitro-Carb Drill Bits are manufactured with a special **high Molybdenum tool steel** for a **more consistent drill bit** with a higher than average hardness and **more resistance to wear**. The **flutes** are ground to **1/2 of industry standard tolerances**, which means **more accuracy and more consistency** in grinding operations. The flutes also feature a nitro-carburized surface to provide extra wear resistance along the cutting edge of the point.



Tighter Tolerances

DISCOVER THE NITRO-CARB DIFFERENCE

IBS Nitro Carb Drill Bits feature a **split point** which provides the drill bit with **self-centering/non-walking characteristics**, and **reduces the thrust required** to penetrate a work piece. A low temperature surface treatment relieves stress; produces a gold color and improves lubricity.

Our **Mechanic's Length Drill Bits** as well as our **1/2" Reduced Shank Drill Bits** have **3 flats on the shank**. These flats allow for a **strong positive chuck grip** of the shank and virtually **eliminate** the potential for the drill to **slip into the chuck**.

These heavy duty drill bits are recommended for use in work hardening grades of stainless steel and other tough metal drilling applications. Heavy duty construction and the nitro-carburized, hi-molybdenum tool steel means:

- **EASILY CUTS:**
Stainless Steels • Tool Steels • Exotic Steels • Standard Steels
- **Substantially longer cutting life**
The nitro-carburized flute has an increased Rockwell hardness.
- **Cuts harder materials**
The flatter point takes a smaller chip. More torque is directed to a smaller area. This allows drilling into materials with hardness of over 30 on the Rockwell "C" scale.
- **Stops drill walking**
The split point design gives accurate starting without the use of a center punch.
- **Holds tighter hole size**
The split point design is self centering. This limits the normal oversize drilling characteristics.
- **Outstanding quality appearance**
The rich amber gold color sets it apart from commodity cutting tools.
- **Runs cooler, uses less torque**
135° point takes a smaller chip resulting in less heat. Amber gold surface treatment reduces friction. The Nitro-Carb bits will substantially out-perform cobalt drill bits in work hardening stainless steel applications. This performance advantage is the result of the construction difference between the two types of bits.



Nitro-Carburized Flute



135° Split Point

D
R
I
L
L
B
I
T
S
E
T
C

Nitro-Carb Drills P02

NITRO-CARB VS. COBALT

Cobalt bits, manufactured to **Type J NAS 907 specs**, have a very thick web. A thick web provides the strength needed to limit breakage of the cobalt steel.

Nitro-Carb bits are made of special hi-moly tool steel, which is much tougher than cobalt steel. The resulting strength of the Nitro-Carb bit allows the bit to be manufactured with a considerably thinner web. (See photo A).

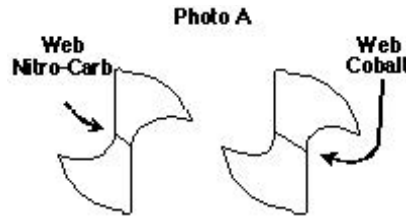

A Nitro-Carb bit with its thin web will penetrate the work hardening stainless fast enough to continually cut beneath the chip which is hardening from deformation. This means the drill bit is cutting softer steel.

The cobalt bit, with its thick web, cannot be fed at a fast enough rate to cut beneath the area which is hardening. As a result the cobalt bit is continually drilling into hardened steel.

Re-sharpening Procedure

1. SET-UP FOR POINTING

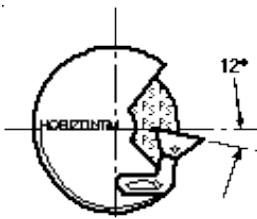

- Clamp guide block on tool rest at 67.5°.
- Set tool rest below center line.
- Dress wheel for parallel edges and true face.
- Use an 80 to 100 grit semi-friable grinding wheel.

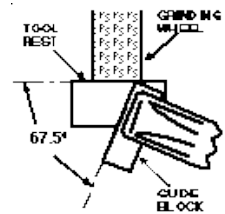

2. GRIND POINT ANGLE

Forming Primary Cutting Edge

- Pre-grind to remove all damaged edges.
- Place frill on tool rest parallel to guide block.
- Align cutting lip parallel to machine axis.
- Push into wheel.
- Repeat for second cutting edge.

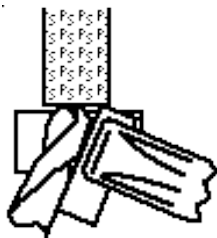

EQUAL

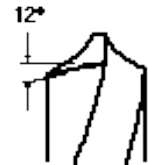

3. POINT SPLIT

Forming Secondary Cutting Edges

- Grind secondary cutting edges.
- Feed into wheel until center is reached.
- Repeat for other side.

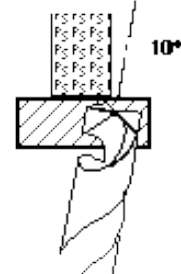
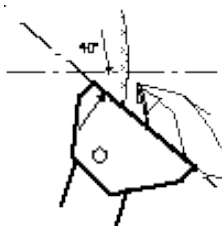
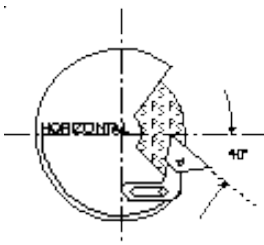

NOTE: ALL DAMAGED SECTIONS ON THE POINT AND MARGINS MUST BE GROUND AWAY PRIOR TO ANY ABOVE RESHARPENING PROCEDURE.



IBS, INCORPORATED

Nitro-Carb Drills P02

IBS Nitro-Carb Platinum Series Mechanics & Jobber's Lengths Nitro-Carb Drill Bits



"Platinum Series — The Proof is in the Performance"

D
R
I
L
L
B
I
T
S
E
T
C

- **BUILT FOR SUBSTANTIALLY LONGER CUTTING LIFE** - The Nitro-Carburized Flute has an increased Rockwell hardness providing strength without becoming brittle.
- **DESIGNED TO CUT HARDER MATERIALS** — The flatter point takes a smaller chip. More torque is directed to a smaller area. This allows drilling into materials with hardness of over 30 on the Rockwell "C scale.
- **BLACK TREATED MARGINS** - designed to produce a free flow of chips and protect the cutting edge from heat abrasion for reduced friction and wear resulting in maximum life when drilling tough materials like stainless steel.
- **STAYS SHARP** - Flute Surface Treatment improves chip removal and reduces friction so bits maintain sharpness for longer life.
- **RUNS COOL** -135° **split point** takes a smaller chip, uses less torque and minimizes heat build up for longer life.
- **ELIMINATES DRILL WALKING** - The split point design gives accurate and quick-starting without the use of a center punch - (even on round surfaces) - fewer steps saves time.
- **PRODUCES TRUE HOLES** - The split point design self-centers and holds a tighter, truer hole size. This limits oversize drilling characteristics and produces accurate holes even in handheld applications.
- **NO CHUCK SLIPPAGE** - Flats on the Mechanic's Length drill shanks (3/16" and larger) allow easy positive chuck grip for safety, and speed — great for keyless chucks!
- **UNIQUE APPEARANCE** - the bright platinum flute and black web distinguish this bit from commodity cutting tools.
- **QUALITY ASSURANCE** - Bears the IBS stamp assuring that you are using a truly unique, high quality cutting tool.
- **MADE IN THE USA!**



IBS Nitro-Carb Platinum Series Drill Bits "Platinum Series — The Proof is in the Performance"



PLATINUM SERIES NITRO CARB MECHANIC'S LENGTH DRILL BITS

| Drill Size | IBS No. | Overall Length | Flute Length | Qty | Drill Size | IBS No. | Overall Length | Flute Length | Qty | Drill Size | IBS No. | Overall Length | Flute Length | Qty |
|------------|---------|----------------|--------------|-----|------------|---------|----------------|--------------|-----|------------|---------|----------------|--------------|-----|
| 1/16 | 17400* | 1-7/8 | 7/8 | 6 | 7/32 | 17410 | 3-1/4 | 2 | 6 | 3/8 | 17420 | 4-1/4 | 2-11/16 | 3 |
| 5/64 | 17401* | 2 | 1 | 6 | 15/64 | 17411 | 3-3/8 | 2-1/16 | 6 | 25/64 | 17421 | 4-5/16 | 2-3/4 | 3 |
| 3/32 | 17402* | 2-1/4 | 1-1/4 | 6 | 1/4 | 17412 | 3-1/2 | 2 | 6 | 13/32 | 17422 | 4-3/8 | 2-13/16 | 2 |
| 7/64 | 17403* | 2-3/8 | 1-5/16 | 6 | 17/64 | 17413 | 3-5/8 | 2-1/8 | 3 | 27/64 | 17423 | 4-7/16 | 2-7/8 | 2 |
| 1/8 | 17404* | 2-1/2 | 1-7/16 | 6 | 9/32 | 17414 | 3-3/4 | 2-1/4 | 3 | 7/16 | 17424 | 4-1/2 | 2-15/16 | 2 |
| 9/64 | 17405* | 2-5/8 | 1-9/16 | 6 | 19/64 | 17415 | 3-7/8 | 2-3/8 | 3 | 29/64 | 17425 | 4-5/8 | 3 | 2 |
| 5/32 | 17406* | 2-3/4 | 1-11/16 | 6 | 5/16 | 17416 | 4 | 2-1/2 | 3 | 15/32 | 17426 | 4-3/4 | 3-1/8 | 2 |
| 11/64 | 17407* | 2-7/8 | 1-13/16 | 6 | 21/64 | 17417 | 4-1/16 | 2-9/16 | 3 | 31/64 | 17427 | 4-7/8 | 3-1/4 | 2 |
| 3/16 | 17408 | 3 | 1-7/8 | 6 | 11/32 | 17418 | 4-1/8 | 2-5/8 | 3 | 1/2 | 17428 | 5 | 3-3/8 | 2 |
| 13/64 | 17409 | 3-1/8 | 1-15/16 | 6 | 23/64 | 17419 | 4-3/16 | 2-11/16 | 3 | | | | | |

* These bits **DO NOT** have three flats on the shank



PLATINUM SERIES NITRO CARB JOBBER'S LENGTH DRILL BITS

| Drill Size | IBS No. | Overall Length | Flute Length | Qty | Drill Size | IBS No. | Overall Length | Flute Length | Qty | Drill Size | IBS No. | Overall Length | Flute Length | Qty |
|------------|---------|----------------|--------------|-----|------------|---------|----------------|--------------|-----|------------|---------|----------------|--------------|-----|
| 1/16 | 16800 | 1-7/8 | 7/8 | 6 | 7/32 | 16810 | 3-3/4 | 2-1/2 | 6 | 3/8 | 16820 | 5 | 3-5/8 | 3 |
| 5/64 | 16801 | 2 | 1 | 6 | 15/64 | 16811 | 3-7/8 | 2-5/8 | 6 | 25/64 | 16821 | 5-1/8 | 3-3/4 | 3 |
| 3/32 | 16802 | 2-1/4 | 1-1/4 | 6 | 1/4 | 16812 | 4 | 2-3/4 | 6 | 13/32 | 16822 | 5-1/4 | 3-7/8 | 2 |
| 7/64 | 16803 | 2-5/8 | 1-1/2 | 6 | 17/64 | 16813 | 4-1/8 | 2-7/8 | 3 | 27/64 | 16823 | 5-3/8 | 3-15/16 | 2 |
| 1/8 | 16804 | 2-3/4 | 1-5/8 | 6 | 9/32 | 16814 | 4-1/4 | 2-15/16 | 3 | 7/16 | 16824 | 5-1/2 | 4-1/16 | 2 |
| 9/64 | 16805 | 2-7/8 | 1-3/4 | 6 | 19/64 | 16815 | 4-3/8 | 3-1/16 | 3 | 29/64 | 16825 | 5-5/8 | 4-3/16 | 2 |
| 5/32 | 16806 | 3-1/8 | 2 | 6 | 5/16 | 16816 | 4-1/2 | 3-3/16 | 3 | 15/32 | 16826 | 5-3/4 | 4-5/16 | 2 |
| 11/64 | 16807 | 3-1/4 | 2-1/8 | 6 | 21/64 | 16817 | 4-5/8 | 3-5/16 | 3 | 31/64 | 16827 | 5-7/8 | 4-3/8 | 2 |
| 3/16 | 16808 | 3-1/2 | 2-5/16 | 6 | 11/32 | 16818 | 4-3/4 | 3-7/16 | 3 | 1/2 | 16828 | 6 | 4-1/2 | 2 |
| 13/64 | 16809 | 3-5/8 | 2-7/16 | 6 | 23/64 | 16819 | 4-7/8 | 3-1/2 | 3 | | | | | |

D R I L L B I T S E T C



IBS, INCORPORATED

Nitro-Carb Drill Bit Sets P15

Handi-Bit 29 PcDrill Bit Sets Available in Black and Hi-Visibility Indexes



D
R
I
L
L

B
I
T
S

E
T
C

Our 29 pc clip-on drill index is ideal for use both in the shop or at the job site. Made from high impact plastic, the Handi-Bit canister has a molded side hook that clips on to a tool caddy, utility belt, tool bucket, or ladder. Eliminate wasted time searching for the correct drill bit - 29 different sizes are in hands reach. With a screw-on plastic hex shaped cover, drill bits will remain secure and protected. Available in **Mechanics, Jobbers and Left Handed** styles.

- Contains drill bits from 1/16" to 1/2" by 64ths.
- Screw-on hex-shaped cover protects & contains drill bits.
- Water-resistant, great for outdoor job sites.
- Constructed of high-impact, break resistant plastic.
- Available in Black and Hi-Visibility Yellow Handi-Bit Indexes

BLACK DRILL INDEX

HI-VISIBILITY DRILL INDEX

| IBS No. | Description | Qty | IBS No. | Description | Qty |
|---------|--------------------------|-----|---------|---------------------------|-----|
| 17435 | Mechanic's Length | 1 | 17460 | Mechanic's Length | 1 |
| 17438 | Jobber's Length | 1 | 17461 | Jobber's Length | 1 |
| 17439 | Left Hand Jobbers Length | 1 | 17462 | Left Hand Jobber's Length | 1 |

IBS, INCORPORATED

Nitro-Carb Drill Assortments P15



Nitro-Carb Drill Bit Sets Jobber's Length



JOBBER'S LENGTH DRILL BIT SETS - INDEX

| IBS No. | Description |
|---------|---|
| 16756 | 13 Pc. Jobbers Length Fractional Drill Set Sizes 1/16" to 1/4" by 64ths. Complete with index. |
| 16755 | 15 Pc. Jobber's Length Drill Set Sizes 1/16" to 1/2" by 32nds. Packaged in a 29 Pc. index for expansion to 64ths sizes |
| 16759 | 15 Pc. Jobbers Length Drill Set Sizes 1/16" to 1/2" by 32nds. Complete with 32nds index |
| 16757 | 21 Pc. Jobber's Length Drill Set Sizes 1/16" to 3/8" by 64ths Complete with index |
| 16760 | 29 Pc. Jobber's Length Drill Set Sizes 1/16" to 1/2" by 64ths. Complete with index. |
| 16763 | 115 Pc. Fractional, Letter & Number Drill Set Contains Platinum Series and Nitro-Carb Drill Bits Letter Drills A to Z (NC) Number Drills #1 through #60 (NC) Fractional drills 1/16" to 1/2" by 64ths (Platinum) |



JOBBER'S LENGTH DRILL BIT SET - ORGANIZER

| IBS No. | Description |
|---------|---|
| 16762 | 51 Pc Jobbers Length Drill Set 29 of the most popular drill bit sizes. Contains 51 Platinum drill bits Sizes 1/16" to 1/2" by 64ths. Complete with 3 drawer organizer See Chart for sizes and quantities. |

Nitro-Carb Drill Bit Sets Mechanic's Length



MECHANIC'S LENGTH DRILL BIT SETS - INDEX

| IBS No. | Description |
|---------|---|
| 17433 | 13 Pc. Mechanic's Length Drill Set Sizes 1/16" to 1/4" by 64ths. Complete with index |
| 17432 | 15 Pc. Mechanic's Length Drill Set Sizes 1/16" to 1/2" by 32nds. Packaged in a 29 Pc. index for expansion to 64ths sizes |
| 17434 | 21 Pc. Mechanic's Length Drill Set Sizes 1/16" to 3/8" by 64ths. Complete with index |
| 17431 | 29 Pc. Mechanic's Length Drill Set Sizes 1/16" to 1/2" by 64ths Complete with index. |



MECHANIC'S LENGTH DRILL BIT SET - ORGANIZER

| IBS No. | Description |
|---------|--|
| 17430 | 51 Pc Mechanic's Length Drill Set 29 of the most popular drill bit sizes. Contains 51 Platinum drill bits Sizes 1/16" to 1/2" by 64ths. Complete with 3 drawer organizer See Chart for sizes and quantities. |

16762 & 17430 BIT SIZES & QUANTITIES

| Size | Qty. | Size | Qty. | Size | Qty. | Size | Qty. |
|-------|------|-------|------|-------|------|-------|------|
| 1/16 | 3 | 3/16 | 4 | 5/16 | 1 | 7/16 | 1 |
| 5/64 | 3 | 13/64 | 1 | 21/64 | 1 | 29/64 | 1 |
| 3/32 | 3 | 7/32 | 1 | 11/32 | 1 | 15/32 | 1 |
| 7/64 | 3 | 15/64 | 1 | 23/64 | 1 | 31/64 | 1 |
| 1/8 | 5 | 1/4 | 3 | 3/8 | 1 | 1/2 | 1 |
| 9/64 | 3 | 17/64 | 1 | 25/64 | 1 | | |
| 5/32 | 3 | 9/32 | 1 | 13/32 | 1 | | |
| 11/64 | 2 | 19/64 | 1 | 27/64 | 1 | | |

D R I L L B I T S E T C



IBS, INCORPORATED

Nitro-Carb Drills P02

Nitro-Carb Number Drills

Sizes #1 — #52 are 135° split point.
Sizes #53 — #80 are non-split point.
Sizes #61 — #80 are high speed steel.



NITRO CARB NUMBER DRILL BITS

| Drill Size | IBS No. | Drill Size | IBS No. | Drill Size | IBS No. |
|------------|---------|------------|---------|------------|---------|
| #1 | 16080 | #28 | 16107 | #55 | 15927 |
| #2 | 16081 | #29 | 16108 | #56 | 15928 |
| #3 | 16082 | #30 | 16109 | #57 | 15929 |
| #4 | 16083 | #31 | 16110 | #58 | 15930 |
| #5 | 16084 | #32 | 16111 | #59 | 15931 |
| #6 | 16085 | #33 | 16112 | #60 | 15932 |
| #7 | 16086 | #34 | 16113 | #61 | 16715 |
| #8 | 16087 | #35 | 16114 | #62 | 16716 |
| #9 | 16088 | #36 | 16115 | #63 | 16717 |
| #10 | 16089 | #37 | 16116 | #64 | 16718 |
| #11 | 16090 | #38 | 16117 | #65 | 16719 |
| #12 | 16091 | #39 | 16118 | #66 | 16720 |
| #13 | 16092 | #40 | 16119 | #67 | 16721 |
| #14 | 16093 | #41 | 16120 | #68 | 16722 |
| #15 | 16094 | #42 | 16121 | #69 | 16723 |
| #16 | 16095 | #43 | 16122 | #70 | 16724 |
| #17 | 16096 | #44 | 16123 | #71 | 16725 |
| #18 | 16097 | #45 | 16124 | #72 | 16726 |
| #19 | 16098 | #46 | 16125 | #73 | 16727 |
| #20 | 16099 | #47 | 16126 | #74 | 16728 |
| #21 | 16100 | #48 | 16127 | #75 | 16729 |
| #22 | 16101 | #49 | 16128 | #76 | 16730 |
| #23 | 16102 | #50 | 16129 | #77 | 16731 |
| #24 | 16103 | #51 | 16130 | #78 | 16732 |
| #25 | 16104 | #52 | 16131 | #79 | 16733 |
| #26 | 16105 | #53 | 16132 | #80 | 16734 |
| #27 | 16106 | #54 | 15926 | | |

Sold in quantities of (1)

Nitro-Carb Letter Drills



NITRO CARB LETTER DRILL BITS A - Z

| Drill Size | IBS No. | Drill Size | IBS No. |
|------------|---------|------------|---------|
| A | 16135 | N | 16148 |
| B | 16136 | O | 16149 |
| C | 16137 | P | 16150 |
| D | 16138 | Q | 16151 |
| E | 16139 | R | 16152 |
| F | 16140 | S | 16153 |
| G | 16141 | T | 16154 |
| H | 16142 | U | 16155 |
| I | 16143 | V | 16156 |
| J | 16144 | W | 16157 |
| K | 16145 | X | 16158 |
| L | 16146 | Y | 16159 |
| M | 16147 | Z | 16160 |

Sold in quantities of (1)

Letter & Number Drill Bit Sets (P15)



LETTER & NUMBER DRILL BIT SETS - INDEX

| IBS No. | Description |
|---------|--|
| 16703 | 60 Pc. Jobber's Length Number Drill Set Sizes #1 through #60. Complete with Index. |
| 16704 | 26 Pc. Jobber's Length Letter Drill Set Sizes A through Z. Complete with index. |
| 16713 | 60 Pc. Jobber's Length Number Drill Set Sizes #1 through #60. Complete with 5 drawer organizer. |
| 16714 | 26 Pc. Jobber's Length Letter Drill Set Sizes A through Z. Complete with 3 drawer organizer. |

DRILL BITS ETC



Nitro-Carb Quick-Change Hex Shank Drill Bits (P21)



A new version of our superior Nitro-Carb Mechanics Length Drill Bits featuring the convenience of a quick change hex shank.

- One piece machined shank (bits larger than 1/4") encounter more torque to withstand. Competitor bits have cast shanks that do not stand up to the force and constant use.
- All metal, welded shank design (bits 1/4" and smaller) — competitor bits have cast shanks that do not stand up to the force and constant use.
- Special Hi-Molybdenum tool steel.
- 135° split point for fast penetration and accurate starting without center punch.
- Body and clearance are treated for maximum lubricity.
- Especially designed for hand held drills.
- Recommended for use in hardening grades of stainless steel and other hard metal drill applications.
- Quick release eases changing of cutting tools

| Drill Size | IBS No. | Drill Size | IBS No. |
|------------|---------|------------|---------|
| 1/16 | 15400 | 5/16 | 15416 |
| 3/32 | 15402 | 11/32 | 15418 |
| 1/8 | 15404 | 3/8 | 15420 |
| 5/32 | 15406 | 13/32 | 15422 |
| 3/16 | 15408 | 7/16 | 15424 |
| 7/32 | 15410 | 15/32 | 15426 |
| 1/4 | 15412 | 1/2 | 15428 |
| 9/32 | 15414 | | |

Sold in quantities of (1)

Nitro-Carb Quick-Change Hex Shank Drill Bit Sets (P15)



15429, 15430



15431



15432

| IBS No. | Description |
|---------|---|
| 15429 | 7 Pc. Nitro-Carb Mech Length Drill Bit Set - Pouch. Sizes 1/16 to 1/4 by 32nds |
| 15430 | 7 Pc. Nitro-Carb Mech Length Drill Bit Set - Pouch. Sizes 1/8 to 1/2 by 16ths |
| 15431 | 16 Pc. Nitro-Carb Mech Length Drill Bit Set - Pouch. Sizes 1/16 to 1/2 by 32nds |
| 15432 | 12 Pc. Nitro-Carb Mech Length Drill Bit Set - Hard Case. Sizes 1/16 to 1/2 by 32nds |

Quick Release Drill Bit & Insert Assortment
IBS No. 744R • 22 Items • 28 Pcs
 Packaged in a locking steel drawer for easy storage and organization

IBS, Inc.
SPECIALTY PRODUCTS FOR MAINTENANCE & REPAIR
 INDUSTRIALDRILL.COM • P.O. BOX 478-1906

Quick Release Drill Bit and Power Bit Assortment
Assortment No. 744R

* ITEMS FOR EXPANSION

| | | | |
|---|--|--|--|
| 15404 1/8 HEX SHANK DRILL <small>*15400 1/16 HEX SHANK DRILL *15402 3/32 HEX SHANK DRILL</small> | 15406 5/32 MECH LGTH NITRO CARB QUICK RELEASE HEX SHANK DRILL | 15408 3/16 MECH LGTH NITRO CARB QUICK RELEASE HEX SHANK DRILL | 15410 7/32 MECH LGTH NITRO CARB QUICK RELEASE HEX SHANK DRILL |
| 15412 1/4 MECH LGTH NITRO CARB QUICK RELEASE HEX SHANK DRILL | 15414 9/32 MECH LGTH NITRO CARB QUICK RELEASE HEX SHANK DRILL | 15416 5/16 MECH LGTH NITRO CARB QUICK RELEASE HEX SHANK DRILL | |
| 15418 11/32 MECH LGTH NITRO CARB QUICK RELEASE HEX SHANK DRILL | 15420 3/8 MECH LGTH NITRO CARB QUICK RELEASE HEX SHANK DRILL | <small>*15422 13/32 HEX SHANK DRILL *15424 7/16 HEX SHANK DRILL *15426 15/32 HEX SHANK DRILL *15428 1/2 HEX SHANK DRILL</small> | |
| 250-PB11 #1 PHIL X 1-15/16 POWER BIT | 250-PB12 #2 PHIL X 1-15/16 POWER BIT | 250-PB13 #3 PHIL X 1-15/16 POWER BIT | MSH1/4 1/4 NUT DRIVER |
| 250-PB31 #1 PHIL X 3-1/2 POWER BIT | 250-PB32 #2 PHIL X 3-1/2 POWER BIT | 250-PB33 #3 PHIL X 3-1/2 POWER BIT | MSH5/16 5/16 NUT DRIVER |
| 250-R11 #1 SQ. DRIVE X 1-15/16 POWER BIT | 250-R12 #2 SQ. DRIVE X 1-15/16 POWER BIT | 250-R13 #3 SQ. DRIVE X 1-15/16 POWER BIT | MSH3/8 3/8 NUT DRIVER |

D R I L L B I T S E T C



IBS, INCORPORATED

Nitro-Carb Drills P02

D
R
I
L
L
B
I
T
S
E
T
C

1/2" & 3/8" Reduced Shank Drill Bits (P03)

- Hi-Molybdenum tool steel.
- Heavy duty construction.
- 135° split point - Sizes larger than 1" have 118° split point.
- 3 flats on shank (on 1/2" Reduced Shank Only) individually tubed and insure positive chucking without slippage
- Gold surface treated body and clearance for maximum lubricity.
- 6" Overall Length.



3/8" REDUCED SHANK DRILL BITS

| Drill Size | IBS No. | Qty. | Drill Size | IBS No. | Qty. |
|------------|---------|------|------------|---------|------|
| 25/64 | 16870 | 1 | 29/64 | 16874 | 1 |
| 13/32 | 16871 | 1 | 15/32 | 16875 | 1 |
| 27/64 | 16872 | 1 | 31/64 | 16876 | 1 |
| 7/16 | 16873 | 1 | 1/2 | 16877 | 1 |



1/2" REDUCED SHANK DRILL BITS

| Drill Size | IBS No. | Qty. | Drill Size | IBS No. | Qty. |
|------------|---------|------|------------|---------|------|
| 33/64 | 16833 | 1 | 13/16 | 16852 | 1 |
| 17/32 | 16834 | 1 | 53/64 | 16853 | 1 |
| 35/64 | 16835 | 1 | 27/32 | 16854 | 1 |
| 9/16 | 16836 | 1 | 55/64 | 16855 | 1 |
| 37/64 | 16837 | 1 | 7/8 | 16856 | 1 |
| 19/32 | 16838 | 1 | 57/64 | 16857 | 1 |
| 39/64 | 16839 | 1 | 29/32 | 16858 | 1 |
| 5/8 | 16840 | 1 | 59/64 | 16859 | 1 |
| 41/64 | 16841 | 1 | 15/16 | 16860 | 1 |
| 21/32 | 16842 | 1 | 61/64 | 16861 | 1 |
| 43/64 | 16843 | 1 | 31/32 | 16862 | 1 |
| 11/16 | 16844 | 1 | 63/64 | 16863 | 1 |
| 45/64 | 16845 | 1 | 1 | 16864 | 1 |
| 23/32 | 16846 | 1 | 1-1/16 | 16865 | 1 |
| 47/64 | 16847 | 1 | 1-1/8 | 16866 | 1 |
| 3/4 | 16848 | 1 | 1-1/4 | 16867 | 1 |
| 49/64 | 16849 | 1 | 1-3/8 | 16868 | 1 |
| 25/32 | 16850 | 1 | 1-1/2 | 16869 | 1 |
| 51/64 | 16851 | 1 | | | |

1/2" Mechanic's Length Platinum Series Reduced Shank Drills (P03)

- Hi-Molybdenum tool steel.
- Heavy duty construction.
- 135° split point - Sizes larger than 1" have 118° split point.
- Black treated margins provides a free flow of chips and protects the cutting edge from heat abrasion so drills last longer when drilling tough materials like stainless steel.
- 3 flats on shank individually tubed and insure positive chucking without slippage.
- Designed for use in work hardening grades of stainless steel and other hard metal drilling applications.
- 5" Overall Length.



1/2" REDUCED SHANK DRILL BITS

| Drill Size | IBS No. | Qty. | Drill Size | IBS No. | Qty. |
|------------|---------|------|------------|---------|------|
| 9/16 | 16881 | 1 | 13/16 | 16889 | 1 |
| 5/8 | 16883 | 1 | 7/8 | 16891 | 1 |
| 11/16 | 16885 | 1 | 15/16 | 16893 | 1 |
| 3/4 | 16887 | 1 | 1 | 16895 | 1 |

Reduced Shank Nitro-Carb Drill Bit Sets(P15)



REDUCED SHANK DRILL BIT SETS - CASE

| IBS No. | Description |
|---------|---|
| 16897 | 4 Pc. Reduced Shank Mechanics Length PLATINUM SERIES 9/16, 5/8, 3/4, 1" Complete with sturdy storage case |
| 16898 | 4 Pc. Jobber's Length Nitro-Carb Reduced Shank Drill Set 9/16, 5/8, 3/4, 1" Complete with sturdy storage case |



Reduced Shank Nitro-Carb Drill Sets (P15)



3/8 REDUCED SHANK DRILL BIT SETS - INDEX

| IBS No. | Description |
|---------|--|
| 16706 | 29 Pc. Jobber's Length Nitro-Carb Reduced Shank Drill Set 1/16" to 1/2" by 64ths 3/8" shank on drill sizes larger than 3/8" Complete with metal index |
| 16707 | 15 Pc. Jobber's Length Reduced Shank Starter Set 1/16" to 1/2" by 32nds. 3/8" shank on drill sizes larger than 3/8" Complete with 29 pc index for expansion NOTE: Contains same drills as 16705 - different index |
| 16705 | 15 Pc. Jobber's Length Reduced Shank Starter Set 1/16" to 1/2" by 32nds. 3/8" shank on drill sizes larger than 3/8" Complete with 29 pc index for expansion NOTE: Contains same drills as 16707 - different index |



1/2 REDUCED SHANK DRILL BIT SETS - INDEX

| IBS No. | Description |
|---------|---|
| 16761 | 8 Pc. Jobber's Length Reduced Shank Drill Set 9/16, 5/8, 11/16, 3/4, 13/16, 7/8, 15/16, 1" Complete with metal index |
| 16899 | 8 Pc. Mechanic's Length Reduced Shank Drill Set 9/16, 5/8, 11/16, 3/4, 13/16, 7/8, 15/16, 1" Complete with metal index |



REDUCED SHANK DRILL BIT SETS - STAND

| IBS No. | Description |
|---------|--|
| 16709 | 4 Pc. Jobber's Length Reduced Shank Drill Set 9/16, 5/8, 11/16, 3/4" Complete with metal stand |
| 16710 | 33 Pc. Jobber's Length Reduced Shank Drill Set 1/2, 33/64, 17/32, 35/64, 9/16, 37/64, 19/32, 39/64, 5/8, 41/64, 21/32, 43/64, 11/16, 45/64, 23/32, 47/64, 3/4", 49/64, 25/32, 51/64, 13/16, 53/64, 27/32, 55/64, 7/8, 57/64, 29/32, 59/64, 15/16, 61/64, 31/32, 63/64, 1" Complete with metal stand |

D R I L L B I T S E T C



IBS, INCORPORATED

Nitro-Carb Drills P02

Carbide Tipped Straight Flute Drills for Hard Steel (P20)



When other drill bits can't cut it, turn to the bit designed for hardened steels and drilling out broken items such as studs and taps.

- Straight-flute drill bits are stronger than spiral-flute drill bits and resist breaking when drilling into hard and abrasive materials, such as hardened steels with a Rockwell hardness of 48 to 65 HRC.
- The bits provide free cutting action, generate minimal heat during drilling and leave a smooth finish on the hole without requiring a reaming pass
- Straight flutes help with chip evacuation in horizontal drilling applications.
- Carbide-tipped drill bits have carbide cutting edges that provide excellent hardness, wear resistance, and heat resistance.
- The bit's body is made from a material that absorbs more vibration and shock than carbide, so they are less rigid and less likely to break than solid carbide drill bits.

| IBS No. | Diameter (in.) | Shank Diameter (in) | Overall Length (in) | Qty |
|---------|---|---------------------|---------------------|-----|
| 16173 | 3/16 | 3/16 | 3 | 1 |
| 16175 | 1/4 | 1/4 | 4 | 1 |
| 16178 | 5/16 | 1/4 | 4 | 1 |
| 16180 | 3/8 | 3/8 | 6 | 1 |
| 16183 | 1/2 | 1/2 | 6 | 1 |
| 17463 | 5 Pc Carbide Tipped Straight Flute Drill Set for Hard Steel (P15) | | | 1 |
| 834R | 5 Pc Carbide Tipped Straight Flute Drill Set for Hard Steel (P15) | | | |



5 Pc Carbide Tipped Straight Flute Drill Set

IBS No. 17463 • 5 Items • 5 Pcs

Includes sizes

3/16, 1/4, 5/16, 3/8 & 1/2

Packaged in a Folding Pouch for Easy Storage and Organization

- Pouch holds up to 7 drills (IBS No. 17035).
- Sturdy belt clip for convenience.
- **Pouch Dimensions:** Closed 3-1/2" X 6-1/2"
Open: 3-1/2" X 13"

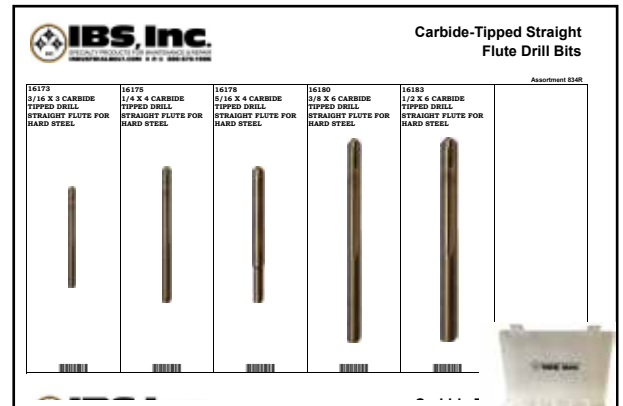

5 Pc Carbide Tipped Straight Flute Drill Set

IBS No. 834R • 5 Items • 5 Pcs

Includes sizes

3/16, 1/4, 5/16, 3/8 & 1/2"

Packaged in Plastic Travel Tray for Easy Storage & Organization

D
R
I
L
L
B
I
T
S
E
T
C

Left Hand Drill Bits P16

IBS NITRO-X Left Hand Step Tip Drill Bits

Mechanic's Length • 3 Flats On Shank • MADE IN THE U.S.A



EXPAND HOLES • EXTREME APPLICATIONS • EXCEPTIONAL LIFE & VALUE

Nitro-X Step Tip Drill Bits have a unique **step point** for faster and cooler drilling. This innovative design combines the fast penetrating action of a reamer with all the superior features of our standard Nitro-Carb drill bits with **up to 50% faster drilling and 4X longer life.**

- **EXPAND Holes** — The **unique step tip design** easily enlarges existing holes without damaging the point that is typical with standard tip drill bits.
- **EXTREME Applications** — Ideal for hard steel, sheet metal, brass and even acrylics.
- **EXCEPTIONAL Life & Value** — The **step tip geometry reduces heat** that is generated on a larger tip, producing smaller chips and shavings for a cooler cut, reducing cutting tool wear for increase tool life.
- **Mechanics length** for a shorter, sturdier construction, **providing better control and reduced breakage.**
- **The unique step tip design** rapidly reams the hole larger as it penetrates for a faster, cooler cutting action — up to 50% faster than standard tip drill bits — saving time and money!
- **Eliminates the need to drill starter pilot holes** before making larger hole sizes.
- The **micro 135° split point provides accurate starting and self centering**, eliminating the need for a center punch or pilot hole.
- **Three flats on the shank reduce slippage for superior hold** even in hand-held operations - (3/16" and larger).
- **Gold surface treated** for added lubricity.
- **1/8" to 3/8" in 1/16" increments.**
- **MADE IN THE USA!**
- Ideal for drilling broken studs.
- Need for screw and bolt extractor may be eliminated.

| Drill Size | IBS No. | Qty. |
|------------|---------|------|
| 1/8 | 18434 | 3 |
| 3/16 | 18438 | 3 |
| 1/4 | 18442 | 3 |
| 5/16 | 18446 | 3 |
| 3/8 | 18450 | 3 |

IBS NITRO-X Left Hand Step Tip Drill Bits & Spiral Screw Extractors Set



| IBS No. | Description |
|---------|---|
| 16712 | 10 Pc. Nitro-X Left Hand Drill Bit and Spiral Screw Extractor Set Drills: 3/32 thru 5/16 x 1/16ths. Spiral Screw Extractors: #1 thru #5 |



IBS, INCORPORATED

Nitro-Carb Drill Bits P02

Left Hand Drill Bits (P16)

- Nitro-Carburized Hi-Molybdenum tool steel.
- Gold surface treated for maximum lubricity.
- Self centering 135° split point for fast penetration & accurate starting without a center punch.
- Precision ground point, flutes and body, clearance, and drill diameter provide the ultimate in accuracy and performance.
- Ideal for drilling broken studs.
- Need for screw and bolt extractor may be eliminated.



| Drill Size | IBS No. | Qty. | Drill Size | IBS No. | Qty. | Drill Size | IBS No. | Qty. | Drill Size | IBS No. | Qty. |
|------------|---------|------|------------|---------|------|------------|---------|------|------------|---------|------|
| 1/16 | 15940 | 3 | 3/16 | 15948 | 2 | 5/16 | 15957 | 1 | 7/16 | 15965 | 1 |
| 5/64 | 15941 | 3 | 13/64 | 15949 | 2 | 21/64 | 15958 | 1 | 29/64 | 15966 | 1 |
| 3/32 | 15942 | 3 | 7/32 | 15950 | 2 | 11/32 | 15959 | 1 | 15/32 | 15967 | 1 |
| 7/64 | 15943 | 3 | 15/64 | 15951 | 2 | 23/64 | 15960 | 1 | 31/64 | 15968 | 1 |
| 1/8 | 15944 | 3 | 1/4 | 15953 | 2 | 3/8 | 15961 | 1 | 1/2 | 15969 | 1 |
| 9/64 | 15945 | 3 | 17/64 | 15954 | 1 | 25/64 | 15962 | 1 | | | |
| 5/32 | 15946 | 3 | 9/32 | 15955 | 1 | 13/32 | 15963 | 1 | | | |
| 11/64 | 15947 | 2 | 19/64 | 15956 | 1 | 27/64 | 15964 | 1 | | | |

Left Hand Drill Bit Sets (P15)



LEFT HAND DRILL BIT SETS - INDEX

| IBS No. | Description |
|---------|---|
| 15970 | 8 Pc. Left Hand Nitro Carb Drill Bit Starter Set 1/16 thru 1/2 x 1/16ths. Packaged in a 15 pc index for expansion |
| 15971 | 29 Pc. Left Hand Nitro Carb Drill Bit Set 1/16 thru 1/2 x 64ths. Packaged in a 29 Pc Index |
| 17429 | 8 Pc. Left Hand Nitro Carb Drill Bit Set 1/16 thru 1/2 x 16ths. Packaged in a 29 Pc Handi-Bit Index for expansion |
| 17439 | 29 Pc. Left Hand Nitro Carb Drill Bit Set 1/16 thru 1/2 x 64ths. Packaged in a 29 Pc Handi-Bit Index |

D
R
I
L
L
B
I
T
S
E
T
C

Nitro-Carb Drill Bits P02

Left Hand Stubby Drill Bits

- **PERFECT FOR REMOVING BROKEN BOLTS AND STUDS** – The shorter length makes for a stronger, more stable drill and the left hand flute design assists with drilling out broken bolts and studs without tightening further - actually loosening and backing out the broken bolt or stud – saving time and money on costly repairs.
- **Nitro-Carburized** Hi-Molybdenum tool steel.
- **Gold surface treated** for maximum lubricity.
- **Self centering 135° split point** for fast penetration & accurate starting without a center punch.
- **Precision ground point, flutes and body**, clearance, and drill diameter provide the ultimate in accuracy and performance.
- **NO CHUCK SLIPPAGE** — Flats on the Stubby Length drill shanks allow easy positive chuck grip for safety and speed — great for keyless chucks!
- Ideal for removing broken studs.
- Need for screw and bolt extractor may be eliminated.
- **MADE IN THE USA!**



Nitro-Carb Left Hand Stubby Drill Set (P15)

| Drill Size | IBS No. | Qty. | Drill Size | IBS No. | Qty. |
|------------|---------|------|------------|---------|------|
| 1/16 | 18400 | 3 | 9/32 | 18414 | 1 |
| 5/64 | 18401 | 3 | 5/16 | 18416 | 1 |
| 3/32 | 18402 | 3 | 11/32 | 18418 | 1 |
| 1/8 | 18404 | 3 | 3/8 | 18420 | 1 |
| 5/32 | 18406 | 3 | 13/32 | 18422 | 1 |
| 3/16 | 18408 | 2 | 7/16 | 18424 | 1 |
| 7/32 | 18410 | 2 | 15/32 | 18426 | 1 |
| 1/4 | 18412 | 2 | 1/2 | 18428 | 1 |



| IBS No. | Description |
|---------|---|
| 16702 | 15 Pc. Nitro-Carb Left Hand Stubby Drill Index Set 1/16 thru 1/2 x 64ths. Complete with metal index |

Power Out Extractor & Stubby Left Hand Drill Bit Travel Tray

IBS No. 818R • 10 Items • 10 Pcs • (P15)

Packaged in an adjustable compartment small plastic travel tray for easy storage and organization

Power-Out Extractor & Stubby Left Hand Nitro Carb Drill Bit

Assortment 818R

| | | | | | |
|--|--|--|--|--|--|
| <p>139501 #1 POWER-OUT DBL EDGED SCREW EXTRACTOR</p> | <p>139502 #2 POWER-OUT DBL EDGED SCREW EXTRACTOR</p> | <p>139503 #3 POWER-OUT DBL EDGED SCREW EXTRACTOR</p> | <p>139504 #4 POWER-OUT DBL EDGED SCREW EXTRACTOR</p> | <p>139505 #5 POWER-OUT DBL EDGED SCREW EXTRACTOR</p> | |
| <p>18406 5/32 STUBBY LEFT HAND NITRO CARB DRILL</p> | <p>18412 1/4 STUBBY LEFT HAND NITRO CARB DRILL</p> | <p>18416 5/16 STUBBY LEFT HAND NITRO CARB DRILL</p> | <p>18424 7/16 STUBBY LEFT HAND NITRO CARB DRILL</p> | <p>18428 1/2 STUBBY LEFT HAND NITRO CARB DRILL</p> | |

DRILL BITS ETC



IBS, INCORPORATED

Nitro-Carb Drill Bits P02

Nitro-Carb Double End Drills (P20)



- Self centering 135° split point.
- Nitro-Carburized Hi-Molybdenum tool steel.
- 2 drills in one means twice the holes per drill and lower costs per hole.
- Ideal for pop rivet applications, truck and auto bodies and any thin sheet metal applications.

| Drill Size | IBS No. | Qty. | Drill Size | IBS No. | Qty. |
|------------|---------|------|------------|---------|------|
| 1/8 | 15909 | 6 | 1/4 | 15915 | 6 |
| 5/32 | 15910 | 6 | #11 | 15917 | 6 |
| 3/16 | 15911 | 6 | #20 | 15918 | 6 |
| 7/32 | 15912 | 6 | #30 | 15919 | 6 |

Nitro-Carb Double End Drill Travel Tray (P15)

IBS No. 17442 • 6 Items • 12 Pcs

Packaged in an adjustable compartment small plastic travel tray for easy storage and organization



Stubby Drill Bits



- Hi-Molybdenum tool steel.
- Heavy duty construction.
- 135° split point, no center punch needed — will not walk.
- Recommended for work hardening grades of stainless steel and other hard metal drilling applications.
- Gold surface treated body and clearance for maximum lubricity.
- Short length of drill makes this an especially rigid drill for greater drilling accuracy.
- Less stress due to shorter length and less breakage.
- Drill is designed for ease of penetration and to facilitate chip removal in tough, hard materials.

| Drill Size | IBS No. | Qty. | Drill Size | IBS No. | Qty. | Drill Size | IBS No. | Qty. | Drill Size | IBS No. | Qty. |
|------------|---------|------|------------|---------|------|------------|---------|------|------------|---------|------|
| 1/16 | 17800 | 6 | 3/16 | 17808 | 6 | 5/16 | 17816 | 3 | 7/16 | 17824 | 2 |
| 5/64 | 17801 | 6 | 13/64 | 17809 | 6 | 21/64 | 17817 | 3 | 29/64 | 17825 | 2 |
| 3/32 | 17802 | 6 | 7/32 | 17810 | 6 | 11/32 | 17818 | 3 | 15/32 | 17826 | 2 |
| 7/64 | 17803 | 6 | 15/64 | 17811 | 6 | 23/64 | 17819 | 3 | 31/64 | 17827 | 2 |
| 1/8 | 17804 | 6 | 1/4 | 17812 | 3 | 3/8 | 17820 | 3 | 1/2 | 17828 | 2 |
| 9/64 | 17805 | 6 | 17/64 | 17813 | 3 | 25/64 | 17821 | 2 | | | |
| 5/32 | 17806 | 6 | 9/32 | 17814 | 3 | 13/32 | 17822 | 2 | | | |
| 11/64 | 17807 | 6 | 19/64 | 17815 | 3 | 27/64 | 17823 | 2 | | | |

Stubby Nitro-Carb Drill Set (P15)



| IBS No. | Description |
|---------|---|
| 16708 | 29 Pc. Nitro-Carb Stubby Drill Bit Set 1/16 thru 1/2 x 64ths. Complete with metal index |
| 16711 | 15 Pc. Nitro-Carb Stubby Drill Bit Set 1/16 thru 1/2 x 32nds. Complete with metal index |



Nitro-Carb Drill Bits P02

Metric Nitro-Carb Drill Bits (P02)

- Nitro-Carburized Hi-Molybdenum tool steel.
- Gold surface treated for maximum lubricity.
- Self centering 135° split point for fast penetration & accurate starting without a center punch.
- Precision ground point, flutes and body, clearance, and drill diameter provide the ultimate in accuracy and performance.

| Drill Size | IBS No. | Qty. | Drill Size | IBS No. | Qty. | Drill Size | IBS No. | Qty. | Drill Size | IBS No. | Qty. |
|------------|---------|------|------------|---------|------|------------|---------|------|------------|---------|------|
| .7 | 17830 | 1 | 3.0 | 17864 | 1 | 6.4 | 17898 | 1 | 9.8 | 17932 | 1 |
| .8 | 17831 | 1 | 3.1 | 17865 | 1 | 6.5 | 17899 | 1 | 9.9 | 17933 | 1 |
| .85 | 17832 | 1 | 3.2 | 17866 | 1 | 6.6 | 17900 | 1 | 10.0 | 17934 | 1 |
| .9 | 17833 | 1 | 3.3 | 17867 | 1 | 6.7 | 17901 | 1 | 10.1 | 17935 | 1 |
| .95 | 17834 | 1 | 3.4 | 17868 | 1 | 6.8 | 17902 | 1 | 10.2 | 17936 | 1 |
| 1.0 | 17835 | 1 | 3.5 | 17869 | 1 | 6.9 | 17903 | 1 | 10.3 | 17937 | 1 |
| 1.05 | 17836 | 1 | 3.6 | 17870 | 1 | 7.0 | 17904 | 1 | 10.4 | 17938 | 1 |
| 1.1 | 17837 | 1 | 3.7 | 17871 | 1 | 7.1 | 17905 | 1 | 10.5 | 17939 | 1 |
| 1.15 | 17838 | 1 | 3.8 | 17872 | 1 | 7.2 | 17906 | 1 | 10.6 | 17940 | 1 |
| 1.2 | 17839 | 1 | 3.9 | 17873 | 1 | 7.3 | 17907 | 1 | 10.7 | 17941 | 1 |
| 1.25 | 17840 | 1 | 4.0 | 17874 | 1 | 7.4 | 17908 | 1 | 10.8 | 17942 | 1 |
| 1.3 | 17841 | 1 | 4.1 | 17875 | 1 | 7.5 | 17909 | 1 | 10.9 | 17943 | 1 |
| 1.35 | 17842 | 1 | 4.2 | 17876 | 1 | 7.6 | 17910 | 1 | 11.0 | 17944 | 1 |
| 1.4 | 17843 | 1 | 4.3 | 17877 | 1 | 7.7 | 17911 | 1 | 11.1 | 17945 | 1 |
| 1.45 | 17844 | 1 | 4.4 | 17878 | 1 | 7.8 | 17912 | 1 | 11.2 | 17946 | 1 |
| 1.5 | 17845 | 1 | 4.5 | 17879 | 1 | 7.9 | 17913 | 1 | 11.3 | 17947 | 1 |
| 1.55 | 17846 | 1 | 4.6 | 17880 | 1 | 8.0 | 17914 | 1 | 11.4 | 17948 | 1 |
| 1.6 | 17847 | 1 | 4.7 | 17881 | 1 | 8.1 | 17915 | 1 | 11.5 | 17949 | 1 |
| 1.65 | 17848 | 1 | 4.8 | 17882 | 1 | 8.2 | 17916 | 1 | 11.6 | 17950 | 1 |
| 1.7 | 17849 | 1 | 4.9 | 17883 | 1 | 8.3 | 17917 | 1 | 11.7 | 17951 | 1 |
| 1.75 | 17850 | 1 | 5.0 | 17884 | 1 | 8.4 | 17918 | 1 | 11.8 | 17952 | 1 |
| 1.8 | 17851 | 1 | 5.1 | 17885 | 1 | 8.5 | 17919 | 1 | 11.9 | 17953 | 1 |
| 1.9 | 17852 | 1 | 5.2 | 17886 | 1 | 8.6 | 17920 | 1 | 12.0 | 17954 | 1 |
| 2.0 | 17853 | 1 | 5.3 | 17887 | 1 | 8.7 | 17921 | 1 | 12.1 | 17955 | 1 |
| 2.05 | 17854 | 1 | 5.4 | 17888 | 1 | 8.8 | 17922 | 1 | 12.2 | 17956 | 1 |
| 2.1 | 17855 | 1 | 5.5 | 17889 | 1 | 8.9 | 17923 | 1 | 12.3 | 17957 | 1 |
| 2.2 | 17856 | 1 | 5.6 | 17890 | 1 | 9.0 | 17924 | 1 | 12.4 | 17958 | 1 |
| 2.3 | 17857 | 1 | 5.7 | 17891 | 1 | 9.1 | 17925 | 1 | 12.5 | 17959 | 1 |
| 2.4 | 17858 | 1 | 5.8 | 17892 | 1 | 9.2 | 17926 | 1 | 12.6 | 17960 | 1 |
| 2.5 | 17859 | 1 | 5.9 | 17893 | 1 | 9.3 | 17927 | 1 | 12.7 | 17961 | 1 |
| 2.6 | 17860 | 1 | 6.0 | 17894 | 1 | 9.4 | 17928 | 1 | 12.8 | 17962 | 1 |
| 2.7 | 17861 | 1 | 6.1 | 17895 | 1 | 9.5 | 17929 | 1 | 12.9 | 17963 | 1 |
| 2.8 | 17862 | 1 | 6.2 | 17896 | 1 | 9.6 | 17930 | 1 | 13.0 | 17964 | 1 |
| 2.9 | 17863 | 1 | 6.3 | 17897 | 1 | 9.7 | 17931 | 1 | | | |

D R I L L B I T S E T C

GRAY shaded lines indicate NON-STOCK items. Allow 2-3 weeks extra order processing time.



IBS, INCORPORATED

Nitro-Carb Drill Bits P02

Metric Nitro-Carb Drill Bit Sets (P15)

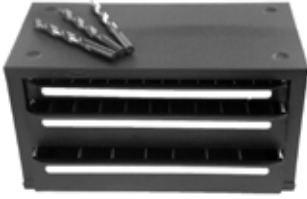

| IBS No. | Description |
|---------|--|
| 17450 | 25 Pc Metric Nitro-Carb Drill Bit Set 25 of the most popular drill bit sizes. 1mm thru 13mm by .5mm Complete with 3 drawer organizer |



METRIC NITRO-CARB DRILL BIT SET - INDEX

| IBS No. | Description |
|---------|--|
| 17451 | 19 Pc. Metric Nitro-Carb Drill Bit Set 1mm thru 10mm x .5mm Complete with metal index |
| 17452 | 25 Pc. Metric Nitro-Carb Drill Bit Set 1mm thru 13mm x .5mm Complete with metal index |

Extended Length Drill Bits Aircraft Drill Bits (P18)

- Ideal for drilling where extra reach is needed.
- 135° split point.
- Bright finish.
- High speed steel.



| IBS No. | Drill Size | Flute Length | Qty |
|---------|------------|--------------|-----|
| 59616 | 1/4 x 12 | 2-3/4 | 1 |
| 59620 | 5/16 x 12 | 3-3/16 | 1 |
| 59624 | 3/8 x 12 | 3-5/8 | 1 |
| 59628 | 7/16 x 12 | 4-1/16 | 1 |
| 59632 | 1/2 x 12 | 4-1/2 | 1 |

Economy Drill Bits (P2A)

- 118° point.
- General purpose drills for portable and machine drilling.
- Designed to perform well in low and medium carbon steel cast iron & wood.
- Bright finish.



| Drill Size | IBS No. | Qty. | Drill Size | IBS No. | Qty. |
|------------|---------|------|------------|---------|------|
| 1/16 | 17104 | 1 | 19/64 | 17119 | 1 |
| 5/64 | 17105 | 1 | 5/16 | 17120 | 1 |
| 3.32 | 17106 | 1 | 21/64 | 17121 | 1 |
| 7/64 | 17107 | 1 | 11/32 | 17122 | 1 |
| 1/8 | 17108 | 1 | 23/64 | 17123 | 1 |
| 9/64 | 17109 | 1 | 3/8 | 17124 | 1 |
| 5/32 | 17110 | 1 | 25/64 | 17125 | 1 |
| 11/64 | 17111 | 1 | 13/32 | 17126 | 1 |
| 3/16 | 17112 | 1 | 27/64 | 17127 | 1 |
| 13/64 | 17113 | 1 | 7/16 | 17128 | 1 |
| 7/32 | 17114 | 1 | 29/62 | 17129 | 1 |
| 15/64 | 17115 | 1 | 15/32 | 17130 | 1 |
| 1/4 | 17116 | 1 | 31/64 | 17131 | 1 |
| 17/64 | 17117 | 1 | 1/2 | 17132 | 1 |
| 9/32 | 17118 | 1 | | | |



ECONOMY DRILL BIT SET - INDEX

| IBS No. | Description |
|---------|---|
| 16701 | 29 Pc. Economy Drill Bit Set 1/16 thru 1/2 x 64ths Complete with metal index |

DRILL BITS ETC



Straight Shank Masonry Drill Bits (P20)



- Carbide tipped, surface treated, regular helix.
- Heat-resistant up to 1800°F.
- Diamond ground tungsten carbide tip is copper brazed for long life and heat resistance.
- Manufactured with a 15° negative grind to reduced carbide chipping.
- Wide flute provides fast dust removal in softer materials.
- Straight shank bits for professional use in 3-jaw chuck drill for drilling brick, concrete, cinder block, stone, etc.
- Produced according to ANSI standards to meet application tolerances.

| IBS No. | Size | Length (Overall x Flute) | Qty | IBS No. | Size | Length (Overall x Flute) | Qty |
|---------|------|--------------------------|-----|---------|------|--------------------------|-----|
| 15896 | 1/8 | 3 x 1-3/8 | 1 | 15904 | 9/16 | 6 x 3-1/2 | 1 |
| 15897 | 5/32 | 3 x 1-1/2 | 1 | 15905 | 5/8 | 6 x 3 | 1 |
| 15897A | 5/32 | 6 x 4 | 1 | 15906 | 3/4 | 6-3/4 x 3-1/2 | 1 |
| 15898 | 3/16 | 3-1/2 x 1-9/16 | 1 | 15907 | 7/8 | 6-1/4 x 3-1/2 | 1 |
| 15898A | 3/16 | 6 x 3-1/2 | 1 | 15908 | 7/8 | 13 x 9 | 1 |
| 15899 | 7/32 | 6 x 4 | 1 | 159081 | 1 | 6-1/4 x 4 | 1 |
| 15900 | 1/4 | 4 x 2-1/8 | 1 | 159082 | 1 | 13 x 9 | 1 |
| 159001 | 1/4 | 6 x 4 | 1 | 15902 | 3/8 | 6 x 3-1/2 | 1 |
| 159002 | 9/32 | 4 x 2-1/2 | 1 | 159021 | 7/16 | 6 x 3-1/2 | 1 |
| 15901 | 5/16 | 4-3/4 x 2-3/4 | 1 | 15903 | 1/2 | 6 x 3-1/2 | 1 |
| 159011 | 3/8 | 4-1/2 x 2-3/4 | 1 | | | | |

Straight Shank Masonry Drill Bits — 5 Pc Set (P15)

IBS No. 15998

- Sizes range from 5/32" to 1/2".
- Packaged in a clear plastic index.

Includes sizes:

| IBS No. | Size | Length | IBS No. | Size | Length |
|---------|------|--------|---------|------|--------|
| 15897A | 5/32 | 6 | 15902 | 3/8 | 6 |
| 15898A | 3/16 | 6 | 15903 | 1/2 | 6 |
| 159001 | 1/4 | 6 | | | |



D R I L L B I T S E T C



IBS, INCORPORATED

Masonry Drill Bits (P20)

SDS Plus Masonry Drill Bits

Faster drilling from a new carbide tip which features:

- Brazing and hardening are completed in a unique oven process guaranteeing a higher uniform quality.
- Self centering for precise starts.
- 160° angle means optimum elasticity and wear resistance for superior function and longevity.

Longer life from:

- Bronze alloy brazing of the carbide tip withstands heat better than silver used on many competitive products.
- High quality shot-peened steel strengthened to relieve tension and bit breakage.
- New wide fluting design flows the dust out of the hole faster, thus reducing friction and adding life to the carbide cutting.

D
R
I
L
L
B
I
T
S
E
T
C

| IBS No. | Size | Total Length | Usable Length | Qty | IBS No. | Size | Total Length | Usable Length | Qty |
|---------|------|--------------|---------------|-----|---------|-------|--------------|---------------|-----|
| 15800 | 5/32 | 4 | 2 | 1 | 15825 | 7/16 | 6 | 4 | 1 |
| 15801 | 5/32 | 6 | 4 | 1 | 15826 | 7/16 | 12 | 10 | 1 |
| 15802 | 3/16 | 4 | 2 | 1 | 15827 | 1/2 | 6 | 4 | 1 |
| 15803 | 3/16 | 6 | 4 | 1 | 15828 | 1/2 | 8 | 6 | 1 |
| 15804 | 3/16 | 8 | 6 | 1 | 15829 | 1/2 | 12 | 10 | 1 |
| 15805 | 3/16 | 12 | 10 | 1 | 15830 | 1/2 | 18 | 16 | 1 |
| 15806 | 7/32 | 6 | 4 | 1 | 15831 | 1/2 | 24 | 22 | 1 |
| 15807 | 7/32 | 8 | 6 | 1 | 15832 | 9/16 | 6 | 4 | 1 |
| 15808 | 7/32 | 16 | 14 | 1 | 15833 | 9/16 | 12 | 10 | 1 |
| 15809 | 1/4 | 4 | 2 | 1 | 15834 | 9/16 | 18 | 16 | 1 |
| 15810 | 1/4 | 6 | 4 | 1 | 15835 | 5/8 | 6 | 4 | 1 |
| 15811 | 1/4 | 8 | 6 | 1 | 15836 | 5/8 | 8 | 6 | 1 |
| 15812 | 1/4 | 12 | 10 | 1 | 15837 | 5/8 | 12 | 10 | 1 |
| 15813 | 1/4 | 18 | 16 | 1 | 15838 | 5/8 | 18 | 16 | 1 |
| 15814 | 9/32 | 4 | 2 | 1 | 15839 | 5/8 | 24 | 22 | 1 |
| 15815 | 9/32 | 6 | 4 | 1 | 15840 | 11/16 | 8 | 6 | 1 |
| 15816 | 5/16 | 4 | 2 | 1 | 15841 | 3/4 | 6 | 4 | 1 |
| 15817 | 5/16 | 6-1/2 | 4 | 1 | 15842 | 3/4 | 8 | 6 | 1 |
| 15818 | 5/16 | 8 | 6 | 1 | 15843 | 3/4 | 12 | 10 | 1 |
| 15819 | 5/16 | 12 | 10 | 1 | 15844 | 3/4 | 18 | 16 | 1 |
| 15820 | 3/8 | 6 | 4 | 1 | 15845 | 27/32 | 6 | 4 | 1 |
| 15821 | 3/8 | 8 | 6 | 1 | 15846 | 7/8 | 12 | 10 | 1 |
| 15822 | 3/8 | 12 | 10 | 1 | 15847 | 7/8 | 18 | 16 | 1 |
| 15823 | 3/8 | 18 | 16 | 1 | 15848 | 1 | 12 | 10 | 1 |
| 15824 | 3/8 | 24 | 22 | 1 | 15849 | 1 | 18 | 16 | 1 |

GRAY shaded lines indicate NON-STOCK items. Allow 2-3 weeks extra order processing time.

SDS Plus Masonry Drill Bits 5 Pc Set (P15)

IBS No. 15851

Set Includes:

- Sizes range from 5/32" to 1/2".
- Packaged in a clear plastic index.



| IBS No. | Size | Length | IBS No. | Size | Length |
|---------|------|--------|---------|------|--------|
| 15801 | 5/32 | 6 | 15820 | 3/8 | 6 |
| 15803 | 3/16 | 6 | 15827 | 1/2 | 6 |
| 15810 | 1/4 | 6 | | | |



IBS Type 187 Spotweld Drill Bits

- A rugged, high performance drill bit designed to effectively cut auto body panel spot welds.
- Cobalt steel permits speeds up to 30% greater than H.S.S. drills.
- Cobalt Steel is substantially more abrasion resistant, resulting in very long wearing cutting edges.



| IBS No. | Diameter MM | Approx Spotweld Size, Inches | Overall Length Inches | Qty |
|---------|-------------|------------------------------|-----------------------|-----|
| 19341 | 8.00 | 5/16 | 2.25 | 1 |
| 19342 | 10.00 | 3/8 | 2.25 | 1 |
| 19343 | 8.0 TE* | 5/16 | 3.62 | 1 |
| 19344 | 10.0 TE* | 3/8 | 3.62 | 1 |

* TE Twin End Drill Bits

These twin end drill bits will cut twice as many spot welds with the added advantage of longer reach to drill the less accessible spotwelds.



SPOTWELD DRILL BIT SET (P15)

| IBS No. | Description |
|---------|--|
| 19340 | 4 Pc. Spotweld Drill Bit Set (P15) 8.0, 10.00, 8.0TE, 10.0TE Complete with metal index |

Glass & Tile Drill Bits



- Industrial grade carbide to prevent cracking and ensure a long life.
- Pointed tip for accuracy of hole placement and easy centering.

Applications:

- For drilling glass, tiles, ceramics and mirrors.
- Reduced rotational speed (RPM) and use of water improves the drilling results.

Key Safety or Application Warning:

Glass and Tile Bits are only for rotary application. If you are using a Hammer Drill, you must TURN OFF THE HAMMER MODE.

| IBS No. | Diameter MM | Overall Length Inches | Qty |
|---------|-------------|-----------------------|-----|
| 15981 | 1/8 | 3-1/2 | 1 |
| 15982 | 5/32 | 3-1/2 | 1 |
| 15983 | 3/16 | 3-1/2 | 1 |
| 15984 | 1/4 | 3-1/2 | 1 |
| 15985 | 5/16 | 3-3/4 | 1 |
| 15986 | 3/8 | 4 | 1 |
| 15987 | 1/2 | 4 | 1 |



IBS, INCORPORATED

Miscellaneous Drill Bits (P20)

Ultra Point Acrylic Drill Bits



Acrylic drills are designed with ultra points for superior performance when drilling through plastics, acrylics, or laminate surfaces.

- **Special Hi-Molybdenum tool steel, gold surface treated** body, flute and point for maximum lubricity.
- **The ultra point is precision ground at a 60° angle** for gradual penetration to avoid cracking and chipping of the acrylic material.
- **Special 0° rake angle on cutting edge** eliminates grabbing when drill breaks through plastic, acrylic or laminate surfaces.
- All sizes over 1/4" have 1/4" shanks.

| IBS No. | Diameter | IBS No. | Diameter | IBS No. | Diameter | IBS No. | Diameter |
|---------|----------|---------|----------|---------|----------|---------|----------|
| 17280 | 3/32 | 17284 | 7/32 | 17288 | 11/32 | 17292 | 15/32 |
| 17281 | 1/8 | 17285 | 1/4 | 17289 | 3/8 | 17293 | 1/2 |
| 17282 | 5/32 | 17286 | 9/32 | 17290 | 13/32 | | |
| 17283 | 3/16 | 17287 | 5/16 | 17291 | 7/16 | | |



Sold in quantities of (1)

ULTRA POINT ACRYLIC DRILL BIT SET (P15)

| IBS No. | Description |
|---------|---|
| 17295 | 7 Pc Ultra Point Drill Bit Set (P15) 1/8 thru 1/2 by 16ths |

6-Flute Chatterless Countersinks



6-Flute Chatterless Countersinks are easy to use and provide the best finish. They quickly form an 82° countersink in a variety of materials allowing flat head fasteners to mount flush for a professional finish.

- **Special Hi-Molybdenum tool steel construction, gold surface treated** for maximum lubricity.
- **Unique 6-flute chatterless design has staggered cutting angles** to eliminate the harmonics that cause chatter in conventional tools – provides a more comfortable operation for users and a smoother finish in a wide variety of materials – saving user fatigue and time in finishing.
- **6-Flute design distributes the cutting load over six cutting edges** allowing edges to stay sharper longer to provide longer service life saving time and money.
- **Ideal for use on** hand tools, drill presses, milling machines and lathes.
- **Made in the USA**



| IBS No. | Size | For Screw Size | Shank | IBS No. | Size | For Screw Size | Shank |
|---------|--|----------------|------------|---------|-------|----------------|------------|
| 19380 | 1/4 | #4 | 1/4" Shank | 19385 | 3/4 | 3/8 | 1/2" Shank |
| 19381 | 5/16 | #6 | | 19386 | 7/8 | 7/16 | |
| 19382 | 3/8 | #8, #10 | | 19387 | 1 | 1/2 | |
| 19383 | 1/2 | 1/4" | 3/8" Shank | 19388 | 1-1/4 | 5/8 | 3/4" Shank |
| 19384 | 5/8 | 5/16 | | 19389 | 1-1/2 | 3/4 | |
| 19390 | 1/4 - 1/2 4PC Set 6-Flute Countersinks | | | | | | |

DRILL BITS ETC

IBS, INCORPORATED

Miscellaneous Drill Bits (P20)



Fluteless Countersinks

Deburring Tools

Our IBS high speed steel fluteless countersinks (deburring tools) offer superior quality, unique design and outstanding performance, yielding excellent workpiece finish. Designed for use in a wide variety of materials, including metal, plastic and wood. These tools can be easily sharpened by use of a small mounted grinding wheel inserted in the hole.



- Chatterless finish
- Single cutting edge for fast stock removal
- Free-cutting
- Easily sharpened
- Ideal for portable use

Fluteless Countersinks - 82° Pilotless, Round Shank

| IBS No. | Screw Size | Shank Diameter | Overall Length | Body Diameter | Qty |
|---------|------------|----------------|----------------|---------------|-----|
| 19300 | #4 & #5 | 1/4 | 1-1/2 | 1-7/16 | 1 |
| 19301 | #6 | 1/4 | 1-1/2 | 19/64 | 1 |
| 19302 | #8 | 1/4 | 1-5/8 | 11/32 | 1 |
| 19303 | #10 | 1/4 | 1-5/8 | 25/64 | 1 |
| 19304 | #12 & #14 | 1/4 | 1-7/8 | 9/16 | 1 |



Fluteless Countersinks - 82° Pilotless, Hex Shank for Portable Drills

| IBS No. | Screw Size | Shank Diameter | Overall Length | Body Diameter | Qty |
|---------|---------------|----------------|----------------|---------------|-----|
| 19305 | #2, #3, #4 | Hex | 1-27/32 | 1/4 | 1 |
| 19306 | #5, #6, #8 | Hex | 2 | 11/32 | 1 |
| 19307 | #10, #12, #14 | Hex | 2-5/16 | 9/16 | 1 |



Fluteless Countersink Sets



Round Shank Fluteless 5 Pc Countersink Set

82° Pilotless, Round Shank

| IBS No. | Set Contains |
|---------|-----------------------------------|
| 19310 | 19300, 19301, 19302, 19303, 19304 |



Hex Shank Fluteless 3 Pc Countersink Set

82° Pilotless, Hex Shank for Portable Drills

| IBS No. | Set Contains |
|---------|---------------------|
| 19315 | 19305, 19306, 19307 |



D R I L L B I T S E T C



IBS, INCORPORATED

Miscellaneous Drill Bits (P20)

Platinum Spiral Flute Step Drills

Drill Twice as Fast as a Straight Flute Step Drill

IBS Platinum Spiral Flute Step Drills cut twice as fast as straight flute step drills, quickly in various sheet materials up to 1/8" thick. Each step drill bit drills a range of sizes. The further the bit advances, the larger the diameter of the hole. Because step drill bits enter the material one step at a time, the operator can drill the desired hole by counting the individual steps, or by using a washer as a simple stop.

The **self-starting tip** eliminates the need for pilot holes.

Applications include: junction boxes, switch boxes, metal studs, electrical applications, lighting fixtures, autobody work, and many other uses.

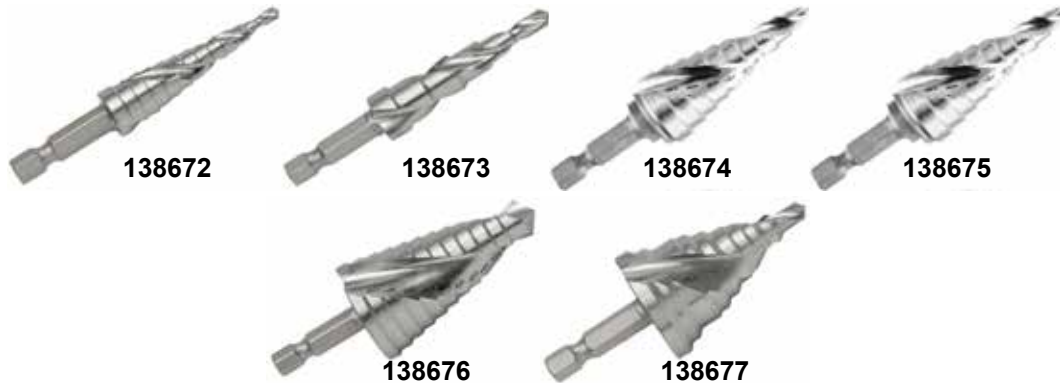

NITRO-CARB STEP DRILLS

| IBS No | Description | |
|--------|---|------------------------|
| 138672 | 1/8-1/2 X 1/32 Platinum Spiral Flute Step Drill | 1/4 HEX SHANK 13 HOLES |
| 138673 | 3/16-1/2 X 1/16 Platinum Spiral Flute Step Drill | 1/4 HEX SHANK 6 HOLES |
| 138674 | 3/16-3/4 X 1/16 Platinum Spiral Flute Step Drill | 1/4 HEX SHANK 10 HOLES |
| 138675 | 3/16-7/8 X 1/16 Platinum Spiral Flute Step Drill | 1/4 HEX SHANK 12 HOLES |
| 138676 | 7/16 -1-1/8 X 1/16 Platinum Spiral Flute Step Drill | 1/4 HEX SHANK 12 HOLES |
| 138677 | 7/8-1-1/8 X 1/4 Platinum Spiral Flute Step Drill | 1/2 HEX SHANK 2 HOLES |

Platinum Spiral Flute Step Drill Travel Trays

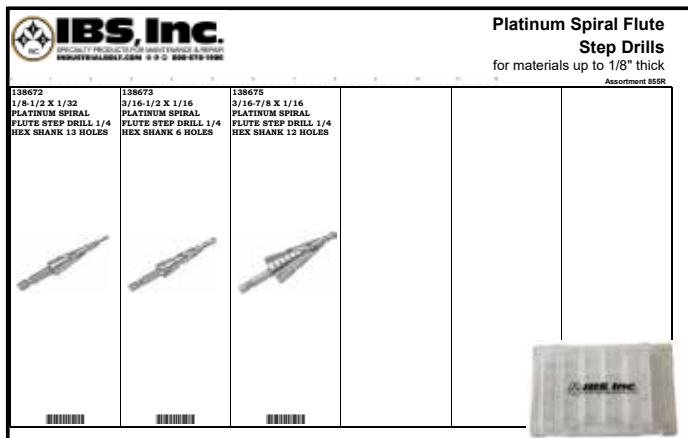

3Pc Spiral Flute Step Drills Starter Set Travel Tray

IBS No. 855R • 3 Items • 3 Pcs

Packaged in a Locking Plastic Travel Tray for Easy Storage & Organization

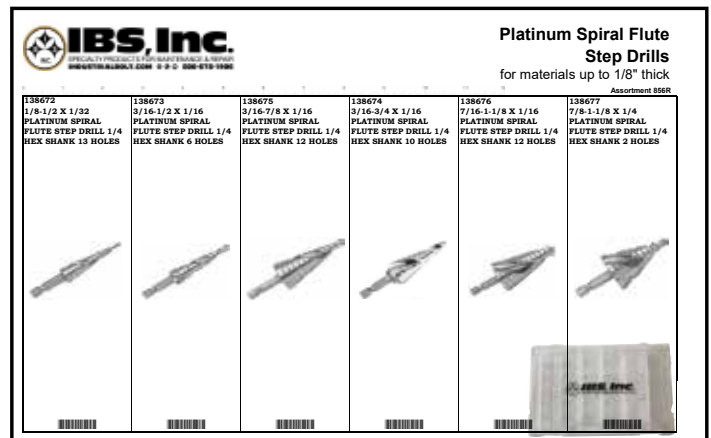

6Pc Spiral Flute Step Drills Travel Tray

IBS No. 856R • 6 Items • 6 Pcs

Packaged in a Locking Plastic Travel Tray for Easy Storage & Organization

D
R
I
L
L
B
I
T
S
E
T
C



Nitro-Carb Step Drills

Nitro-Carb Step Drills are in a class unto themselves. Nitro-Carb Step Drills include as many as 13 different hole sizes in a single bit, eliminating the need for an entire tool box full of specific sized drill bits. And its built-in differences result in a tool that cuts faster and cleaner and gives a true, round hole every time.

- **Double Flute Design** — Means faster cutting action producing a hole quickly and efficiently saving time and money.
- **Multiple Stepped for Your Multiple Drilling Needs** —includes as many as 13 different hole sizes in a single bit, eliminating the need for specific sized drill bits.
- **Proper hole size** is achieved by counting the steps as they penetrate the work and stopping the pressure when the desired hole size is reached.
- **Deburring is Automatic** once the proper hole diameter is attained, the hole is automatically deburred by the cutting edge of the next larger step.
- **Hardened steel for long life** - each Nitro-Carb Step Drill is constructed of industrial grade high speed molybdenum steel, heat-treated to a Rockwell of between 61 and 63 on the "C" scale and tempered to assure maximum strength for long life.
- **Self-Centering Split Point Tip** - the split point virtually eliminates skidding and the need for center punching; the tip gives sure starts even on curved surfaces such as pipe and conduit.



128672



128673



128674



128675



128676



128677

NITRO-CARB STEP DRILLS

| Unibit Size # | IBS Size # | IBS No. | No. of Holes | Hole | Increments | Shank | |
|---------------|------------|---------|-----------------------------------|-------------|------------|-------------|--|
| #1 | #1 | 128672 | 13 | 1/8 - 1/2 | 1/32 | 1/4 Hex | |
| #4 | #2 | 128673 | 6 | 3/16 - 1/2 | 1/4 | 1/4 Hex | |
| #3 | #3 | 128674 | 9 | 1/4 - 3/4 | 1/16 | 1/4 Hex | |
| #8 | #4 | 128675 | 12 | 3/16 - 7/8 | 1/16 | 1/4 Hex | |
| #12 | #5 | 128676 | 10 | 1/4 - 1-3/8 | 1/8 | 3/8 w/Flats | |
| #2 | #29 | 128677 | 13 | 1/4 - 1 | 1/16 | 3/8 w/Flats | |
| — | — | 128686 | 3 Pc Set: #1, #2, #4 | | | | |
| — | — | 749R | 6 Pc Set: #1, #2, #3, #4, #5, #29 | | | | |



IBS No. 128686

3 Piece Set Contains:

- (128672) 1/8-1/2
- (128673) 3/16-1/2
- (128675) 3/16-7/8



Nitro-Carb Step Drill Travel Tray

IBS No. 749R • 6 Items • 6 Pcs

Contains all 6 sizes packaged in an adjustable compartment small plastic travel tray for easy storage and organization.

RECOMMENDED DRILL SPEEDS

| Hole Size | RPM |
|-----------|-------------|
| Up to 1/4 | 1500 — 1750 |
| 1/4 — 1/2 | 1000 — 1250 |
| 1/2 — 3/4 | 500 — 1000 |
| 3/4 — 1 | 300 — 500 |

D R I L L B I T S E T C



IBS, INCORPORATED

Step Reamers (P17)

Step Reamers

**THE FASTEST AND EASIEST WAY TO ENLARGE HOLES IN MATERIALS UP TO 1/2" THICK!
INCREDIBLY FAST AND ACCURATE!**



- **GOLD OXIDE COATING** enhances lubricity, reduces friction, and increases toughness.
- **SIZES ARE ETCHED INSIDE THE FLUTES** which will last longer and allow users to read the sizes even after use.
- **MADE OF M2 HSS TOOL STEEL** for optimum performance in tough metals — means it stays sharper longer, saving time and money.
- **1/2" SHANK WITH 3 FLATS ON THE SHANK** allows easy positive chuck grip, eliminating spinning or slipping in the chuck for safety, and speed — great for keyless chucks!
- **EACH REAMER HAS 5 STEPS IN 1/16" INCREMENTS** — 3 Step Reamers can replace 15 reamers, which saves money in inventory.
- **CHAMFER ON EACH STEP** — deburs the cut for a perfectly finished hole every time, eliminating sharp edges for a safer finish, saving time and money.
- **Full 1/2" cutting depth** for use in thicker material than standard step drills for more versatility in more applications.



STEP REAMERS

| IBS No. | Description | Qty. |
|---------|-----------------------------|------|
| 18531 | 5/16 to 9/16 Step Reamer | 1 |
| 18532 | 9/16 to 13/16 Step Reamer | 1 |
| 18533 | 13/16 to 1-1/16 Step Reamer | 1 |
| 18534 | 3 Pc Step Reamer Set | 1 |



3 Pc STEP REAMER SET
(5/16 to 1-1/16)
IBS No. 18534

D
R
I
L
L
B
I
T
S
E
T
C

IBS, INCORPORATED

Nitro-Carb Spiral Reamers (P17)



Platinum Series Spiral Reamers

STRAIGHT SHANK, LEFT HAND HELIX, RIGHT HAND CUT, COLLAR STOP HSS
"PLATINUM SERIES — THE PROOF IS IN THE PERFORMANCE"



- **M7 TOOL STEEL & NOMO COATING** equip this reamer to cut stainless steel and tough alloys. An exclusive combination of high speed steel, superior geometry, and our unique NOMO treatment (Nitride on Margin Only) make short work of enlarging holes in framework and structural steel.
- **FITS INTO SMALL HOLES** smaller diameter allows the user to enlarge much smaller holes to desired diameter, reducing the need for progressively larger tools. Ideal for harder to cut metals such as stainless steel.
- **TAPER ANGLE DESIGN** distributes cutting forces along the edges. Multiple tapered cutting edges evenly distribute the cutting load for effortless reaming, resulting in less damage and replacement costs.
- **SAFE TO USE** — Flutes of the reamer turn in a forward (down and away) direction, so chips are safely ejected away from the operator.
- **HSS SAFETY COLLAR** prevents over penetration for safety and accuracy.

Applications:

Industrial applications include steel erection, automotive, truck and trailer manufacturing.

Ideal for:

- Enlarging misaligned holes
- Fuel tank mounting
- Truck frame drilling
- Tool box & accessory mounting
- Spring hangers
- Trailer hitch, 5th wheel & tow hook mounting

D
R
I
L
L
B
I
T
S
E
T
C



IBS, INCORPORATED

Nitro Carb Spiral Reamers (P17)

Platinum Series Spiral Reamers

STRAIGHT SHANK, LEFT HAND HELIX, RIGHT HAND CUT, COLLAR STOP HSS

"PLATINUM SERIES — THE PROOF IS IN THE PERFORMANCE"

Engineered exclusively to enlarge and align existing holes; especially in tight spots. The ideal maintenance reamer.

- Three flats on the shank — allows for strong positive chuck grip and eliminates slippage in the chuck.
- Gold surface treated for additional lubricity for cooler operation and longer life.
- Effortlessly fits into small holes
- Quickly aligns structural steel
- Deburs welded & punched holes
- Cuts stainless steel and tough alloys
- Fits most power tools
- Ideal for maintenance and repair

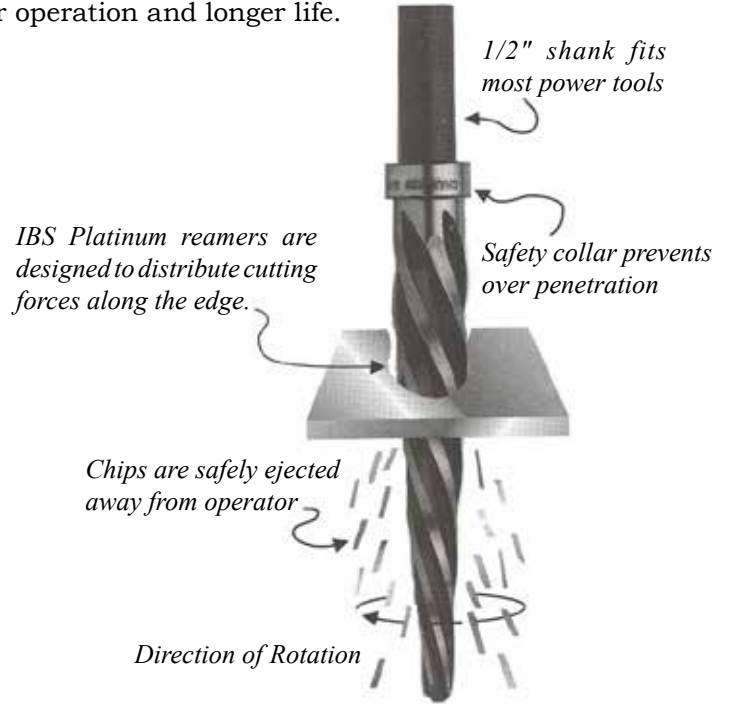

D
R
I
L
L
B
I
T
S
E
T
C

| IBS No. | Dia. | Shank Dia | Decimal Equivalent | No. of Flutes | Point Dia. | Flute Length | Overall Length | Pilot Drill | Drill No. |
|---------|------|-----------|--------------------|---------------|------------|--------------|----------------|-------------|-----------|
| 18501 | 1/4 | 1/4 | .2500 | 4 | .195 | 2-5/16 | 4 | 3/16 | 16808 |
| 18502 | 5/16 | 5/16 | .3125 | 4 | .215 | 3 | 4-5/8 | 17/64 | 16813 |
| 18503 | 3/8 | 3/8 | .3750 | 4 | .250 | 3 | 4-5/8 | 5/16 | 16816 |
| 18504 | 7/16 | 7/16 | .4375 | 4 | .250 | 3-1/4 | 5-7/8 | 3/8 | 16820 |
| 18505 | 1/2 | 1/2 | .5000 | 5 | .281 | 3-15/16 | 5-7/8 | 3/8 | 16820 |
| 18506 | 9/16 | 1/2 | .5625 | 5 | .343 | 3-15/16 | 5-7/8 | 7/16 | 16824 |
| 18507 | 5/8 | 1/2 | .6250 | 5 | .343 | 4-1/2 | 6-3/8 | 7/16 | 16824 |
| 18510 | 3/4 | 1/2 | .7500 | 5 | .406 | 4-15/16 | 6-3/8 | 1/2 | 16828 |
| 18513 | 7/8 | 1/2 | .8750 | 5 | .500 | 5-3/16 | 6-3/8 | 19/32 | 16838 |
| 18515 | 1 | 1/2 | 1.0000 | 5 | .719 | 5-3/16 | 6-3/8 | 7/8 | 16856 |

SETS

18517 4 Pc Platinum Spiral Reamer Set (5/16, 3/8, 7/16, & 1/2) P15

18518 4 Pc Platinum Spiral Reamer Set (3/8, 1/2, 5/8, & 3/4) P15



4 Pc Platinum Spiral Reamer Set
(5/16, 3/8, 7/16, & 1/2)
IBS No. 18517



4 Pc Platinum Spiral Reamer Set
(3/8, 1/2, 5/8 & 3/4)
IBS No. 18518

IBS, INCORPORATED

Nitro Carb Spiral Reamers (P17)



Nitro-Carb Hole Hog Reamers Hole Enlargers Hole Hog™ Super Premium Core Drills



Made of special Hi-Molybdenum tool steel, these reamers feature a gold surface treated body and clearance for maximum lubricity, close tolerance construction, three flats on the shank and four flutes. They are designed exclusively to enlarge existing holes.

This high performance tool is designed to enlarge existing holes by as much as 160% of the existing hole's diameter. The four flute design and modified "Hole Hog" point prevent the catching and hogging-in commonly experienced when standard S&D drills break through thinner material such as truck frames. The flatted 1/2" shank makes this tool extremely useful in portable drilling.

HOLE HOG REAMERS 4-5/16" Overall Length, 1-7/8 Flute Length

| IBS No. | Diameter (in.) | Pilot Drill | Qty |
|---------|----------------|-------------|-----|
| 18524 | 3/8 | 1/4 | 1 |
| 18526 | 1/2 | 5/16 | 1 |
| 18528 | 5/8 | 25/64 | 1 |
| 18530 | 3/4 | 15/32 | 1 |

Hole Hog Reamer / Pilot Drill Sets (P15)

These sets contain the reamers described above and mechanics length Nitro-Carb drill bit in a metal index. The reamers have flats along the shank for ease of use with portable drilling.



HOLE HOG REAMER SETS w/Drill Bits Made from Special High Molybdenum Tool Steel

| IBS No. | # of Pcs | Reamer Sizes included | Drill Sizes included |
|---------|----------|-----------------------|-------------------------|
| 18521 | 8 Pc | 3/8, 1/2, 5/8, 3/4 | 1/4, 5/16, 25/64, 15/32 |
| 18522 | 6 Pc | 3/8, 1/2, 5/8 | 1/4, 5/16, 25/64 |
| 18523 | 6 Pc | 1/2, 5/8, 3/4 | 5/16, 25/64, 15/32 |

D
R
I
L
L
B
I
T
S
E
T
C



IBS, INCORPORATED

High Speed Taps (P08)

IBS Nitro Carb "DRAPS"



- Made of **Hi-Molybdenum tool steel** for longer tool life.
- **3 Flats on the Shank** reduces slippage and provides for faster tool changes and alignment in keyless chuck.
- **Ground threads** and a **plug lead tap** design allows for smooth entry, easy tapping and excellent thread finish.
- **Black & Gold surface treatment** reduces friction, holds lubricant and provides improved chip removal resulting in cooler cutting and extended life.
- **135° Split Point** allows easier starts and higher speed drilling, eliminating the need for a center punch or pilot hole.
- **Longer drill point** allows for use in thicker materials.

DRAPS - NC

| IBS No. | Thread Size | Max Material Thickness | Thread Length |
|---------|-------------|------------------------|---------------|
| 17150 | 4-40 | 0.368 | 0.564 |
| 17151 | 6-32 | 0.468 | 0.376 |
| 17152 | 8-32 | 0.539 | 0.376 |
| 17153 | 10-24 | 0.606 | 0.496 |
| 17154 | 12-24 | 0.677 | 0.496 |
| 17155 | 1/4-20 | 0.746 | 0.626 |
| 17156 | 5/16-18 | 0.889 | 0.683 |
| 17157 | 3/8-16 | 1.031 | 0.746 |
| 17158 | 7/16-14 | 1.172 | 0.882 |
| 17159 | 1/2-13 | 1.378 | 0.940 |

DRAPS - NF

| IBS No. | Thread Size | Max Material Thickness | Thread Length |
|---------|-------------|------------------------|---------------|
| 17173 | 8-36 | 0.540 | 0.376 |
| 17160 | 10-32 | 0.608 | 0.496 |
| 17161 | 1/4-28 | 0.750 | 0.626 |
| 17162 | 5/16-24 | 0.893 | 0.683 |
| 17163 | 3/8-24 | 1.036 | 0.746 |
| 17164 | 7/16-20 | 1.178 | 0.880 |
| 17165 | 1/2-20 | 1.384 | 0.940 |

DRAPS - METRIC

| IBS No. | Thread Size | Max Material Thickness | Thread Length |
|---------|-------------|------------------------|---------------|
| 17166 | M3-5 | 0.403 | 0.624 |
| 17167 | M4-7 | 0.538 | 0.376 |
| 17168 | M5-8 | 0.610 | 0.496 |
| 17169 | M6-1.0 | 0.746 | 0.626 |
| 17170 | M8-1.25 | 0.892 | 0.686 |
| 17171 | M10-1.5 | 1.037 | 0.746 |
| 17172 | M12-1.75 | 1.373 | 0.942 |

6 Pc Coarse Machine Screw Nitro Carb DRAP Set

IBS No. 17175

Contains sizes: 6-32, 8-32, 10-24, 10-32, 12-24, 1/4-20 packaged in a locking plastic case for easy storage and organization.



7 Pc Fine Thread Nitro Carb DRAP Set

IBS No. 17176

Contains sizes: 8-36, 10-32, 1/4-28, 5/16-24, 3/8-24, 7/16-20, 1/2-20 packaged in a folding cloth pouch for easy storage and organization.



7 Pc Coarse Thread Nitro Carb DRAP Set

IBS No. 17177

Contains sizes: 8-32, 10-24, 1/4-20, 5/16-18, 3/8-16, 7/16-14, 1/2-13 packaged in a folding cloth pouch for easy storage and organization.



6 Pc Machine Screw Nitro Carb DRAP Travel Tray

IBS No. 17178

Contains sizes: 8-32, 10-24, 12-24, 1/4-20, 5/16-18, 3/8-16 packaged in a locking plastic travel tray for easy storage and organization.



6 Pc Metric Nitro Carb DRAP Travel Tray

IBS No. 17179

Contains sizes: M4, M5, M6, M8, M10, M12 packaged in a locking plastic travel tray for easy storage and organization.



Sold in quantities of (1)

DRILL BITS ETC



Speeds and Feeds for Drill Bits

The speed of a drill bit is usually measured in terms of the rate at which the outside or periphery of the tool moves in relation to the work being drilled. The common term for this is Surface Feet per Minute (SFM). The relation of SFM and Revolutions per Minute (RPM) is indicated by the following formula:

$$\text{RPM} = 3.8 \times \left[\frac{\text{SFM}}{\text{Drill Diameter in inches}} \right]$$

The most economical speed for operating a drill bit will depend on variables, some of which are:

1. Composition and hardness of material being drilled.
2. Depth of the hole being drilled.
3. Use of cutting fluids.
4. Type and condition of drilling equipment.
5. Quality of holes desired.

Speeds shown in the accompanying table of cutting speeds include a range in feet per minute. In most drilling situations it is usually better to start with a slower speed and build up to the maximum after a trial hole may indicate the drill bit can be run faster.

The following information provides widely recommended drill bit speeds in feet per minute for a wide range of materials. These speeds give the user a good starting point but may be adjusted to slower or faster depending on the variables listed previously and the resulting performance. The optimum speed must be established through trial.

Standard drill bit feed information is provided below to help establish the proper feed rate of different diameters. This is particularly useful when a drill press, etc. is being used.

Drill Bit Feeds

| DIAMETER OF DRILL BIT (INCHES) | NORMAL FEED | HEAVY FEED |
|---|--------------------|-------------------|
| from 1/16 to 1/8 | .001 -.002 | .002 -.004 |
| over 1/8 to 1/4 | .002 -.004 | .004 -.008 |
| over 1/4 to 1/2 | .004 -.008 | .008 -.016 |
| over 1/2 to 1 | .008 -.016 | .016 -.024 |
| over 1 | .016 -.024 | .024 -.032 |

The following charts convert surface feet per minute to revolutions per minute for fractional, letter and number drills. To use these charts, locate the drill bit diameter to be used on the left side of the chart and the desired surface feet per minute at the top (reference the following chart for the material to be drilled). The point where the two columns meet will give you a good guide regarding the revolutions per minute to be used as a starting point.

D
R
I
L
L
B
I
T
S
E
T
C



Surface Cutting Speeds For Various Materials

Reference the chart below to determine the proper surface speed for use in the following charts.

D
R
I
L
L
B
I
T
S
E
T
C

| Material | Speed: Ft/Min | Material | Speed: Ft/Min |
|-----------------------------------|------------------|-----------------------------|------------------|
| Aluminum & its alloys | 40 to 50 | Bakelite | 90 to 100 |
| Common brass and bronze | 200 to 300 | Allegheny metal | 40 to 50 |
| High Tensile Bronze | 70 to 150 | Manganese copper | 20 to 30 |
| Magnesium and its alloys | 250 to 400 | Chromalloy | 40 to 50 |
| Plastics | 100 to 150 | Magnet steel (soft) | 40 to 50 |
| Plastics containing glass fibers | 70 to 90 | Tool steel (RB80) | 40 to 60 |
| Formica | 70 to 100 | Tool steel (RB 32-34) | 40 to 50 |
| Hardwoods | 300 to 400 | Nitralloy 135 | 50 to 60 |
| Die Castings (zinc base) | 300 to 400 | Waspalloy | 12 to 15 |
| Copper | 70 to 100 | Crucible HY-Tuf (AMS 6418) | 15 to 25 |
| Automotive steel forgings | 40 to 50 | Crucible UHS 260 | 7 to 15 |
| Nickel steel (3/2%) | 20 to 50 | Timken HS 220 | 15 to 25 |
| Spring Steel | 30 to 40 | Inco Tricent | 10 to 20 |
| Mild steel (2. - .3 carbon) | 80 to 110 | Vascojet X4 and 1000 | 7 to 15 |
| Medium Steel (.4 - .5 carbon) | 70 to 80 | Thermold J | 7 to 15 |
| Alloy Steel-Manganese (7-13%) | 30 to 40 | Trinidur | 12 to 15 |
| Molybdenum steel | 60 to 70 | Discalloy AMS 5733 | 12 to 15 |
| Monel | 50 to 60 | Vitallium | 10 to 12 |
| Titanium (RC 32 - RC 34) | 20 to 50 | Udimet 500 | 12 to 15 |
| Tool steel (anneled 1.2 carbon) | 20 to 50 | Iconel 700 | 7 to 15 |
| Permalloy (77% nickel) | 50 to 60 | Rene 41 | 7 to 15 |
| Soft cast iron | 100 to 150 | Armco (17-4 PH and 17-7 PH) | 15 to 20 |
| Medium hard cast iron | 70 to 100 | Iconet AMS 5685 | 10 to 12 |
| Hard Cast Iron | 30 to 70 | SAE 4340, 4360 & AMS 6415 | 7 to 15 |
| Malleable iron | 80 to 90 | USS STRUX - MOD 98BV40 | 7 to 15 |
| Stainless steel 200 series | 50 to 70 | SAE 4330 - Mod. AMS 6407 | 15 to 25 |
| 18-8 stainless steel & 300 series | 20 to 60 | H-11 AMS 6485 | 7 to 15 |
| Stainless steel 400 series | 20 to 60 | A 286 AMS 5736 | 15 to 20 |
| Zamak | 200 to 300 | S-816AMS 5765 | 12 to 15 |
| Hard rubber | 90 to 100 | | |



Fractional Drill Cutting Speeds in RPM

| Drill | Feet Per Minute | | | | | | | | | | | | | | |
|-------|-----------------|------|------|------|------|------|------|------|-------|-------|-------|-------|-------|-------|-------|
| | 10 | 12 | 15 | 20 | 25 | 30 | 35 | 40 | 45 | 50 | 60 | 70 | 80 | 90 | 100 |
| 1/64 | 2445 | 2934 | 3667 | 4889 | 6112 | 7334 | 8556 | 9778 | 11001 | 12223 | 14668 | 17112 | 19557 | 22001 | 24446 |
| 1/32 | 1222 | 1467 | 3667 | 2445 | 3056 | 3667 | 4278 | 4889 | 5500 | 6112 | 7334 | 8556 | 9778 | 11001 | 12223 |
| 3/64 | 815 | 978 | 1833 | 1630 | 2037 | 2445 | 2852 | 3259 | 3667 | 4074 | 4889 | 5704 | 6519 | 7334 | 8149 |
| 1/16 | 611 | 733 | 1222 | 1222 | 1528 | 1833 | 2139 | 2445 | 2750 | 3056 | 3667 | 4278 | 4889 | 5500 | 6112 |
| 5/64 | 489 | 587 | 917 | 978 | 1222 | 1467 | 1711 | 1956 | 2200 | 2445 | 2934 | 3422 | 3911 | 4400 | 4889 |
| 3/32 | 407 | 489 | 733 | 815 | 1019 | 1222 | 1426 | 1630 | 1833 | 2037 | 2445 | 2852 | 3259 | 3667 | 4074 |
| 7/64 | 349 | 419 | 611 | 698 | 873 | 1048 | 1222 | 1397 | 1572 | 1746 | 2095 | 2445 | 2794 | 3143 | 3492 |
| 1/8 | 306 | 367 | 524 | 611 | 764 | 917 | 1070 | 1222 | 1375 | 1528 | 1833 | 2139 | 2445 | 2750 | 3056 |
| 9/64 | 272 | 326 | 458 | 543 | 679 | 815 | 951 | 1086 | 1222 | 1358 | 1630 | 1901 | 2173 | 2445 | 2716 |
| 5/32 | 244 | 293 | 407 | 489 | 611 | 733 | 856 | 978 | 1100 | 1222 | 1467 | 1711 | 1956 | 2200 | 2445 |
| 11/64 | 222 | 267 | 367 | 444 | 556 | 667 | 778 | 889 | 1000 | 1111 | 1333 | 1556 | 1778 | 2000 | 2222 |
| 3/16 | 204 | 244 | 333 | 407 | 509 | 611 | 713 | 815 | 917 | 1019 | 1222 | 1426 | 1630 | 1833 | 2037 |
| 13/64 | 188 | 226 | 306 | 376 | 470 | 564 | 658 | 752 | 846 | 940 | 1128 | 1316 | 1504 | 1692 | 1880 |
| 7/32 | 175 | 210 | 282 | 349 | 437 | 524 | 611 | 698 | 786 | 873 | 1048 | 1222 | 1397 | 1572 | 1746 |
| 15/64 | 163 | 196 | 262 | 326 | 407 | 489 | 570 | 652 | 733 | 815 | 978 | 1141 | 1304 | 1467 | 1630 |
| 1/4 | 153 | 183 | 244 | 306 | 382 | 458 | 535 | 611 | 688 | 764 | 217 | 1070 | 1222 | 1275 | 1528 |
| 9/32 | 136 | 163 | 229 | 272 | 340 | 407 | 475 | 543 | 611 | 679 | 815 | 951 | 1086 | 1222 | 1358 |
| 5/16 | 122 | 147 | 204 | 244 | 306 | 367 | 428 | 489 | 550 | 611 | 733 | 856 | 978 | 1100 | 1222 |
| 11/32 | 111 | 133 | 183 | 222 | 278 | 333 | 389 | 444 | 500 | 556 | 667 | 778 | 889 | 1000 | 1111 |
| 7/16 | 87 | 105 | 167 | 175 | 218 | 262 | 306 | 349 | 393 | 437 | 524 | 611 | 698 | 786 | 873 |
| 15/32 | 81 | 98 | 131 | 163 | 204 | 244 | 285 | 326 | 367 | 407 | 489 | 570 | 652 | 733 | 815 |
| 1/2 | 76 | 92 | 122 | 153 | 191 | 229 | 267 | 306 | 344 | 382 | 458 | 535 | 611 | 688 | 764 |
| 9/16 | 68 | 81 | 115 | 136 | 170 | 204 | 238 | 272 | 306 | 340 | 407 | 475 | 543 | 611 | 679 |
| 5/8 | 61 | 73 | 102 | 122 | 153 | 183 | 214 | 244 | 275 | 306 | 367 | 428 | 489 | 550 | 611 |
| 11/16 | 56 | 67 | 92 | 111 | 139 | 167 | 194 | 222 | 250 | 278 | 333 | 389 | 444 | 500 | 556 |
| 3/4 | 51 | 61 | 83 | 102 | 127 | 153 | 178 | 204 | 229 | 255 | 306 | 357 | 407 | 458 | 509 |
| 13/16 | 47 | 56 | 76 | 94 | 118 | 141 | 165 | 188 | 212 | 235 | 282 | 329 | 376 | 423 | 470 |
| 7/8 | 44 | 52 | 71 | 87 | 109 | 131 | 153 | 175 | 1965 | 218 | 262 | 306 | 349 | 393 | 437 |
| 15/16 | 41 | 49 | 65 | 81 | 102 | 122 | 143 | 163 | 183 | 204 | 244 | 285 | 326 | 367 | 407 |
| 1 | 38 | 46 | 57 | 76 | 95 | 115 | 134 | 153 | 172 | 191 | 229 | 267 | 306 | 344 | 382 |

D R I L L B I T S E T C



IBS, INCORPORATED

Technical Information

Letter Drill Cutting Speeds in RPM

D
R
I
L
L
B
I
T
S
E
T
C

| Drill | Feet Per Minute | | | | | | | | | | | | | | |
|-------|-----------------|-----|-----|-----|-----|-----|-----|-----|-----|-----|-----|------|------|------|------|
| | 10 | 12 | 15 | 20 | 25 | 30 | 35 | 40 | 45 | 50 | 60 | 70 | 80 | 90 | 100 |
| A | 163 | 196 | 245 | 326 | 408 | 490 | 571 | 653 | 735 | 818 | 982 | 1145 | 1309 | 1472 | 1636 |
| B | 160 | 193 | 241 | 321 | 401 | 481 | 562 | 642 | 722 | 803 | 963 | 1124 | 1284 | 1445 | 1605 |
| C | 158 | 189 | 237 | 316 | 395 | 473 | 552 | 631 | 710 | 789 | 947 | 1105 | 1292 | 1420 | 1578 |
| D | 155 | 186 | 233 | 311 | 388 | 466 | 543 | 621 | 699 | 778 | 937 | 1089 | 1245 | 1400 | 1556 |
| E | 153 | 183 | 229 | 306 | 386 | 458 | 535 | 611 | 687 | 764 | 917 | 1070 | 1222 | 1375 | 1528 |
| F | 149 | 178 | 223 | 297 | 372 | 446 | 520 | 595 | 669 | 778 | 934 | 1089 | 1245 | 1400 | 1556 |
| G | 146 | 176 | 220 | 293 | 366 | 439 | 512 | 585 | 659 | 732 | 878 | 1024 | 1170 | 1317 | 1463 |
| H | 144 | 172 | 215 | 287 | 359 | 431 | 503 | 574 | 646 | 718 | 862 | 1005 | 1149 | 1292 | 1436 |
| I | 140 | 169 | 211 | 281 | 351 | 421 | 492 | 562 | 632 | 702 | 842 | 983 | 1123 | 1264 | 1404 |
| J | 138 | 165 | 207 | 276 | 345 | 414 | 483 | 552 | 621 | 690 | 827 | 965 | 1103 | 1241 | 1379 |
| K | 136 | 163 | 204 | 272 | 340 | 408 | 476 | 544 | 612 | 680 | 815 | 951 | 1087 | 1223 | 1359 |
| L | 132 | 158 | 198 | 263 | 329 | 395 | 461 | 527 | 593 | 659 | 790 | 922 | 1054 | 1185 | 1317 |
| M | 129 | 155 | 194 | 259 | 324 | 388 | 453 | 518 | 583 | 648 | 777 | 907 | 1036 | 1166 | 1295 |
| N | 126 | 152 | 190 | 253 | 316 | 379 | 442 | 506 | 569 | 633 | 759 | 886 | 1012 | 1139 | 1265 |
| O | 121 | 145 | 181 | 242 | 302 | 363 | 423 | 484 | 544 | 605 | 725 | 846 | 967 | 1088 | 1209 |
| P | 118 | 142 | 177 | 237 | 296 | 355 | 414 | 473 | 532 | 592 | 710 | 828 | 946 | 1065 | 1183 |
| Q | 115 | 138 | 173 | 230 | 288 | 345 | 403 | 460 | 518 | 575 | 690 | 805 | 920 | 1035 | 1150 |
| R | 113 | 135 | 169 | 225 | 282 | 338 | 394 | 451 | 507 | 564 | 676 | 789 | 902 | 1014 | 1127 |
| S | 110 | 132 | 135 | 220 | 274 | 329 | 384 | 439 | 494 | 549 | 659 | 769 | 878 | 988 | 1098 |
| T | 107 | 128 | 160 | 213 | 267 | 320 | 373 | 427 | 480 | 533 | 640 | 746 | 853 | 959 | 1066 |
| U | 104 | 125 | 156 | 208 | 259 | 311 | 363 | 415 | 467 | 519 | 623 | 727 | 830 | 934 | 1038 |
| V | 101 | 122 | 152 | 203 | 253 | 304 | 355 | 405 | 456 | 507 | 608 | 709 | 810 | 912 | 1013 |
| W | 99 | 119 | 148 | 198 | 247 | 297 | 346 | 396 | 445 | 495 | 594 | 693 | 792 | 891 | 989 |
| X | 96 | 115 | 144 | 192 | 240 | 289 | 337 | 385 | 433 | 481 | 576 | 672 | 769 | 865 | 962 |
| Y | 95 | 113 | 142 | 189 | 236 | 284 | 331 | 378 | 425 | 473 | 567 | 662 | 756 | 851 | 945 |
| Z | 92 | 111 | 139 | 185 | 231 | 277 | 324 | 370 | 416 | 462 | 555 | 647 | 740 | 832 | 925 |

NOTE: For speeds higher than tabulated, multiply all values by ten and for speeds lower divide by ten.



Number Drill Cutting Speeds in RPM

| Drill | Feet Per Minute | | | | | | | | | | | | | | |
|-------|-----------------|-----|-----|-----|-----|------|------|------|------|------|------|------|------|------|------|
| | 10 | 12 | 15 | 20 | 25 | 30 | 35 | 40 | 45 | 50 | 60 | 70 | 80 | 90 | 100 |
| 1 | 168 | 201 | 251 | 335 | 419 | 503 | 586 | 670 | 754 | 838 | 1005 | 1173 | 1340 | 1508 | 1675 |
| 2 | 173 | 207 | 259 | 346 | 432 | 519 | 605 | 691 | 778 | 864 | 1037 | 1210 | 1382 | 1555 | 1728 |
| 3 | 179 | 215 | 269 | 359 | 448 | 538 | 628 | 717 | 807 | 897 | 1076 | 1255 | 1434 | 1614 | 1793 |
| 4 | 183 | 219 | 274 | 366 | 457 | 548 | 640 | 731 | 822 | 914 | 1097 | 1280 | 1462 | 1645 | 1828 |
| 5 | 186 | 223 | 279 | 372 | 465 | 558 | 651 | 743 | 836 | 930 | 1115 | 1301 | 1487 | 1673 | 1859 |
| 6 | 187 | 225 | 281 | 374 | 468 | 562 | 655 | 749 | 843 | 936 | 1123 | 1310 | 1498 | 1685 | 1872 |
| 7 | 190 | 228 | 285 | 380 | 475 | 570 | 665 | 760 | 855 | 950 | 1140 | 1330 | 1520 | 1710 | 1900 |
| 8 | 192 | 230 | 288 | 384 | 480 | 576 | 672 | 768 | 864 | 960 | 1151 | 1343 | 1535 | 1727 | 1919 |
| 9 | 195 | 234 | 292 | 390 | 487 | 585 | 682 | 780 | 877 | 975 | 1169 | 1364 | 1559 | 1754 | 1949 |
| 10 | 197 | 237 | 296 | 385 | 494 | 592 | 691 | 790 | 888 | 987 | 1184 | 1382 | 1579 | 1777 | 1974 |
| 11 | 200 | 240 | 300 | 400 | 500 | 600 | 700 | 800 | 900 | 1000 | 1200 | 1400 | 1600 | 1800 | 2000 |
| 12 | 202 | 243 | 303 | 404 | 505 | 606 | 707 | 808 | 909 | 1010 | 1213 | 1415 | 1617 | 1819 | 2021 |
| 13 | 206 | 248 | 310 | 413 | 516 | 619 | 723 | 826 | 929 | 1032 | 1239 | 1450 | 1652 | 1859 | 2065 |
| 14 | 210 | 252 | 315 | 420 | 525 | 630 | 735 | 839 | 944 | 1050 | 1259 | 1469 | 1679 | 1889 | 2099 |
| 15 | 212 | 255 | 318 | 424 | 531 | 637 | 743 | 849 | 955 | 1064 | 1276 | 1489 | 1802 | 1914 | 2127 |
| 16 | 216 | 259 | 324 | 432 | 540 | 647 | 755 | 863 | 971 | 1079 | 1295 | 1511 | 1726 | 1942 | 2158 |
| 17 | 221 | 265 | 331 | 442 | 552 | 662 | 773 | 883 | 994 | 1104 | 1325 | 1546 | 1766 | 1987 | 2208 |
| 18 | 225 | 270 | 338 | 451 | 563 | 676 | 789 | 901 | 1014 | 1130 | 1356 | 1582 | 1808 | 2034 | 2260 |
| 19 | 230 | 276 | 345 | 460 | 575 | 690 | 805 | 920 | 1035 | 1151 | 1381 | 1611 | 1841 | 2071 | 2301 |
| 20 | 237 | 285 | 356 | 474 | 593 | 712 | 830 | 949 | 1068 | 1186 | 1423 | 1660 | 1898 | 2135 | 2372 |
| 21 | 240 | 288 | 360 | 480 | 601 | 721 | 841 | 961 | 1081 | 1201 | 1441 | 1681 | 1922 | 2162 | 2402 |
| 22 | 243 | 292 | 365 | 487 | 608 | 730 | 852 | 973 | 1095 | 1217 | 1460 | 1703 | 1946 | 2190 | 2433 |
| 23 | 248 | 298 | 372 | 496 | 620 | 744 | 868 | 992 | 1116 | 1240 | 1488 | 1736 | 1984 | 2232 | 2480 |
| 24 | 251 | 302 | 377 | 503 | 628 | 754 | 880 | 1005 | 1131 | 1257 | 1508 | 1759 | 2010 | 2262 | 2513 |
| 25 | 255 | 307 | 383 | 511 | 639 | 766 | 894 | 1022 | 1150 | 1276 | 1533 | 1789 | 2044 | 2300 | 2555 |
| 26 | 260 | 312 | 390 | 520 | 650 | 780 | 909 | 1039 | 1169 | 1299 | 1559 | 1819 | 2078 | 2338 | 2598 |
| 27 | 265 | 318 | 398 | 531 | 663 | 796 | 928 | 1061 | 1194 | 1327 | 1592 | 1857 | 2122 | 2388 | 2653 |
| 28 | 272 | 326 | 408 | 544 | 680 | 816 | 952 | 1087 | 1223 | 1360 | 1631 | 1903 | 2175 | 2447 | 2719 |
| 29 | 281 | 337 | 421 | 562 | 702 | 843 | 983 | 1123 | 1264 | 1405 | 1685 | 1966 | 2247 | 2528 | 2809 |
| 30 | 297 | 357 | 446 | 585 | 743 | 892 | 1040 | 1189 | 1338 | 1487 | 1784 | 2081 | 2378 | 2676 | 2973 |
| 31 | 318 | 382 | 477 | 637 | 796 | 955 | 1114 | 1273 | 1432 | 1592 | 1910 | 2228 | 2546 | 2865 | 3183 |
| 32 | 329 | 395 | 494 | 659 | 823 | 988 | 1153 | 1317 | 1482 | 1647 | 1976 | 2305 | 2634 | 2964 | 3293 |
| 33 | 338 | 406 | 507 | 676 | 845 | 1014 | 1183 | 1352 | 1521 | 1690 | 2028 | 2366 | 2704 | 3042 | 3380 |
| 34 | 344 | 413 | 516 | 688 | 860 | 1032 | 1204 | 1376 | 1549 | 1721 | 2065 | 2409 | 2753 | 3097 | 3442 |
| 35 | 347 | 417 | 521 | 694 | 866 | 1042 | 1215 | 1389 | 1563 | 1736 | 2088 | 2430 | 2778 | 3125 | 3472 |
| 36 | 359 | 430 | 538 | 717 | 898 | 1076 | 1255 | 1435 | 1614 | 1794 | 2152 | 2511 | 2870 | 3228 | 3587 |
| 37 | 367 | 441 | 551 | 735 | 918 | 1102 | 1285 | 1469 | 1653 | 1837 | 2204 | 2571 | 2938 | 3006 | 3673 |
| 38 | 376 | 452 | 564 | 753 | 941 | 1129 | 1317 | 1505 | 1693 | 1882 | 2258 | 2634 | 3010 | 3387 | 3763 |
| 39 | 384 | 461 | 576 | 768 | 960 | 1152 | 1344 | 1536 | 1728 | 1920 | 2303 | 2687 | 3071 | 3455 | 3839 |
| 40 | 390 | 468 | 585 | 780 | 974 | 1169 | 1364 | 1559 | 1754 | 1949 | 2339 | 2729 | 3118 | 3508 | 3898 |

D R I L L B I T S E T C



IBS, INCORPORATED

Technical Information

Metric Drill Cutting Speeds in RPM

| Drill | Feet Per Minute | | | | | |
|-------|-----------------|------|------|-------|-------|-------|
| | 20 | 30 | 50 | 70 | 80 | 100 |
| 0.5 | 3878 | 5817 | 9695 | 13573 | 15512 | 19389 |
| 1.0 | 1939 | 2908 | 4847 | 6786 | 7756 | 9695 |
| 1.5 | 1293 | 1939 | 3232 | 4524 | 5171 | 6463 |
| 2.0 | 971 | 1456 | 2427 | 3397 | 3883 | 4854 |
| 2.5 | 776 | 1165 | 1941 | 2717 | 3105 | 3882 |
| 3.0 | 647 | 970 | 1617 | 2264 | 2587 | 3234 |
| 3.5 | 554 | 832 | 1386 | 1940 | 2218 | 2772 |
| 4.0 | 485 | 728 | 1213 | 1698 | 1940 | 2425 |
| 4.5 | 431 | 647 | 1078 | 1509 | 1724 | 2156 |
| 5.0 | 388 | 582 | 970 | 1359 | 1552 | 1940 |
| 6.0 | 323 | 485 | 809 | 1132 | 1294 | 1617 |
| 7.0 | 277 | 415 | 693 | 970 | 1109 | 1386 |
| 8.0 | 243 | 364 | 605 | 849 | 970 | 1213 |
| 9.0 | 216 | 323 | 539 | 755 | 832 | 1075 |
| 10.0 | 194 | 291 | 485 | 679 | 776 | 970 |
| 11.0 | 176 | 265 | 441 | 617 | 706 | 882 |
| 12.0 | 162 | 243 | 404 | 566 | 647 | 809 |
| 13.0 | 149 | 224 | 373 | 522 | 597 | 749 |
| 14.0 | 139 | 208 | 346 | 485 | 554 | 693 |
| 15.0 | 129 | 194 | 323 | 453 | 517 | 647 |
| 16.0 | 121 | 182 | 303 | 424 | 485 | 606 |
| 17.0 | 114 | 171 | 285 | 399 | 457 | 571 |
| 18.0 | 108 | 162 | 269 | 377 | 431 | 539 |
| 19.0 | 102 | 153 | 255 | 357 | 409 | 511 |
| 20.0 | 97 | 146 | 243 | 340 | 388 | 485 |
| 22.0 | 88 | 132 | 221 | 309 | 353 | 441 |
| 24.0 | 81 | 121 | 202 | 283 | 323 | 404 |
| 26.0 | 75 | 112 | 187 | 261 | 299 | 373 |
| 28.0 | 69 | 104 | 173 | 243 | 277 | 346 |
| 30.0 | 65 | 97 | 162 | 226 | 259 | 323 |

NOTE: For speeds higher than tabulated, multiply all values by ten and for speeds lower divide by ten.

SUGGESTIONS FOR MAXIMUM DRILL PERFORMANCE

1. A reduced speed is recommended to start the drill.
2. The harder the material the slower the speed.
3. The larger the diameter the slower the speed.
4. Do not force feed. Let the drill cut at its own pace.
5. Once the bore is started, either keep the drill cutting or remove it. Idling of the cutting edge will harden the steel and dull the bit.
6. At the point of break-through, lighten the feed pressure.
7. Avoid side pressure on the drill bit whenever possible.

DRILL BITS ETC



Decimal Equivalent Chart For Drill Sizes

| Drill Size | mm | Dec. In. | Drill Size | mm | Dec. In. | Drill Size | mm | Dec. In. | Drill Size | mm | Dec. In. |
|------------|------|----------|------------|------|----------|------------|-------|----------|------------|-------|----------|
| — | 0.10 | .0039 | 45 | 2.08 | .0820 | 5 | 5.22 | .2055 | 7/16 | 11.11 | .4375 |
| — | 0.20 | .0079 | 44 | 2.18 | .0860 | 4 | 5.31 | .2090 | 29/64 | 11.51 | .4531 |
| — | 0.25 | .0098 | 43 | 2.26 | .0890 | 3 | 5.41 | .2130 | 15/32 | 11.91 | .4688 |
| — | 0.30 | .0118 | 42 | 2.37 | .0935 | 7/32 | 5.58 | .2188 | — | 12.00 | .4724 |
| 80 | 0.34 | .0135 | 3/32 | 2.38 | .0938 | 2 | 5.61 | .2210 | 31/64 | 12.30 | .4844 |
| 79 | 0.37 | .0145 | 41 | 2.44 | .0960 | 1 | 5.79 | .2280 | 1/2 | 12.70 | .5000 |
| 1/64 | 0.40 | .0156 | 40 | 2.50 | .0980 | A | 5.94 | .2340 | — | 13.00 | .5118 |
| 78 | 0.41 | .0160 | 39 | 2.53 | .0995 | 15/64 | 5.95 | .2344 | 33/64 | 13.10 | .5156 |
| 77 | 0.46 | .0180 | 38 | 2.58 | .1015 | — | 6.00 | .2362 | 17/32 | 13.49 | .5312 |
| — | 0.50 | .0197 | 37 | 2.64 | .1040 | B | 6.05 | .2380 | 35/64 | 13.89 | .5469 |
| 76 | 0.51 | .0200 | 36 | 2.71 | .1065 | C | 6.15 | .2420 | — | 14.00 | .5512 |
| 75 | 0.53 | .0210 | 7/64 | 2.78 | .1094 | D | 6.25 | .2460 | 9/16 | 14.29 | .5625 |
| 74 | 0.57 | .0225 | 35 | 2.70 | .1100 | 1/4 | 6.35 | .2500 | 37/64 | 14.68 | .5781 |
| — | 0.60 | .0236 | 34 | 2.82 | .1110 | E | 6.35 | .2500 | — | 15.00 | .5906 |
| 73 | 0.61 | .0240 | 33 | 2.87 | .1130 | F | 6.53 | .2570 | 19/32 | 15.08 | .5938 |
| 72 | 0.64 | .0250 | 32 | 2.95 | .1160 | G | 6.63 | .2610 | 39/64 | 15.48 | .6094 |
| 71 | 0.66 | .0250 | — | 3.00 | .1181 | 17/64 | 6.75 | .2656 | 5/8 | 15.88 | .6250 |
| — | 0.70 | .0276 | 31 | 3.05 | .1200 | H | 6.76 | .2660 | — | 16.00 | .6299 |
| 70 | 0.71 | .0280 | 1/8 | 3.18 | .1250 | I | 6.91 | .2720 | 41/64 | 16.27 | .6406 |
| 69 | 0.74 | .0292 | 30 | 3.26 | .1285 | — | 7.00 | .2756 | 21/32 | 16.67 | .6562 |
| — | 0.75 | .0295 | 29 | 3.45 | .1360 | J | 7.04 | .2770 | — | 17.00 | .6693 |
| 68 | 0.79 | .0310 | 28 | 3.57 | .1405 | K | 7.14 | .2810 | 43/64 | 17.07 | .6719 |
| 1/32 | 0.79 | .0313 | 9/64 | 3.57 | .1406 | 9/32 | 7.14 | .2812 | 11/16 | 17.46 | .6875 |
| — | 0.80 | .0315 | 27 | 3.65 | .1440 | L | 7.37 | .2900 | 45/84 | 17.86 | .7031 |
| 67 | 0.81 | .0320 | 26 | 3.73 | .1470 | M | 7.40 | .2950 | — | 18.00 | .7087 |
| 66 | 0.84 | .0330 | 25 | 3.80 | .1495 | 19/64 | 7.54 | .2969 | 23/32 | 18.26 | .7188 |
| 65 | 0.89 | .0350 | 24 | 3.86 | .1520 | N | 7.67 | .3020 | 47/64 | 18.65 | .7344 |
| — | 0.90 | .0354 | 23 | 3.91 | .1540 | 5/16 | 7.94 | .3125 | — | 19.00 | .7480 |
| 64 | 0.91 | .0360 | 5/32 | 3.97 | .1562 | — | 8.00 | .3150 | 3/4 | 19.05 | .7500 |
| 63 | 0.94 | .0370 | 22 | 3.99 | .1570 | O | 8.03 | .3160 | 49/64 | 19.45 | .7656 |
| 62 | 0.97 | .0380 | — | 4.00 | .1575 | P | 8.20 | .3230 | 25/32 | 19.84 | .7812 |
| 61 | 0.99 | .0390 | 21 | 4.04 | .1500 | 21/64 | 8.33 | .3281 | — | 20.00 | .7874 |
| — | 1.00 | .0394 | 20 | 4.09 | .1610 | Q | 8.43 | .3320 | 51/64 | 20.24 | .7969 |
| 60 | 1.02 | .0400 | 19 | 4.22 | .1660 | R | 8.61 | .3390 | 13/16 | 20.64 | .8125 |
| 59 | 1.04 | .0410 | 18 | 4.31 | .1695 | 11/32 | 8.73 | .3438 | — | 21.00 | .8268 |
| 58 | 1.07 | .0420 | 11/64 | 4.37 | .1719 | S | 8.84 | .3480 | 53/64 | 21.02 | .8281 |
| 57 | 1.09 | .0430 | 17 | 4.39 | .1730 | — | 9.00 | .3543 | 27/32 | 21.43 | .8438 |
| 56 | 1.18 | .0465 | 16 | 4.50 | .1770 | T | 9.09 | .3580 | 55/64 | 21.84 | .8594 |
| 3/64 | 1.19 | .0469 | 15 | 4.57 | .1800 | 23/64 | 9.13 | .3594 | — | 22.00 | .8861 |
| 55 | 1.32 | .0520 | 14 | 4.62 | .1820 | U | 9.35 | .3680 | 7/8 | 22.23 | .8750 |
| 54 | 1.40 | .0550 | 13 | 4.70 | .1850 | 3/8 | 9.53 | .3750 | 57/64 | 22.62 | .8906 |
| 53 | 1.51 | .0595 | 3/16 | 4.76 | .1875 | V | 9.55 | .3770 | — | 23.00 | .9055 |
| 1/16 | 1.59 | .0625 | 12 | 4.80 | .1890 | W | 9.80 | .3860 | 29/32 | 23.02 | .9062 |
| 52 | 1.61 | .0635 | 11 | 4.85 | .1910 | 25/64 | 9.92 | .3906 | 59/64 | 23.42 | .9219 |
| 51 | 1.70 | .0670 | 10 | 4.91 | .1935 | — | 10.00 | .3937 | 15/16 | 23.81 | .9375 |
| 50 | 1.78 | .0700 | 9 | 4.98 | .1960 | X | 10.08 | .3970 | — | 24.00 | .9449 |
| 49 | 1.85 | .0730 | — | 5.00 | .1968 | Y | 10.26 | .4040 | 61/64 | 24.21 | .9531 |
| 48 | 1.93 | .0760 | 8 | 5.05 | .1990 | 13/32 | 10.32 | .4062 | 31/32 | 24.61 | .9688 |
| 5/64 | 1.98 | .0781 | 7 | 5.11 | .2010 | Z | 10.40 | .4130 | — | 25.00 | .9842 |
| 47 | 1.99 | .0785 | 13/64 | 5.16 | .2031 | 27/64 | 10.72 | .4219 | 63/64 | 25.00 | .9844 |
| — | 2.00 | .0787 | 6 | 5.18 | .2040 | — | 11.00 | .4331 | 1 | 25.40 | 1.000 |
| 46 | 2.06 | .0810 | — | — | — | — | — | — | — | 25.50 | 1.039 |

D R I L L B I T S E T C



NES External Rethreading Tools

An essential tool for anyone who deals with nuts and bolts in: maintenance, construction, garages, plumbing, agriculture and engineering.



- Adjusts automatically to thread diameter & pitch.
- No measuring of thread required.
- Can be used on left and right hand threads.
- Can be used on both inch and metric threads.
- Two hardened steel blades (58RC) guided by the existing thread, regroove the damaged area.

Turn handle (A) to raise floating blades (B).



Place the tool over the thread to be repaired.

Turn handle (A) to lower floating blades into grooves of thread and tighten by hand only.



Turn the NES External fastener repair tool in the direction of the arrow.



NES 1A EXTERNAL TOOL IBS No. 99152

| NES 1A | OD | Pipe | L | W | H | R |
|--------|---------------|------------|-------|-------|--------|---------|
| in. | 5/32 to 11/16 | up to 7/16 | 2-3/8 | 29/32 | 2-7/16 | 2-11/16 |
| mm. | 4-18 | | 61 | 23 | 62 | 68 |



NES 2 EXTERNAL TOOL IBS No. 99162

| NES 2 | OD | Pipe | L | W | H | R |
|-------|----------------|--------------|-------|-------|--------|-------|
| in. | 11/16 to 1-1/2 | 3/8 to 1-1/8 | 4-1/8 | 1-1/2 | 4-5/16 | 4-5/8 |
| mm. | 17-38 | | 105 | 32 | 110 | 117 |

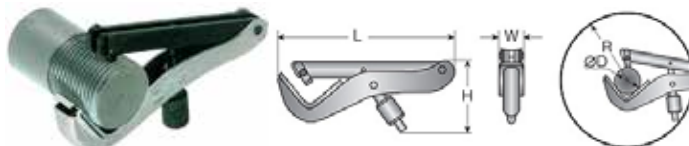

NES 3 EXTERNAL TOOL IBS No. 99163

| NES 3 | OD | Pipe | L | W | H | R |
|-------|------------|------------|-----|-------|-------|-------|
| in. | 1-1/4 to 5 | 1 to 4-1/2 | 12 | 1-3/4 | 5-1/8 | 9-7/8 |
| mm. | 32-128 | | 305 | 44 | 130 | 250 |

NES Universal Thread Restorer 4 Pc Tool Kit



| IBS No. | Description |
|---------|--|
| 122254 | NES Universal Thread Restorer 4 Pc Tool Kit Contains all three NES Rethreading Tools. Replacement blades and internal thread cleaner tool included. |

NES Internal Thread Cleaner / Restoring Tool



| IBS No. | Description |
|---------|--|
| 122252 | NES Internal Thread Cleaner Restoring Tool |
| 122253 | NES Internal Thread Cleaner Replacement Blades |

NES Replacement Blades



| IBS No. | Description |
|---------|-------------------------|
| 122249 | NES1 Replacement Blades |
| 122250 | NES2 Replacement Blades |
| 122251 | NES3 Replacement Blades |

D R I L L B I T S E T C



iNES Internal Rethreading Tap

An essential tool for anyone who deals with nuts and bolts in: maintenance, construction, garages, plumbing, agriculture and engineering.

- Adjusts automatically to thread diameter & pitch.
- No measuring of thread required.
- Can be used on left and right hand threads.
- Can be used on both inch & metric threads.
- Hardened steel blade (62RC) guided by the existing threads, regrooves the damaged area.



Turn knurled knob (K) to fully retract the blade (B) into the housing. Insert iNES tool into the threaded hole or bore to be repaired.

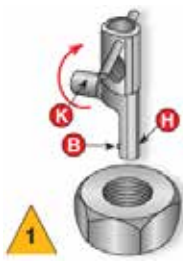

Turn knurled knob (K) to extend blade (B) into the thread groove on an undamaged section and tighten by hand only.



Rotate the iNES internal fastener repair tool by the cross rod, as shown, in the desired direction.

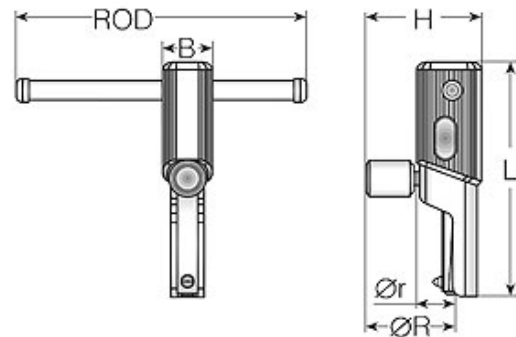

iNES #21 IBS No. 126289

| iNES 22 | OD | L | B | H | Rod | Or | OR |
|---------|--------------|--------|-------|-------|--------|-------|--------|
| in. | 5/16 to 7/16 | 4-5/16 | 11/16 | 1-3/4 | 4-9/16 | 11/16 | 1-9/16 |
| mm. | 12 to 16 | 109 | 18 | 45 | 116 | 17 | 39 |
| pipes | 1/16 - 3/16 | | | | | | |

iNES #24 IBS No. 126296

| iNES 24 | OD | L | B | H | Rod | Or | OR |
|---------|--------------|-------|--------|-------|-------|--------|-------|
| in. | 7/8 to 1-1/4 | 5-3/8 | 1-1/16 | 2-1/2 | 6-3/8 | 1-1/16 | 2-1/8 |
| mm. | 22 to 32 | 136 | 27 | 64 | 161 | 27 | 54 |
| pipes | 1/2 to 7/8 | | | | | | |

iNES #22 IBS No. 126294

| iNES 22 | OD | L | B | H | Rod | Or | OR |
|---------|------------|--------|-------|-------|--------|-------|--------|
| in. | 1/2 to 5/8 | 4-5/16 | 11/16 | 1-3/4 | 4-9/16 | 11/16 | 1-9/16 |
| mm. | 12 to 16 | 109 | 18 | 45 | 116 | 17 | 39 |
| pipes | 1/4 - 3/8 | | | | | | |

iNES #25 IBS No. 126297

| iNES 25 | OD | L | B | H | Rod | Or | OR |
|---------|----------------|--------|-------|--------|--------|-------|--------|
| in. | 1-1/4 to 2-1/8 | 6-7/16 | 1-1/2 | 3-3/16 | 7-9/16 | 1-3/8 | 2-7/16 |
| mm. | 22 to 32 | 163 | 38 | 81 | 192 | 35 | 62 |
| pipes | 7/8 to 1-3/4 | | | | | | |

iNES #23 IBS No. 126295

| iNES 23 | OD | L | B | H | Rod | Or | OR |
|---------|----------------|-------|-------|--------|-------|-------|-------|
| in. | 11/16 to 13/16 | 4-3/8 | 13/16 | 2-1/16 | 5-1/8 | 13/16 | 1-3/4 |
| mm. | 16 to 20 | 111 | 21 | 53 | 130 | 20 | 45 |
| pipes | 3/8 - 1/2 | | | | | | |

D R I L L B I T S E T C



IBS, INCORPORATED

Tools (T03)

D
R
I
L
L
B
I
T
S
E
T
C

3 Pc iNES Internal Set

| IBS No. | Description |
|---------|---|
| 126302 | Contains #21 Small, #22 Medium & #23 Large iNES tools. Replacement blades included. |



3 & 6 Pc NES Internal & External Tool Sets

| IBS No. | Description |
|---------|--|
| 126303 | Contains NES 1A Small External Tool, #21 Small & #22 Medium iNES Internal tools. Replacement blades included. |
| 126304 | Contains NES 1A Small & #2 Large External Tools, #21 Small, #22 Small, #23 Medium & #24 Large iNES Internal tools. Replacement blades included for internal tools. |



iNES Replacement Blades & Nylon Pads



Replacement Blade

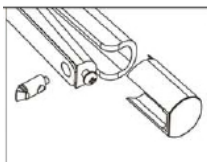

Nylon pads or for use with Internal tools to be used for repair for threads in aluminum or other soft metals.

| IBS No. | Description |
|---------|-----------------------------|
| 126305 | iNES #21 Replacement Blades |
| 126298 | iNES #22 Replacement Blades |
| 126299 | iNES #23 Replacement Blades |
| 126300 | iNES #24 Replacement Blades |
| 126301 | iNES #25 Replacement Blades |
| 126306 | iNES #21 Nylon Pad |
| 126306 | iNES #22 Nylon Pad |
| 126306 | iNES #23 Nylon Pad |
| 126306 | iNES #24 Nylon Pad |

ThreadMate™ Set & External Tool



- Fixes any thread in diameter between M5-M12 (#12 - 1/2") internal and M4-M13 (5/32" - 1/2") external.
- A great solution for outdoor technicians, industrial maintenance, workshops, auto garages, marine use, farmers, auto mechanics, professional and hobby users, etc.
- Small size fits any toolbox.
- External thread repair tool repairs and restores external threads.
- Easy to use set with built-in knob — just set and turn.
- Kit contains replaceable nylon pads for soft metal repair jobs.
- Clean thread in both ways - inside out, or outside in.
- Easy to operate, no special thread knowledge required — works on USS, SAE, Metric, Fine, Coarse, etc.

THREADMATE™ KIT & EXTERNAL TOOL

| IBS No. | Description | Qty |
|---------|------------------------------------|-----|
| 126290 | MINI ThreadMate™ Kit | 1 |
| 126292 | MINI ThreadMate™ External Tool | 1 |
| 126291 | Replacement Blades Ext. Tool 1 pr. | 1 |



External Deburring Tools (T03)

- Quickly repairs damaged threads from 7/64" to 7/8".
- Hardened HRC 60 Steel blades remove burrs and uneven ridges from threaded rods, pipes and more.
- Works on hardened and mild steels, Grade 8 fasteners, stainless steel, brass copper, aluminum, plastics, wood, etc.
- 1/4" hex shank attaches to your drill quickly.
- Most effective at low speeds — recommended speed should not exceed 500 RPM in a clockwise direction only.



| IBS No. | Description | Shank | Qty |
|---------|-------------------------------------|-------|-----|
| 51951 | Small Deburring Tool 7/64" to 7/16" | 1/4" | 1 |
| 51950 | Medium Deburring Tool 5/16" to 7/8" | 1/4" | 1 |



REMOVE BURRS



REPAIR DAMAGED THREADS



WORKS ON A VARIETY OF MATERIALS

GrabIt® Drill-Out Broken Bolt Extractor Set

Removing stripped screws and bolts can be a frustrating experience, and now there's a solution! This 4 pc extractor kit removes broken bolts from as small as 1/4" to 1/2" (6mm-12mm) and can drill up to Grade 8 or 10.9 class fasteners. Each Drill-Out is a drill bit and extractor in one and is uniquely designed to drill into the rough surfaces when bolts break.

SINGLE STEP EXTRACTION FAST & EASY TO USE

A drill bit and extractor in one tool, the DRILL-OUT creates a unique interaction between drill bit and extractor, resulting in maximum impact and break out ability. Broken bolts and studs are removed quickly and easily without damaging the fastener threads.

- **Unique drill tip** allows the tool to stay on center.
- **Self-centering drill tip eliminates** walking or wandering.
- **No grinding, center punching or pilot hole** required.
- **Works** on jagged, uneven and rough breaks.
- **Tempered twice for extra hardness;** resulting in multiple extractions per tool.
- **Made from the highest quality M2 HSS Steel.**
- **MADE IN THE USA.**

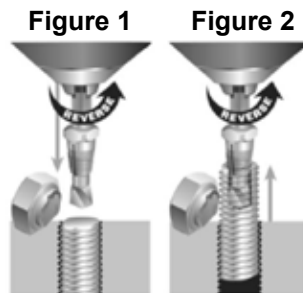

DRILLING:

1. Choose the correct size DRILL-OUT.
2. Secure round end in the drill chuck and tighten.
3. Thread collet/extractor back against drill chuck.
4. Set drill in reverse and begin drilling at the suggested RPM's.(see Figure 1)
REMEMBER: Hole must be straight & on center. DO NOT allow collet/extractor to move down toward tip while drilling.
5. Stop drilling just before the collet/extractor reaches the broken bolt. (See Figure 2)
6. Apply penetrating oil to help loosen bolt.

| IBS No. | Description | Qty |
|---------|---|-----|
| 133309 | Grab-It Drill Out Extractor 4 Pc Set 1/4" to 1/2" (6mm to 12mm) | 1 |

WARNING: Always wear safety glasses when operating or near power tools. Cutting tools may shatter when broken.



Power-Outs™ Double Edged Screw Extractors

These patented double-edged screw extractors are made from hardened chrome vanadium steel with a burnished finish. The cutting edges are polished, and the part number and dimensions are laser marked on the shank for easy identification.



POWER OUTS DOUBLE EDGED SCREW EXTRACTORS

| IBS No. | Size | SW Diam (in) | Drill Diam (in) | | Screw Size (in) | |
|---------|--|--------------|-----------------|-------|-----------------|-------|
| | | | Min | Max | Min | Max |
| 139501 | 1 | 1/4 | 1/8 | 3/16 | 3/16 | 1/4 |
| 139502 | 2 | 3/8 | 3/16 | 9/32 | 5/16 | 3/8 |
| 139503 | 3 | 1/2 | 1/4 | 3/8 | 7/16 | 1/2 |
| 139504 | 4 | 5/8 | 11/32 | 1/2 | 1/2 | 9/16 |
| 139505 | 5 | 3/4 | 7/16 | 5/8 | 5/8 | 3/4 |
| 139506 | 6 | 7/8 | 9/16 | 3/4 | 7/8 | 1 |
| 139507 | 7 | 1 | 3/4 | 15/16 | 1 | 1-1/8 |
| 139395 | 5 Pc Set (Sizes 1-5 in a plastic pouch) | | | | | |

Power-Outs™ Sets



POWER OUTS & LH DRILL EXTRACTOR SET

| IBS No. | Description |
|---------|---|
| 670P | 5 pc Power Outs & 8 Pc LH Drill Extractor Set (1/16, 1/8, 3/16, 1/4, 5/16, 3/8, 7/16, 1/2) |
| 745R | 5 pc Power Outs Travel Tray w/Corresponding LH Drill Bits (5/32, 1/4 5/16, 7/16 & 1/2) |
| 818R | 5 pc Power Outs Travel Tray w/Corresponding LH Stubby Drill Bits (5/32, 1/4 5/16, 7/16 & 1/2) |

Bolt Extractors

- Reverse spiral flutes are designed to bite down to provide maximum gripping power.
- High carbon steel ensures longer life and greater durability.
- Universal lobular design fits all types of fasteners.
- 3/8 square drive for use with hand ratchets, impact wrenches, and air ratchets.
- Hexagonal flats for use with flat wrench, pliers, adjustable wrench, sockets or locking pliers.



| IBS No. | Description |
|---------|--|
| 54115 | 5 PC 3/8 DRIVE BOLT / STUD EXTRACTOR SET 5/16 - 3/4 Removes bolt sizes: 8mm, 10mm, 13mm, 19mm, 5/16, 11/16, & 3/4" in drive size 3/8" |

Hex Head Spline Drive Screw Extractors

- Designed to remove broken studs, bolts, socket screws and fittings from #12 - 1-3/4".
- For use with sockets and flat wrenches.
- Made in the U.S.A.



25 Piece Hex Head Spline Drive Screw Extractor Set

| IBS No. | Description |
|---------|--|
| 53227 | 25 Pc. Hex Head Spline Drive Screw Extractor Set. Sizes 1/8 - 7/8. Packaged in a sturdy blue plastic box for easy storage and organization |

| IBS No. | Size | Hex Hd Size | Bolt Dia. | Drill Bit |
|---------|-------|-------------|-----------|-----------|
| 53201 | 1/8 | 1/2 | #12 | 1/8 |
| 53202 | 5/32 | 1/2 | 1/4 | 5/32 |
| 53205 | 1/4 | 1/2 | 7/16 | 1/4 |
| 53206 | 9/32 | 1/2 | 1/2 | 9/32 |
| 53207 | 5/16 | 1/2 | 9/16 | 5/16 |
| 53208 | 11/32 | 1/2 | 5/8 | 11/32 |
| 53209 | 3/8 | 1/2 | 11/16 | 3/8 |
| 53210 | 13/32 | 1/2 | 3/4 | 13/32 |
| 53211 | 7/16 | 5/8 | 13/16 | 7/16 |
| 53213 | 1/2 | 5/8 | 15/32 | 1/2 |
| 53216 | 19/32 | 3/4 | 1-1/8 | 19/32 |
| 53217 | 5/8 | 3/4 | 1-3/16 | 5/8 |
| 53220 | 23/32 | 7/8 | 1-3/8 | 23/32 |
| 53225 | 7/8 | 1 | 1-11/16 | 7/8 |



Spiral Screw Extractors

Round shank helical flute screw extractors are used to remove broken screws, bolts, studs, pipe and lubrication fittings without damage to the threaded hole. They are designed with a left hand helical flute to firmly grip and remove any right hand threaded screw or bolt from 3/16 to 3-1/2 in size.



| IBS No. | Size | Drill Size | Diameter of Extractor | | For Screw Sizes | | |
|---------|-----------|------------|-----------------------|--------|-----------------|-------|--|
| | | | Min | Max | Min | Max | |
| 57100 | 1 | 5/64 | .060 | 1/8 | 3/32 | 5/32 | |
| 57110 | 2 | 7/64 | .080 | 3/16 | 5/32 | 7/32 | |
| 57120 | 3 | 5/32 | 1/8 | 1/4 | 7/32 | 9/32 | |
| 57130 | 4 | 1/4 | 3/16 | 5/16 | 9/32 | 3/8 | |
| 57140 | 5 | 17/64 | 1/4 | 7/16 | 3/8 | 5/8 | |
| 57150 | 6 | 13/32 | 3/8 | 5/8 | 5/8 | 7/8 | |
| 57160 | 7 | 17/32 | 15/32 | 7/8 | 7/8 | 1-1/8 | |
| 57170 | 8 | 13/16 | 11/32 | 3/4 | 1-1/8 | 1-3/8 | |
| 57180 | 9 | 1-1/8 | 1 | 1-9/32 | 1-3/8 | 3-1/2 | |
| 16712 | 10 Pc Set | | | | | | |



PN 16712

D R I L L B I T S E T C



D
R
I
L
L
B
I
T
S
E
T
C