



Grease Fittings

G

Grease Fittings

- 1/4"-28 Taper Thread VG-6
 - 1/4" Pipe Thread VG-5, VG-6
 - 1/8" Pipe Thread VG-5
 - Gen'l Information VG-2
 - Drills & Taps Table VG-2
 - Installation VG-2
 - Measuring VG-2
 - Hydraulic Couplers VG-8
 - Lincoln Grease Ftg Coupler VG-8
 - Metric Taper Thread VG-7
 - Metric Thread VG-7
 - Straight VG-6
 - Swivel Coupler VG-8
- #### Tools
- Drive VG-8
 - Easy-Out VG-8
- #### Grease Guns
- Medium Duty VG-9

T

Tools

- Easy-Out Fitting Tools VG-8
- Hydraulic Fitting Tools VG-8

Z

Zerks. See Grease Fittings

**G
R
E
A
S
E

F
I
T
T
I
N
G
S**





IBS, INCORPORATED

Grease Fittings V01

Fitting Measurements

Fittings listed on these pages are shown approximately actual size with the complete dimensional data as indicated at right.

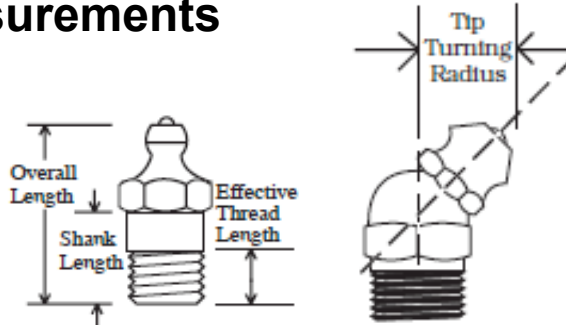

Select Proper Drills & Taps From This Table

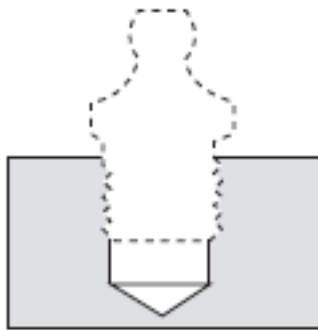

Thread (tap) Size	1/8" Pipe Thread	1/4"-28 Straight or Taper Thread
Drill Size	11/32" (For soft metal use "R" drill)	#3 (For soft metal use #5 drill)

Installation

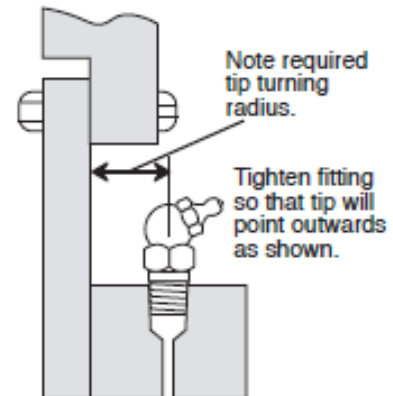
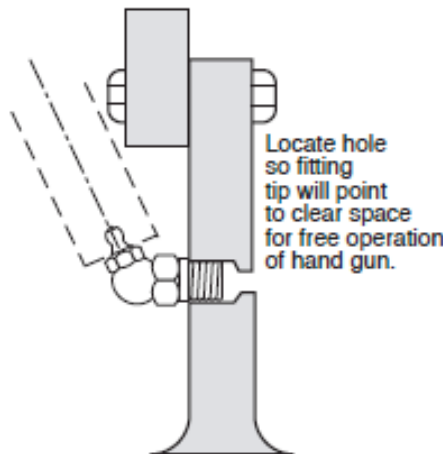
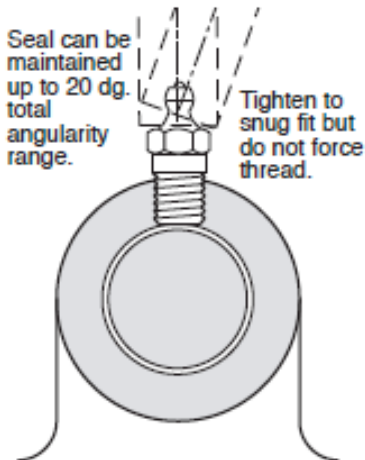

IMPORTANT - The tips of all fittings should be positioned to permit a clear space in a straight line away from fitting for free operation of a hand gun or control valve (seal can be maintained up to 20° total angularity range).

1. Select the proper angle or straight fitting to provide for proper clearance.
2. Be careful in positioning fittings in sub-assemblies to avoid interference from parts of other assemblies.

It is essential that all holes be accurately tapped so that fittings do not have to be screwed in too tight.

1. If original fittings are screwed in too far, the holes will become overly enlarged and service replacements will be difficult.
2. Overtightening, also, can easily strip the threads in soft alloyed metals frequently encountered. Accurate threads and moderate tightening will ensure a leakproof joint.

GREASE FITTINGS



Ball Check Type Grease Fittings

- Ball in tip of fitting keeps out dirt and foreign matter.
- Enlarged inner passage admits more lubricant, helps cut time on important lubrication jobs.
- Balanced action spring retracts easily to allow maximum lubricant flow under pressure, yet holds ball firmly in sealing position at all other times.
- Better coupler connection — Perfect spherical shape of base allows coupler jaws to form leak-proof seal, even at a wide angle.
- Easy installation — All threads accurately machine cut.
- Fitting body made of special hardened steel for long life.
- Accepts all standard makes of hydraulic couplers.
- Universal application — industrial motor equipment.

1/8" Pipe Thread

Fitting Angle	Overall Length (inches)	IBS No.	Qty
Straight, Short	.56	1644-B	25
Straight	.66	1610-B	25
Straight, Long	1.25	1607-B	25
Straight, Long	1.75	1669-B	10
Straight, Long	2.62	1684-B	10
Straight, Female	—	1618-B	25
30°	.90	1611-B	25
30°	2.09	1638-B	10
45°	1.07	1688-B	25
65°	.86	1612-B	25
90°	.84	1613-B	25



1/4" Pipe Thread

Fitting Angle	Overall Length (inches)	IBS No.	Qty
Straight	.88	1627-B	10
67.5°	.97	1629-B	10



- Recommended for heavy lubricants in cold weather.
- Typical application: Large bearings on farm machinery and industrial equipment such as mining equipment and trucks



IBS, INCORPORATED

Grease Fittings V01

1/4"-28 Taper Thread

Fitting Angle	Overall Length	IBS No.	Qty
Tapered Thrd, Straight	.54	1641-B	25
Tapered Thrd, Straight	.69	1652-B	25
Tapered Thrd, Straight	.92	1680-B	25
Tapered Thread 45°	.94	1637-B	25
45° Long Shank	.82	1636-B	25
Tapered Thread 90°	.75	1911-B	25



- Conforms to Society of Automotive Engineers (SAE) lubrication thread specification.
- Small thread size make these fittings very popular for most cars and trucks.

Thread Forming

Fitting Angle	Overall Length	Hole Size	IBS No.	Qty
1/8 Strt, Thrd Cutting	.62	.373 - .380	1720-B	25
1/4-28 Strt, Thrd Cutting	.55	.230 - .235	1652-B	25



Fitting Angle	Overall Length	Hole Size	IBS No.	Qty
5/16-24 UNF - 2A		—	1711-B	25

- Special tapered drive threads reshape the material in an untapped hole to provide a leakproof seal.
- Most effectively installed by spinning into an untapped hole but may also be driven straight into an untapped hole.
- May be replaced by any standard threaded fitting.
- Dyed red for identification.

Drive Fittings

Fitting Angle	Overall Length	IBS No.	Qty
1/8 Straight, No Ball Check		3019-NB	25
3/16 Straight Ball Check		1728-B	25
3/16 45° Ball Check		1646-B	25
1/4 Straight Ball Check		1743-B	25
5/16 Straight Ball Check		1608-B	25
3/8 Straight Ball Check		1666-NB	25



GREASE FITTINGS



IBS, INCORPORATED

Assortments (Z02)



















Grease Fittings Assortment

English Standard

IBS No. 124R 21 Items — 180 Pcs

Packaged in a locking steel drawer for easy storage & organization













 IBS, Inc. <small>SPECIALTY PRODUCTS FOR MAINTENANCE & REPAIR (800) 678-1906 • www.industrialbolt.com</small>		Grease Fittings			
Assortment No. 124R					
1641-B 1/4-28 TAPER TRD STRT ZERK	1652-B 1/4-28 TAPER TRD 11/16 ZERK	1680-B 1/4-28 TAPER TRD 31/32 STRT	1637-B 1/4-28 TAPER TRD 45 DGR ZERK	1911-B 1/4-28 TAPER TRD. 90 DGR ZERK	1610-B 1/8 NPT STRT ZERK
					
1644-B 1/8 NPT SHORT STRT. ZERK	1607-B 1/8 NPT 1-1/4L STRT ZERK	1611-B 1/8 NPT 30DGR STRT ZERK	1688-B 1/8 NPT 45 DGR ZERK	1613-B 1/8 NPT 90DGR ZERK	1629-B 1/4 NPT 67-1/2 DGR ZERK
					
1743-B 1/4 DRIVE ZERK BALL CHECK	1608-B 5/16 DRIVE ZERK BALL CHECK	1728-B 3/16 DRIVE ZERK BALL CHECK	1666-NB 3/8 DRIVE ZERK	1646-B 3/16 45DGR DRIVE ZERK	
					
1711-B 5/16-24 ZERK (LEAF SPRINGS)	1720-B 1/8 NPT STRT THREAD CUTTING	3038-B 1/4-28 NPT STRT THREAD CUTTING	5251 RUBBER ZERK CAP		
					

Grease Fittings Assortment

English Standard

IBS No. 225R 12 Items — 178 pcs

Packaged in a locking steel drawer for easy storage & organization

 IBS, Inc. <small>SPECIALTY PRODUCTS FOR MAINTENANCE & REPAIR (800) 678-1906 • www.industrialbolt.com</small>		Grease Fittings			
Assortment No. 225R					
1641-B 1/4-28 TAPER TRD STRT ZERK	1652-B 1/4-28 TAPER TRD 11/16 ZERK	1637-B 1/4-28 TAPER TRD 45 DGR ZERK	1911-B 1/4-28 TAPER TRD. 90 DGR ZERK		
					
1610-B 1/8 NPT STRT ZERK	1688-B 1/8 NPT 45 DGR ZERK	1613-B 1/8 NPT 90DGR ZERK			
					
1608-B 5/16 DRIVE ZERK BALL CHECK	1728-B 3/16 DRIVE ZERK BALL CHECK				
					
5251 RUBBER ZERK CAP				308730 1/8 NPT GREASE FITTING COUPLER	
					

GREASE FITTINGS





IBS, INCORPORATED

Grease Fittings V01

GREASE FITTINGS

Metric Fittings

6mm x 1mm (pitch)

Fitting Angle	Length (inches)	IBS No.	Qty
Tapered Thrd, Straight	.63	Z-1600	25
Tapered Thrd, 45°	.82	Z-1621	25
Tapered Thrd, 90°	.71	Z-1690	25



Z-1600



Z-1621



Z-1690

8mm x 1mm (pitch)

Fitting Angle	Length (inches)	IBS No.	Qty
Tapered Thrd, Straight	.63	Z-2103	25
Tapered Thrd, 45°	.82	Z-2104	25
Tapered Thrd, 90°	.71	Z-2105	25



Z-2103



Z-2104



Z-2105

10mm x 1mm (pitch)

Fitting Angle	Length (inches)	IBS No.	Qty
Tapered Thrd, Straight	.63	Z-2109	25
Tapered Thrd, 45°	.82	Z-2110	25
Tapered Thrd, 90°	.71	Z-2111	25



Z-2109



Z-2110



Z-2111

Rubber Zerk Cap

- Rubber caps slip easily on and off grease fitting.
- Protects grease fitting against dirt, rocks, chemicals and impact from other sources.
- Reusable.



IBS No.	Description	Qty
5251	Rubber Zerk Cap	25



IBS, INCORPORATED

Assortments (Z02)



Metric Grease Fittings Assortment

IBS No. 232R • 10 Items - 175 pcs

Packaged in a locking steel drawer for easy storage & organization

 IBS, Inc. <small>SPECIALTY PRODUCTS FOR MAINTENANCE & REPAIR (800) 678-1906 • www.industrialbolt.com</small>		Metric Grease Fittings	
Assortment No. 232R			
Z-1600 6MM X 1.0 STRT METRIC ZERK 	Z-1621 6MM X 1.0 45DGR METRIC ZERK 	Z-1690 6MM X 1.0 90DGR METRIC ZERK 	
Z-2103 8MM X 1.0 STRT METRIC ZERK 	Z-2104 8MM X 1.0 45DGR METRIC ZERK 	Z-2105 8MM X 1.0 90DGR METRIC ZERK 	
Z-2109 10MM X 1.0 STRT. METRIC ZERKS 	Z-2110 10MM X 1.0 45DGR METRIC ZERK 	Z-2111 10MM X 1.0 90DGR METRIC ZERK 	
5251 RUBBER ZERK CAP 			

GREASE FITTINGS





IBS, INCORPORATED

Grease Fittings V01

GREASE FITTINGS

Hydraulic Couplers



- Provides quick, positive leak-proof connection with hydraulic fittings.
- Grease pressure forces 3 hardened steel jaws against the fitting.

IBS No.	Description	Thread	Qty
308730	Straight Coupler	1/8" NPTF	5

Swivel Coupler



- Coupler swivels a full 360°.
- Locks in any of eight positions.
- Ideal for engaging out-of-the-way fittings.
- Use 1/8" NPTF pipe extension to connect coupler to gun outlet.
- Narrow diameter coupler.
- Rubber seal.

IBS No.	Description	Thread	Qty
6509-E	Swivel Coupler	1/8" NPTF	1

Lincoln Grease Ftg Coupler

- 6,000 psi maximum operating pressure
- For all hydraulic grease fittings
- Small outside diameter permits easy contact with recessed fittings
- Replaceable hardened steel jaws
- Built-in ball check prevents leak and lubricant back up.



IBS No.	Description	Thread	Qty
5852	Lincoln Coupler	1/8" NPTF	1

Hydraulic Fitting Tools

Tools For Straight and Angle-type Drive Fittings



5253

IBS No.	For Drive Fittings	Qty
5253	1666-NB, 1743B, 3019NB	1
5253-1	1608-B, 1743B	1
5253-2	1728B	1

Easy-Out Fitting Tools

Extract broken fittings, rethread holes and install fittings with one tool.



B315790



B315791

IBS No.	For Fittings with Thread	Qty
B315790	14-28" Taper Thread	1
B315791	18" NPT	1

Flex Lubricator Extension Hose

For Lever & Screw-Type Hand Guns

- End connections are 1/8" NPTF (m).
- Maximum working pressure: 4800 psi.
- Minimum burst pressure: 12,000 psi.



317850-1



317850-1F

IBS No.	Description	Qty
317850-1	12" Length	1
317850-1F	18" Length	1





Medium Duty Grease Guns



500HD

- Develops pressure up to 10,000 psi.
- Automatic variable pressure.
- Deliver: 1 ounce per 21 strokes
- Air vent fitting.
- Vinyl grip.
- Deluxe pull handle with heavy duty rivets and positive stop.
- Heavy-duty one-piece head.
- Three-way loader -fitting included.

IBS No.	Description	Qty
500HD	Grease Gun	1



525HD

- Three-way loading - Loader fitting included.
- 4500/3000 psi.
- Automatic variable pressure.
- Delivery — 1 Oz. per 33, 16 strokes.
- Air vent fitting.
- Vinyl grip.
- Deluxe pull handle with heavy duty rivets.
- Heavy duty one-piece head.

IBS No.	Description	Qty
525HD	Grease Gun	1



25704

- Heavy duty aluminum cast head.
- Pistol grip action for one handed operation.
- Locking plunger for safe easy loading.
- Cast aluminum T-Handle for non-slip grip.

IBS No.	Description	Qty
525HD	Grease Gun	1

**G
R
E
A
S
E

F
I
T
T
I
N
G
S**





IBS, INCORPORATED

Grease Fittings V01

G
R
E
A
S
E

F
I
T
T
I
N
G
S

LockNLube Coupler

The LockNLube Coupler has a unique sliding sleeve, activated by thumb lever. The sleeve either locks the four spring-steel jaws onto the zerk fitting or releases the jaws from the zerk. No hands are needed to align or hold the coupler in place while greasing. The locked connection is positive and rigid, preventing the coupler from coming loose and breaking the leakproof seal. If a fitting becomes pressurized, especially a recessed one, just depress the thumb lever and release the coupler. Because it does not leak, the grease goes in, not on the machine, and the bearings get the grease they so desperately need.



- Works with all grease gun types: pneumatic, manual and electric.
- Works on all DIN and SAE specification zerks.
- Fits 1/8" pipe thread.
- Works with all grease gun manufacturers.
- No need to hold while greasing. Lock-on and free up both hands to operate the grease gun. — simply depress the trigger to release, even under pressure.
- Durable nitrile rubber seal for longevity under high pressure.
- Four hardened spring steel jaws are resilient under high pressure.
- Check valve to reduce leakage.
- LOCKNLUBE XL with a longer barrel has a 3.6" effective reach.

LOCKNLUBE GREASE COUPLER

IBS No.	Description	Qty
5855	LockNLube Locking Grease Coupler	1
5856	LockNLube XL Locking Grease Coupler	1
5860	LockNLube Repair Kit	1

VG-10



"The mark of our quality is in our service"

09-12-17