



Capscrews

A

Assortments

Grade 5

- Coarse Thread - 40 Items A-40, A-41
- Coarse Thread - 72 Items A-38, A-39
- Fine Thread - 40 Items A-45, A-46
- Fine Thread - 72 Items A-43, A-44

Grade 8

- Coarse Thread - 40 Items A-23, A-24
- Coarse Thread - 72 Items A-21, A-22
- Coarse Thread - Plated - 40 Items A-29, A-30
- Coarse Thread - Zinc Yellow Plated 72B A-27, A-28
- Fine Thread - 72 Items A-32, A-33
- Fine Thread - Plated 40 Items A-34, A-35

Hi-Alloy

- Fine Thread - 72 Items A-15, A-16

C

Capscrews

Grade 5 A-36

- N.C. 1/4 - 1/2 A-37
- N.F. 1/4 - 1/2 A-42

Grade 8 A-17

- N.C. 1/2 - 3/4 A-19
- N.C. 1/4 - 7/16 A-18
- N.C. 7/8 — 1-1/2 A-20
- N.F. 9/16 - 1 A-31

Grade 8 - Plated

- N.C. 1/4 - 1/2 A-25
- N.C. 9/16 - 1 A-26

High-Alloy A-4

- N. C. 1/4 - 1/2 A-7
- N. C. 9/16 - 1 A-8
- N. F. 1/4 - 1/2 A-13
- N.F. 9/16 - 1 A-14

F

Fasteners

Flange Bolts, Grade 8

- Fine A-49

General Information

- Grade 5 Hex Capscrews A-36
- Grade 8 Flange Bolts A-47
- Grade 8 Heat Treated Hex Capscrews A-17
- High-Alloy Fastening System A-4, A-5
- Thread Pitch Chart - National Coarse A-2
- Thread Pitch Chart - National Fine A-3

Grade 8 Capscrews

- Fine A-31

Grade 8 Capscrews - Plain

Coarse A-18, A-19, A-20

Grade 8 Capscrews - Plated

Coarse A-25, A-26

High Alloy Capscrews

Coarse A-8

High-Alloy Capscrews

Coarse A-7

Fine A-13, A-14

Flange Bolts

Grade 8 A-47

N.C. 3/8 - 3/4 A-49

N.F. 1/2 - 5/8 A-49

T

Thread Pitch Chart - National Coarse A-2

Thread Pitch Chart - National Fine A-3

C
A
P
S
C
R
E
W
S



Thread Pitch Chart - National Coarse

C
A
P
S
C
R
E
W
S

1/4-20



7/8-9

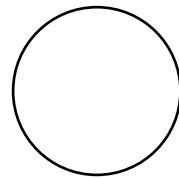
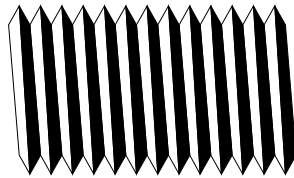

5/16-18



1 - 8

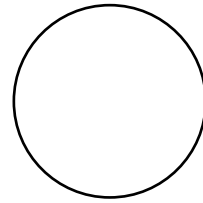
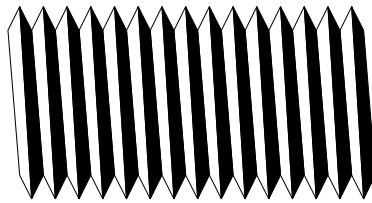

3/8-16



7/16-14



1-1/8 - 7

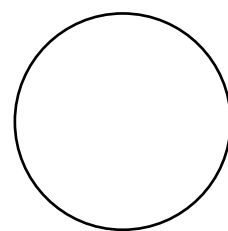
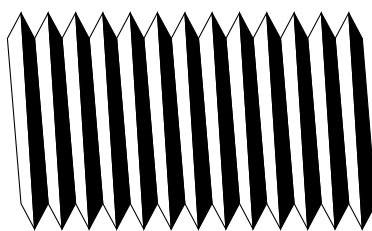

1/2-13

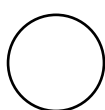

1-1/4 7-

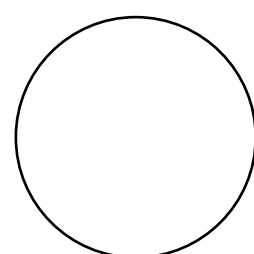
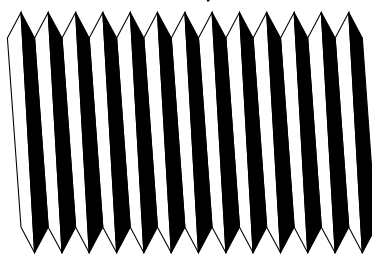

9/16-12

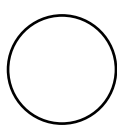

5/8-11

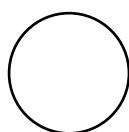
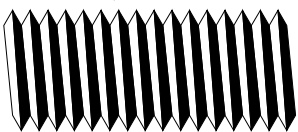

1-1/2 - 6

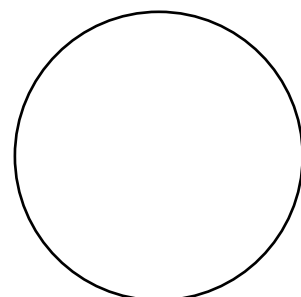
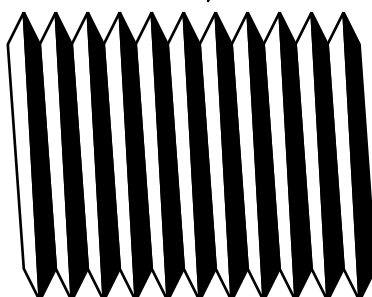

3/4-10

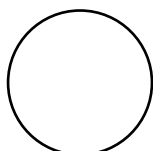
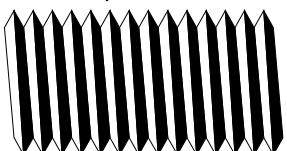



Thread Pitch Chart - National Fine

1/4-28



3/4-16

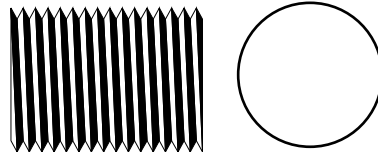

5/16-24



7/8-14

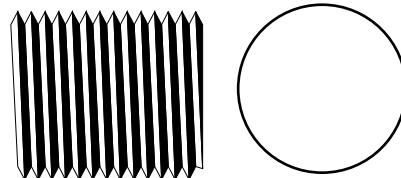

7/16-~~2~~2



1 -14

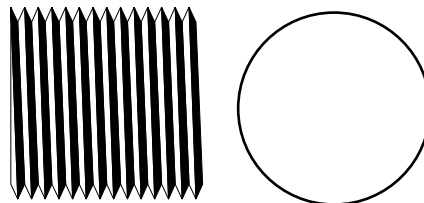

1/2-~~2~~2

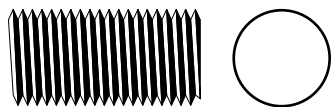

9/16-18

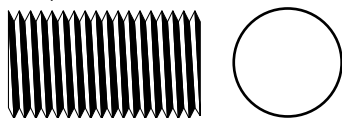

1-1/4 -12

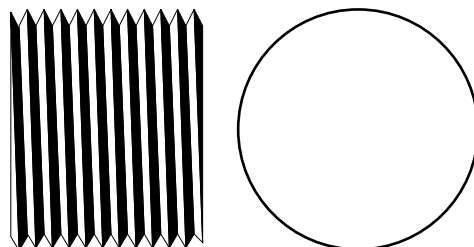

5/8-18

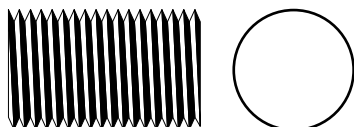

C
A
P
S
C
R
E
W
S



IBS, INCORPORATED

Hi-Alloy Fastening System Gen'l Info

High-Alloy Fastening System

HIGH-ALLOY products are manufactured from special AISI alloy steels and undergo critically monitored heat treatments. This is done in order to provide the strongest off-the-shelf fastening system available. The HIGH-ALLOY fastening system is designed and engineered for use in high stress, severe service environments.

The HIGH-ALLOY fastening system is designed for 180,000 to 200,000 psi ultimate tensile strength and having the minimum ductility of SAE J429 Grade 8 bolts for reduction in area and elongation.

The High-Alloy fastening system is engineered and carefully manufactured to operate as a system consisting of a bolt, two washers (two styles available) and either a hex nut or a prevailing torque locknut. Each of these components contributes to the optimum performance and maximum reliability of the system.

C
A
P
S
C
R
E
W
S

Thicker than standard bolt head adds wrenching surface.

Washer face eliminates corner drag.

Radius under bolt head adds strength.

Countersunk washer I.D. centers the washer against the bolt head bearing surface during tightening.

UNR radiused root bolt thread increases fatigue resistance by reducing the notch effect of conventional UN threads. The UNR thread radius is maintained into the thread runout at the junction of thread to shank.

Smooth washer bearing surfaces distribute loads uniformly and reduce brinelling. Plated finish assists torquing.

Chamfers eliminate corner drag.

Thicker than standard nut side walls facilitate wrenching.

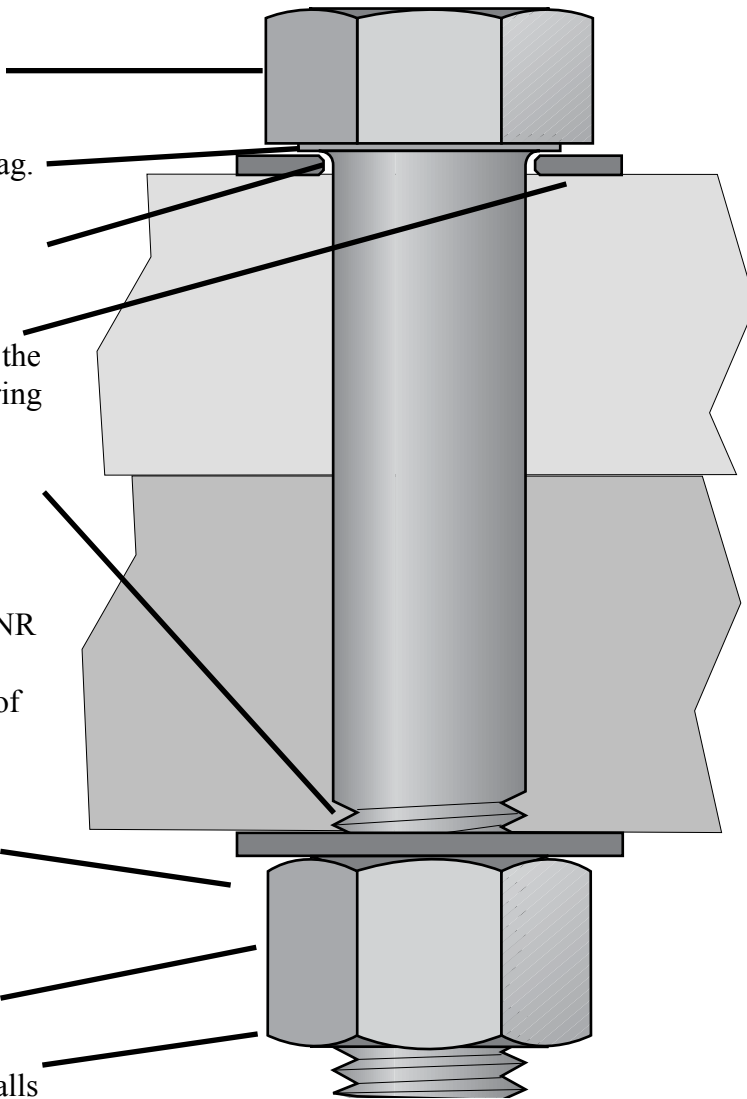



High-Alloy Fastening System Clamp Load

Assuming that the joint has been designed properly and the right fastener has been selected, bolts which are correctly tightened to required clamp loads rarely fail in service. Locknuts can preserve clamp loads by inhibiting loosening and nut backoff due to vibration. Clamp loads must exceed the maximum static or dynamic external loads that will be applied to the joint otherwise the fastener or joint may fail.

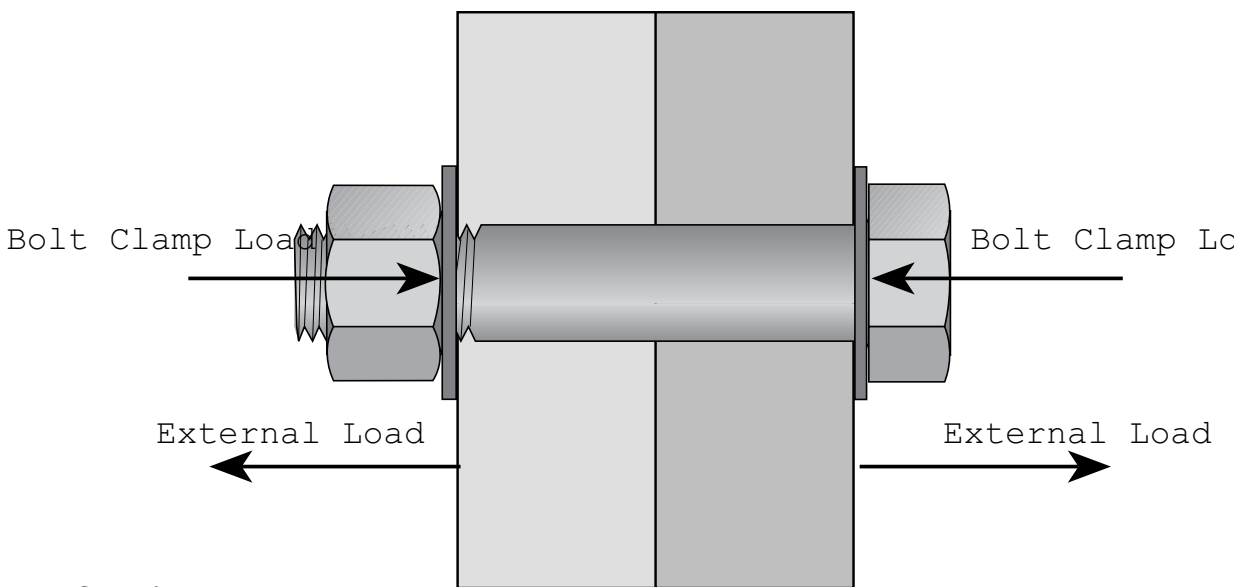

User Cautions:

Avoid fastener, and possible joint failure, by observing the following:

- 1) Do not substitute components in the High-Alloy fastening system. Non High-Alloy may not meet the system's requirements. IBS is not responsible for any failures in use of High-Alloy fastening system if substitutions are made of any component or finish of the system (i.e. bolt, nut, locknut or washer).
- 2) Do not alter the coatings as this can result in erratic and unpredictable clamploads. Do not use supplementary lubricants.
- 3) Do not use the High-Alloy system in service environments exceeding 400°F. Any cadmium or zinc plated product is subject to degradation of corrosion resistance and possible liquid metal embrittlement at temperatures exceeding 400°F.
- 4) Discuss the use of High-Alloy bolts and washers in tapped holes with your IBS Rep. to establish correct tightening torques and methods. Excessive or insufficient clamp loads can cause major problems.
- 5) When tightening High-Alloy bolts, use the recommended torque values. The self lubricating features of the system reduce required torques so that in some instances they are below those needed to tighten Grade 8 bolts.

THE HIGH-ALLOY FASTENING SYSTEM IS DESIGNED AND MANUFACTURED TO BE USED AS A SYSTEM. NO SUBSTITUTIONS OR ALTERATIONS ARE TO BE MADE OF THE BOLT, NUT, WASHER OR FINISH.



IBS, INCORPORATED

Hi-Alloy Fastening System Gen'l Info

High-Alloy Fastening System Benefits

- 180,000 psi tensile strength is 20% greater than Grade 8.
- Can last 10 to 20 times as long as Grade 8 fasteners.
- Ductility equals or exceeds Grade 8.
- Greatly reduces down time.
- Reduces maintenance time and costs.
- Improved product performance.
- Lower mechanical failure costs.
- Bolts are zinc-plated and dichromate-coated to improve lubrication for controlled tightening and to inhibit corrosion. This reduces the torque needed to develop recommended high clamp loads and produces a 96-hour salt spray resistance to corrosion.

High-Alloy System Hardness Specifications

Product	Diameter Range	Rockwell Hardness
Bolts	All	R/C 38-42
Nuts	1/4 thru 5/8	R/C 28-34
	3/4 thru 1-1/2	R/C 32-38
Washers	All	15N 82-85

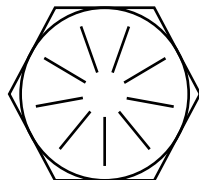

High-Alloy Bolt Head Marking

ALL HIGH-ALLOY BOLTS, NUTS AND WASHERS ARE TRACEABLE TO THEIR ORIGINAL PRODUCTION LOT. SAMPLES OF EACH LOT ARE KEPT ON FILE, WITH ALL DOCUMENTATION REGARDING BATCH DATE, QUALITY CONTROL INSPECTIONS AND TEST REPORTS.

C
A
P
S
C
R
E
W
S



IBS, INCORPORATED

Hi-Alloy Capscrews Nat'l Coarse A01



USS High-Alloy Capscrews

NATIONAL COARSE — PLATED ZINC YELLOW



Length	1/4-20 IBS No.	5/16-18 IBS No.	3/8-16 IBS No.	Qty	7/16-14 IBS No.	1/2-13 IBS No.	Qty	Length
1/2	101	116	—	100	—	—	—	1/2
3/4	102	117	136	100	—	172	50	3/4
1	103	118	137	100	155	173	50	1
1-1/4	104	119	138	100	156	174	50	1-1/4
1-1/2	105	120	139	100	157	175	50	1-1/2
1-3/4	106	121	140	100	158	176	50	1-3/4
2	107	122	141	100	159	177	50	2
2-1/4	108	123	142	50	160	178	25	2-1/4
2-1/2	109	124	143	50	161	179	25	2-1/2
2-3/4	110	125	144	50	162	180	25	2-3/4
3	111	126	145	25	163	181	25	3
3-1/2	113	128	147	25	165	183	25	3-1/2
4	115	130	149	25	167	185	25	4
4-1/2	115A	131	150	15	168	186	10	4-1/2
5	115D	132	151	15	—	187	10	5
5-1/2	—	—	152	15	171	188	10	5-1/2
6	—	134	153	15	171A	189	10	6
6-1/2	—	—	—	—	—	189A	EA	6-1/2
7	—	—	—	—	—	190	EA	7
7-1/2	—	—	—	—	—	—	EA	7-1/2
8	—	—	—	—	—	191	EA	8

THE HIGH-ALLOY FASTENING SYSTEM IS DESIGNED AND MANUFACTURED TO BE USED AS A SYSTEM. NO SUBSTITUTIONS OR ALTERATIONS ARE TO BE MADE OF THE BOLT, NUT, WASHER OR FINISH.

**C
A
P
S
C
R
E
W
S**



IBS, INCORPORATED

Hi-Alloy Capscrews Nat'l Coarse A01



USS High Alloy Capscrews

NATIONAL COARSE — PLATED ZINC YELLOW

Length	9/16-12 IBS No.	5/8-11 IBS No.	Qty	3/4-10 IBS No.	Qty	7/8-9 IBS No.	Qty	1 - 8 IBS No.	Qty	Length
1	195	215	25	244	20	—	—	—	—	1
1-1/4	196	216	25	244A	20	—	—	—	—	1-1/4
1-1/2	197	217	25	245	20	273	15	299A	EA	1-1/2
1-3/4	198	218	25	246	20	274	15	299B	EA	1-3/4
2	199	219	25	247	20	275	15	300	EA	2
2-1/4	200	220	25	248	10	276	10	301	EA	2-1/4
2-1/2	201	221	25	249	10	277	10	302	EA	2-1/2
2-3/4	202	222	25	250	10	278	10	302A	EA	2-3/4
3	203	223	25	251	10	279	10	303	EA	3
3-1/2	205	225	25	253	10	281	10	304	EA	3-1/2
4	207	227	25	255	10	283	10	305	EA	4
4-1/2	208	228	10	256	5	284	5	306	EA	4-1/2
5	209	229	10	257	5	285	5	307	EA	5
5-1/2	210	230	10	258	5	286	5	308	EA	5-1/2
6	211	231	10	259	5	287	5	309	EA	6
6-1/2	—	232	EA	260	EA	288	EA	310	EA	6-1/2
7	—	233	EA	261	EA	289	EA	311	EA	7
7-1/2	—	234	EA	262	EA	290	EA	312	EA	7-1/2
8	—	235	EA	263	EA	291	EA	313	EA	8
8-1/2	—	236	EA	264	EA	292	EA	314	EA	8-1/2
9	—	237	EA	265	EA	293	EA	315	EA	9
9-1/2	—	238	EA	266	EA	294	EA	316	EA	9-1/2
10	—	239	EA	267	EA	295	EA	317	EA	10

THE HIGH-ALLOY FASTENING SYSTEM IS DESIGNED AND MANUFACTURED TO BE USED AS A SYSTEM. NO SUBSTITUTIONS OR ALTERATIONS ARE TO BE MADE OF THE BOLT, NUT, WASHER OR FINISH.

C
A
P
S
C
R
E
W
S





High Alloy Assortment

COARSE THREAD — PLATED ZINC YELLOW

IBS No. 890P • USS • 72 Items - 1,637 Pieces

USS Hi-Alloy Bolts, SAE Hi-Alloy Flat Washers

USS Hi-Alloy Finished Nuts, USS Hi-Alloy Locknuts

- 180,000 psi tensile strength.
- Can last 10 to 20 times longer than Grade 8.

890P • HI ALLOY ASSORTMENT • 72 Items

1/4-20 Hex Nut	5/16-18 Hex Nut	3/8-16 Hex Nut	7/16-14 Hex Nut	1/2-13 Hex Nut	9/16-12 Hex Nut	5/8-11 Hex Nut	3/4-13 Hex Nut
NT5202	NT5204	NT5206	NT5208	NT5212	NT5214	NT5216	NT5218
1/4 SAE FW	5/16 SAE FW	3/8 SAE FW	7/16 SAE FW	1/2 SAE FW	9/16 SAE FW	5/8 SAE FW	3/4 SAE FW
7400	7401	7402	7403	7404	7405	7406	7407
1/4 Lock Nut	5/16 Lock Nut	3/8 Lock Nut	7/16 Lock Nut	1/2 Lock Nut	9/16 Lock Nut	5/8 Lock Nut	3/4 Lock Nut
4400	4401	4402	4403	4404	4405	4406	4407
Open Stock	Open Stock	Open Stock	Open Stock	Open Stock	Open Stock	Open Stock	Open Stock
1/4 x 3/4 Capscrew	5/16 x 3/4 Capscrew	3/8 x 3/4 Capscrew	7/16 x 1 Capscrew	1/2 x 1 Capscrew	9/16 x 1-1/4 Capscrew	5/8 x 1-1/4 Capscrew	3/4 x 1-1/2 Capscrew
102	117	136	155	173	196	216	245
1/4 x 1 Capscrew	5/16 x 1 Capscrew	3/8 x 1 Capscrew	7/16 x 1-1/4 Capscrew	1/2 x 1-1/4 Capscrew	9/16 x 1-1/2 Capscrew	5/8 x 1-1/2 Capscrew	3/4 x 1-3/4 Capscrew
103	118	137	156	174	197	217	245
1/4 x 1-1/4 Capscrew	5/16 x 1-1/4 Capscrew	3/8 x 1-1/4 Capscrew	7/16 x 1-1/2 Capscrew	1/2 x 1-1/2 Capscrew	9/16 x 1-3/4 Capscrew	5/8 x 1-3/4 Capscrew	3/4 x 2 Capscrew
104	119	138	157	175	198	218	246
1/4 x 1-1/2 Capscrew	5/16 x 1-1/2 Capscrew	3/8 x 1-1/2 Capscrew	7/16 x 1-3/4 Capscrew	1/2 x 1-3/4 Capscrew	9/16 x 2 Capscrew	5/8 x 2 Capscrew	3/4 x 2-1/2 Capscrew
105	120	139	158	176	199	219	247
1/4 x 1-3/4 Capscrew	5/16 x 1-3/4 Capscrew	3/8 x 2 Capscrew	7/16 x 2 Capscrew	1/2 x 2 Capscrew	9/16 x 2-1/2 Capscrew	5/8 x 2-1/2 Capscrew	3/4 x 3 Capscrew
106	121	141	159	177	201	221	251
1/4 x 2 Capscrew	5/16 x 2 Capscrew	3/8 x 2-1/2 Capscrew	7/16 x 2-1/2 Capscrew	1/2 x 2-1/2 Capscrew	9/16 x 3 Capscrew	5/8 x 3 Capscrew	3/4 x 3-1/2 Capscrew
107	122	143	161	179	203	223	253

C
A
P
S
C
R
E
W
S



IBS, INCORPORATED

Bin Assortments Z06

High Alloy Assortment

COARSE THREAD — PLATED ZINC YELLOW

IBS No. 891P • USS • 72 Items - 1,637 Pieces

USS Hi-Alloy Bolts, USS Hi-Alloy Flat Washers

USS Hi-Alloy Finished Nuts, USS Hi-Alloy Locknuts



- 180,000 psi tensile strength.
- Can last 10 to 20 times longer than Grade 8.

891P • HI ALLOY ASSORTMENT • 72 Items

1/4-20 Hex Nut	5/16-18 Hex Nut	3/8-16 Hex Nut	7/16-14 Hex Nut	1/2-13 Hex Nut	9/16-12 Hex Nut	5/8-11 Hex Nut	3/4-10 Hex Nut
NT5202	NT5204	NT5206	NT5208	NT5212	NT5214	NT5216	NT5218
1/4 USS FW	5/16 USS FW	3/8 USS FW	7/16 USS FW	1/2 USS FW	9/16 USS FW	5/8 USS FW	3/4 USS FW
7016	7017	7018	7019	7020	7021	7022	7023
1/4 Lock Nut	5/16 Lock Nut	3/8 Lock Nut	7/16 Lock Nut	1/2 Lock Nut	9/16 Lock Nut	5/8 Lock Nut	3/4 Lock Nut
NT9403	NT9405	NT9407	NT9409	NT9413	NT9415	NT9417	NT9419
Open Stock	Open Stock	Open Stock	Open Stock	Open Stock	Open Stock	Open Stock	Open Stock
1/4 x 3/4 Capscrew	5/16 x 3/4 Capscrew	3/8 x 3/4 Capscrew	7/16 x 1 Capscrew	1/2 x 1 Capscrew	9/16 x 1-1/4 Capscrew	5/8 x 1-1/4 Capscrew	3/4 x 1-1/2 Capscrew
102	117	136	155	173	196	216	245
1/4 x 1 Capscrew	5/16 x 1 Capscrew	3/8 x 1 Capscrew	7/16 x 1-1/4 Capscrew	1/2 x 1-1/4 Capscrew	9/16 x 1-1/2 Capscrew	5/8 x 1-1/2 Capscrew	3/4 x 1-3/4 Capscrew
103	118	137	156	174	197	217	246
1/4 x 1-1/4 Capscrew	5/16 x 1-1/4 Capscrew	3/8 x 1-1/4 Capscrew	7/16 x 1-1/2 Capscrew	1/2 x 1-1/2 Capscrew	9/16 x 1-3/4 Capscrew	5/8 x 1-3/4 Capscrew	3/4 x 2 Capscrew
104	119	138	157	175	198	218	247
1/4 x 1-1/2 Capscrew	5/16 x 1-1/2 Capscrew	3/8 x 1-1/2 Capscrew	7/16 x 1-3/4 Capscrew	1/2 x 1-3/4 Capscrew	9/16 x 2 Capscrew	5/8 x 2 Capscrew	3/4 x 2-1/2 Capscrew
105	120	139	158	176	199	219	249
1/4 x 1-3/4 Capscrew	5/16 x 1-3/4 Capscrew	3/8 x 2 Capscrew	7/16 x 2 Capscrew	1/2 x 2 Capscrew	9/16 x 2-1/2 Capscrew	5/8 x 2-1/2 Capscrew	3/4 x 3 Capscrew
106	121	141	159	177	201	221	251
1/4 x 2 Capscrew	5/16 x 2 Capscrew	3/8 x 2-1/2 Capscrew	7/16 x 2-1/2 Capscrew	1/2 x 2-1/2 Capscrew	9/16 x 3 Capscrew	5/8 x 3 Capscrew	3/4 x 3-1/2 Capscrew
107	122	143	161	179	203	223	253

C
A
P
S
C
R
E
W
S

IBS, INCORPORATED

Assortments Z08



High Alloy Assortment

COARSE THREAD — PLATED ZINC YELLOW

IBS No. 437P • 40 Items - 965 Pieces

USS Hi-Alloy Bolts, SAE Hi-Alloy Flat Washers

USS Hi-Alloy Finished Nuts, USS Hi-Alloy Locknuts

- 180,000 psi tensile strength.
- Can last 10 to 20 times longer than Grade 8.

437P • HI ALLOY ASSORTMENT • 40 Items

1/4-20 Hex Nut NT5202	1/4-20 Lock Nut NT9403	1/4 SAE FW 7400	1/4 x 3/4 Capscrew 102	1/4 x 1 Capscrew 103	1/4 x 1-1/4 Capscrew 104	1/4 x 1-1/2 Capscrew 105	1/4 x 2 Capscrew 107
5/16-18 Hex Nut NT5204	5/16-18 Lock Nut NT9405	5/16 SAE FW 7401	5/16 x 3/4 Capscrew 117	5/16 x 1 Capscrew 118	5/16 x 1-1/4 Capscrew 119	5/16 x 1-1/2 Capscrew 120	5/16 x 2 Capscrew 122
3/8-16 Hex Nut NT5206	3/8-16 Lock Nut NT9407	3/8 SAE FW 7402	3/8 x 1 Capscrew 137	3/8 x 1-1/4 Capscrew 138	3/8 x 1-1/2 Capscrew 139	3/8 x 2 Capscrew 141	3/8 x 2-1/2 Capscrew 143
7/16-14 Hex Nut NT5208	5/16-18 Lock Nut NT9409	7/16 SAE FW 7403	7/16 x 1 Capscrew 155	7/16 x 1-1/4 Capscrew 156	7/16 x 1-1/2 Capscrew 157	7/16 x 2 Capscrew 159	7/16 x 2-1/2 Capscrew 161
1/2-13 Hex Nut NT5212	1/2-13 Lock Nut NT9413	1/2 SAE FW 7404	1/2 x 1 Capscrew 173	1/2 x 1-1/4 Capscrew 174	1/2 x 1-1/2 Capscrew 175	1/2 x 2 Capscrew 177	1/2 x 2-1/2 Capscrew 179

C
A
P
S
C
R
E
W
S



IBS, INCORPORATED

Assortments Z08



High Alloy Assortment

COARSE THREAD — PLATED ZINC YELLOW

IBS No. 654P • 40 Items - 965 Pieces

USS Hi-Alloy Bolts, USS Hi-Alloy Flat Washers

USS Hi-Alloy Finished Nuts, USS Hi-Alloy Locknuts

- 180,000 psi tensile strength.
- Can last 10 to 20 times longer than Grade 8.

654P • HI ALLOY ASSORTMENT • 40 Items

1/4-20 Hex Nut NT5202	1/4-20 Lock Nut NT9403	1/4 USS FW 7016	1/4 x 3/4 Capscrew 102	1/4 x 1 Capscrew 103	1/4 x 1-1/4 Capscrew 104	1/4 x 1-1/2 Capscrew 105	1/4 x 2 Capscrew 107
5/16-18 Hex Nut NT5204	5/16-18 Lock Nut NT9405	5/16 USS FW 7017	5/16 x 3/4 Capscrew 117	5/16 x 1 Capscrew 118	5/16 x 1-1/4 Capscrew 119	5/16 x 1-1/2 Capscrew 120	5/16 x 2 Capscrew 122
3/8-16 Hex Nut NT5206	3/8-16 Lock Nut NT9407	3/8 USS FW 7018	3/8 x 1 Capscrew 137	3/8 x 1-1/4 Capscrew 138	3/8 x 1-1/2 Capscrew 139	3/8 x 2 Capscrew 141	3/8 x 2-1/2 Capscrew 143
7/16-14 Hex Nut NT5208	5/16-18 Lock Nut NT9409	7/16 USS FW 7019	7/16 x 1 Capscrew 155	7/16 x 1-1/4 Capscrew 156	7/16 x 1-1/2 Capscrew 157	7/16 x 2 Capscrew 159	7/16 x 2-1/2 Capscrew 161
1/2-13 Hex Nut NT5212	1/2-13 Lock Nut NT9413	1/2 USS FW 7020	1/2 x 1 Capscrew 173	1/2 x 1-1/4 Capscrew 174	1/2 x 1-1/2 Capscrew 175	1/2 x 2 Capscrew 177	1/2 x 2-1/2 Capscrew 179

C
A
P
S
C
R
E
W
S

IBS, INCORPORATED

Hi-Alloy Capscrews Nat'l Fine A02



SAE High-Alloy Capscrews

NATIONAL FINE — ZINC YELLOW



Length	1/4-28 IBS No.	5/16-24 IBS No.	3/8-24 IBS No.	Qty	7/16-20 IBS No.	1/2-20 IBS No.	Qty	Length
1/2	325	345	364	100	—	—	—	1/2
3/4	326	346	365	100	—	404	50	3/4
1	327	347	366	100	386	405	50	1
1-1/4	328	348	367	100	387	406	50	1-1/4
1-1/2	329	349	368	100	388	407	50	1-1/2
1-3/4	330	350	369	100	389	408	50	1-3/4
2	331	351	370	100	390	409	50	2
2-1/4	332	352	371	50	391	410	25	2-1/4
2-1/2	333	353	372	50	392	411	25	2-1/2
2-3/4	334	354	373	50	394	412	25	2-3/4
3	335	355	374	25	395	413	25	3
3-1/2	337	357	376	25	397	415	25	3-1/2
4	339	359	378	25	399	417	25	4
4-1/2	340	360	379	15	400	418	10	4-1/2
5	341	361	380	15	401	419	10	5
5-1/2	—	—	381	15	402	420	10	5-1/2
6	—	—	382	15	403	421	10	6
6-1/2	—	—	—	—	—	422	EA	6-1/2

**C
A
P
S
C
R
E
W
S**

THE HIGH-ALLOY FASTENING SYSTEM IS DESIGNED AND MANUFACTURED TO BE USED AS A SYSTEM. NO SUBSTITUTIONS OR ALTERATIONS ARE TO BE MADE OF THE BOLT, NUT, WASHER OR FINISH.



IBS, INCORPORATED

Hi-Alloy Capscrews Nat'l Fine A02



SAE High-Alloy Capscrews

NATIONAL FINE — ZINC YELLOW

Length	9/16-18 IBS No.	5/8-18 IBS No.	Qty	3/4-16 IBS No.	Qty	7/8-14 IBS No.	Qty	1 - 14 IBS No.	Qty	Length
1	430	450	25	475	20	—	—	—	—	1
1-1/4	431	451	25	476	20	—	—	—	—	1-1/4
1-1/2	432	452	25	477	20	—	—	—	—	1-1/2
1-3/4	433	453	25	478	20	—	—	—	—	1-3/4
2	434	454	25	479	20	500	15	516	EA	2
2-1/4	435	455	25	480	10	—	—	—	—	2-1/4
2-1/2	436	456	25	481	10	503	10	517	EA	2-1/2
2-3/4	437	457	25	482	10	—	—	—	—	2-3/4
3	438	458	25	483	10	504	10	518	EA	3
3-1/2	440	460	25	485	10	504A	10	519	EA	3-1/2
4	442	462	25	487	10	505	10	520	EA	4
4-1/2	443	463	10	488	5	506	5	521	EA	4-1/2
5	444	464	10	489	5	507	5	522	EA	5
5-1/2	445	465	10	490	5	508	5	523	EA	5-1/2
6	446	466	10	491	5	509	5	524	EA	6
6-1/2	—	467	—	492	EA	—	—	—	—	6-1/2
7	—	468	—	493	EA	—	—	—	—	7
7-1/2	—	469	—	494	EA	—	—	—	—	7-1/2
8	—	470	—	495	EA	—	—	—	—	8
8-1/2	—	471	—	—	EA	—	—	—	—	8-1/2
9	—	472	—	496	EA	—	—	—	—	9
10	—	—	—	499	EA	—	—	—	—	10

THE HIGH-ALLOY FASTENING SYSTEM IS DESIGNED AND MANUFACTURED TO BE USED AS A SYSTEM. NO SUBSTITUTIONS OR ALTERATIONS ARE TO BE MADE OF THE BOLT, NUT, WASHER OR FINISH.

C
A
P
S
C
R
E
W
S



IBS, INCORPORATED

Bin Assortments Z06



High Alloy Assortment

FINE THREAD • PLATED ZINC YELLOW

IBS No. 892P • 72 Items - 1,637 Pieces

SAE Hi-Alloy Bolts, SAE Hi-Alloy Flat Washers
SAE Hi-Alloy Finished Nuts, SAE Hi-Alloy Locknuts

- 180,000 psi tensile strength.
- Zinc-plated and dichromate coated.

892P • HI ALLOY ASSORTMENT • 72 Items

1/4-28 Hex Nut	5/16-24 Hex Nut	3/8-24 Hex Nut	7/16-20 Hex Nut	1/2-20 Hex Nut	9/16-18 Hex Nut	5/8-18 Hex Nut	3/4-16 Hex Nut
NT5252	NT5254	NT5256	NT5258	NT5262	NT5264	NT5266	NT5268
1/4 SAE FW	5/16 SAE FW	3/8 SAE FW	7/16 SAE FW	1/2 SAE FW	9/16 SAE FW	5/8 SAE FW	3/4 SAE FW
7400	7401	7402	7403	7404	7405	7406	7407
1/4 Lock Nut	5/16 Lock Nut	3/8 Lock Nut	7/16 Lock Nut	1/2 Lock Nut	9/16 Lock Nut	5/8 Lock Nut	3/4 Lock Nut
NT9453	NT9455	NT9457	NT9459	NT9463	NT9465	NT9467	NT9469
Open Stock	Open Stock	Open Stock	Open Stock	Open Stock	Open Stock	Open Stock	Open Stock
1/4 x 3/4 Capscrew	5/16 x 3/4 Capscrew	3/8 x 3/4 Capscrew	7/16 x 1 Capscrew	1/2 x 1 Capscrew	9/16 x 1-1/4 Capscrew	5/8 x 1-1/4 Capscrew	3/4 x 1-1/2 Capscrew
326	346	365	386	405	431	451	477
1/4 x 1 Capscrew	5/16 x 1 Capscrew	3/8 x 1 Capscrew	7/16 x 1-1/4 Capscrew	1/2 x 1-1/4 Capscrew	9/16 x 1-1/2 Capscrew	5/8 x 1-1/2 Capscrew	3/4 x 1-3/4 Capscrew
327	347	366	387	406	432	452	478
1/4 x 1-1/4 Capscrew	5/16 x 1-1/4 Capscrew	3/8 x 1-1/4 Capscrew	7/16 x 1-1/2 Capscrew	1/2 x 1-1/2 Capscrew	9/16 x 1-3/4 Capscrew	5/8 x 1-3/4 Capscrew	3/4 x 2 Capscrew
328	348	367	388	407	433	453	479
1/4 x 1-1/2 Capscrew	5/16 x 1-1/2 Capscrew	3/8 x 1-1/2 Capscrew	7/16 x 1-3/4 Capscrew	1/2 x 1-3/4 Capscrew	9/16 x 2 Capscrew	5/8 x 2 Capscrew	3/4 x 2-1/2 Capscrew
329	349	368	389	408	434	454	481
1/4 x 1-3/4 Capscrew	5/16 x 1-3/4 Capscrew	3/8 x 2 Capscrew	7/16 x 2 Capscrew	1/2 x 2 Capscrew	9/16 x 2-1/2 Capscrew	5/8 x 2-1/2 Capscrew	3/4 x 3 Capscrew
330	350	370	390	409	436	456	483
1/4 x 2 Capscrew	5/16 x 2 Capscrew	3/8 x 2-1/2 Capscrew	7/16 x 2-1/2 Capscrew	1/2 x 2-1/2 Capscrew	9/16 x 3 Capscrew	5/8 x 3 Capsscrew	3/4 x 3-1/2 Capscrew
331	351	372	392	411	438	458	485

C
A
P
S
C
R
E
W
S



IBS, INCORPORATED

Bin Assortments Z06



High Alloy Assortment

FINE THREAD • PLATED ZINC YELLOW

IBS No. 893P • 72 Items - 1,637 Pieces

SAE Hi-Alloy Bolts, USS Hi-Alloy Flat Washers

SAE Hi-Alloy Finished Nuts, SAE Hi-Alloy Locknuts

- 180,000 psi tensile strength.
- Zinc-plated and dichromate coated.

893P • HI ALLOY ASSORTMENT • 72 Items

1/4-28 Hex Nut	5/16-24 Hex Nut	3/8-24 Hex Nut	7/16-20 Hex Nut	1/2-20 Hex Nut	9/16-18 Hex Nut	5/8-18 Hex Nut	3/4-16 Hex Nut
NT5252	NT5254	NT5256	NT5258	NT5262	NT5264	NT5266	NT5268
1/4 USS FW	5/16 USS FW	3/8 USS FW	7/16 USS FW	1/2 USS FW	9/16 USS FW	5/8 USS FW	3/4 USS FW
7016	7017	7018	7019	7020	7021	7022	7023
1/4 Lock Nut	5/16 Lock Nut	3/8 Lock Nut	7/16 Lock Nut	1/2 Lock Nut	9/16 Lock Nut	5/8 Lock Nut	3/4 Lock Nut
6400	6401	6402	6403	6404	6405	6406	6407
Open Stock	Open Stock	Open Stock	Open Stock	Open Stock	Open Stock	Open Stock	Open Stock
1/4 x 3/4 Capscrew	5/16 x 3/4 Capscrew	3/8 x 3/4 Capscrew	7/16 x 1 Capscrew	1/2 x 1 Capscrew	9/16 x 1-1/4 Capscrew	5/8 x 1-1/4 Capscrew	3/4 x 1-1/2 Capscrew
326	346	365	386	405	431	451	477
1/4 x 1 Capscrew	5/16 x 1 Capscrew	3/8 x 1 Capscrew	7/16 x 1-1/4 Capscrew	1/2 x 1-1/4 Capscrew	9/16 x 1-1/2 Capscrew	5/8 x 1-1/2 Capscrew	3/4 x 1-3/4 Capscrew
327	347	366	387	406	432	452	478
1/4 x 1-1/4 Capscrew	5/16 x 1-1/4 Capscrew	3/8 x 1-1/4 Capscrew	7/16 x 1-1/2 Capscrew	1/2 x 1-1/2 Capscrew	9/16 x 1-3/4 Capscrew	5/8 x 1-3/4 Capscrew	3/4 x 2 Capscrew
328	348	367	388	407	433	453	479
1/4 x 1-1/2 Capscrew	5/16 x 1-1/2 Capscrew	3/8 x 1-1/2 Capscrew	7/16 x 1-3/4 Capscrew	1/2 x 1-3/4 Capscrew	9/16 x 2 Capscrew	5/8 x 2 Capscrew	3/4 x 2-1/2 Capscrew
329	349	368	389	408	434	454	481
1/4 x 1-3/4 Capscrew	5/16 x 1-3/4 Capscrew	3/8 x 2 Capscrew	7/16 x 2 Capscrew	1/2 x 2 Capscrew	9/16 x 2-1/2 Capscrew	5/8 x 2-1/2 Capscrew	3/4 x 3 Capscrew
330	350	370	390	409	436	456	483
1/4 x 2 Capscrew	5/16 x 2 Capscrew	3/8 x 2-1/2 Capscrew	7/16 x 2-1/2 Capscrew	1/2 x 2-1/2 Capscrew	9/16 x 3 Capscrew	5/8 x 3 Capscrew	3/4 x 3-1/2 Capscrew
331	351	372	392	411	438	458	485

C
A
P
S
C
R
E
W
S



Grade 8 Heat Treated Hex Capscrews

- All Grade 8 Capscrews Are Domestically Made.
- 150,000 PSI Minimum Tensile Strength.

**Chamfered End
For Easy Thread
Engagement.**

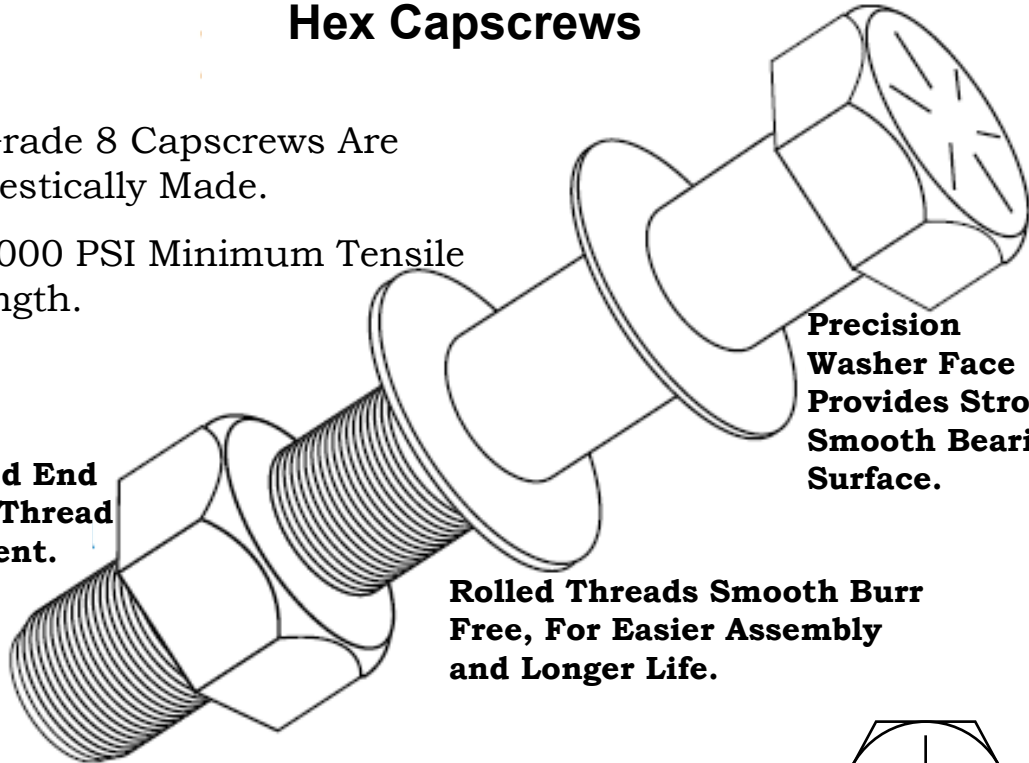

**Precision
Washer Face
Provides Strong
Smooth Bearing
Surface.**

**Rolled Threads Smooth Burr
Free, For Easier Assembly
and Longer Life.**

**E
L
I
M
I
N
A
T
E**

- STRETCHED BOLTS
- STRIPPED THREADS
- BENT OR BROKEN BOLTS
- CRACKED OR DISHED WASHERS
- UNMATCHED COMPONENTS
- VIBRATION, HEAT, OR STRESS FATIGUE

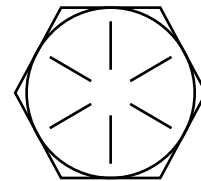

**Grade 8
Bolt Head
Marking**

ALL GRADE 8 BOLTS ARE TRACEABLE TO THEIR ORIGINAL PRODUCTION LOT. SAMPLES OF EACH LOT ARE KEPT ON FILE, WITH ALL DOCUMENTATION REGARDING BATCH DATE, QUALITY CONTROL INSPECTIONS AND TEST REPORTS.



IBS, INCORPORATED

Grade 8 Capscrews Nat'l Coarse A05



USS Grade 8 Capscrews

NATIONAL COARSE — PLAIN

Length	1/4-20 IBS No.	5/16-18 IBS No.	Qty	3/8-16 IBS No.	Qty	7/16-14 IBS No.	Qty	Length
1/2	1301	1325	100	1350	100	—	—	1/2
3/4	1303	1327	100	1352	100	—	—	3/4
1	1304	1329	100	1354	100	1376	50	1
1-1/4	1305	1330	100	1355	100	1377	50	1-1/4
1-1/2	1306	1331	100	1356	100	1378	50	1-1/2
1-3/4	1307	1332	100	1357	100	1379	50	1-3/4
2	1308	1333	100	1358	100	1380	50	2
2-1/4	1309	1334	50	1359	50	1381	25	2-1/4
2-1/2	1310	1335	50	1360	50	1382	25	2-1/2
2-3/4	1311	1336	50	1361	50	1383	25	2-3/4
3	1312	1337	50	1362	50	1384	25	3
3-1/2	1314	1339	50	1364	25	1386	25	3-1/2
4	1316	1341	50	1366	25	1388	25	4
4-1/2	1317	1342	25	1367	25	1389	15	4-1/2
5	1318	1343	25	1368	25	1390	15	5
5-1/2	1319	1344	25	1369	25	—	—	5-1/2
6	1320	1345	25	1370	25	1392	15	6
6-1/2	—	—	—	1371	EA	—	—	6-1/2
7	—	—	—	1372	EA	—	—	7
8	1324	—	EA	1374	EA	—	—	8

**C
A
P
S
C
R
E
W
S**

ALL GRADE 8 BOLTS ARE TRACEABLE TO THEIR ORIGINAL PRODUCTION LOT. SAMPLES OF EACH LOT ARE KEPT ON FILE, WITH ALL DOCUMENTATION REGARDING BATCH DATE, QUALITY CONTROL INSPECTIONS AND TEST REPORTS.



IBS, INCORPORATED

Grade 8 Capscrews Nat'l Coarse A05



USS Grade 8 Capscrews

NATIONAL COARSE — PLAIN



Length	1/2-13 IBS No.	Qty	9/16-12 IBS No.	5/8-11 IBS No.	Qty	3/4-10 IBS No.	Qty	Length
3/4	1397	50	—	—	—	—	—	3/4
1	1398	50	1423	1440	25	1465	20	1
1-1/4	1399	50	1424	1441	25	1466	20	1-1/4
1-1/2	1400	50	1425	1442	25	1467	20	1-1/2
1-3/4	1401	50	1426	1443	25	1468	20	1-3/4
2	1402	50	1427	1444	25	1469	20	2
2-1/4	1403	25	1428	1445	25	1470	20	2-1/4
2-1/2	1404	25	1429	1446	25	1471	20	2-1/2
2-3/4	1405	25	1430	1447	25	1472	20	2-3/4
3	1406	25	1431	1448	25	1473	20	3
3-1/2	1408	25	1433	1450	25	1475	20	3-1/2
4	1410	25	1435	1452	25	1477	20	4
4-1/2	1411	15	1436	1453	15	1478	10	4-1/2
5	1412	15	1437	1454	15	1479	10	5
5-1/2	1413	15	1438	1455	15	1480	10	5-1/2
6	1414	15	1439	1456	15	1481	10	6
6-1/2	1415	EA	—	—	—	1482	EA	6-1/2
7	1416	EA	—	1458	EA	1483	EA	7
8	1418	EA	—	1460	EA	1485	EA	8
9	—	—	—	1462	EA	1487	EA	9
10	—	—	—	1464	EA	1489	EA	10

**C
A
P
S
C
R
E
W
S**

ALL GRADE 8 BOLTS ARE TRACEABLE TO THEIR ORIGINAL PRODUCTION LOT. SAMPLES OF EACH LOT ARE KEPT ON FILE, WITH ALL DOCUMENTATION REGARDING BATCH DATE, QUALITY CONTROL INSPECTIONS AND TEST REPORTS.



IBS, INCORPORATED

Grade 8 Capscrews Nat'l Coarse A05



USS Grade 8 Capscrews

NATIONAL COARSE — PLAIN

Length	7/8-9 IBS No.	Qty	1-8 IBS No.	Qty	1-1/8-7 IBS No.	1-1/4-7 IBS No.	1-1/2-6 IBS No.	Qty	Length
1-1/2	1489A	15	1510A	10	—	—	—	—	1-1/2
1-3/4	1489B	15	—	—	—	—	—	—	1-3/4
2	1490	15	1511	10	—	—	—	—	2
2-1/4	1491	15	1512	10	—	—	—	—	2-1/4
2-1/2	1492	15	1513	10	1532	1548	—	EA	2-1/2
2-3/4	1493	15	1514	10	—	—	—	—	2-3/4
3	1494	10	1515	10	1533	1549	1579	EA	3
3-1/2	1496	10	1517	10	1534	1550	1580	EA	3-1/2
4	1498	10	1519	10	1535	1551	1581	EA	4
4-1/2	1499	5	1520	5	1536	1552	1582	EA	4-1/2
5	1500	5	1521	5	1537	1553	1583	EA	5
5-1/2	1501	5	1522	5	1538	1554	1584	EA	5-1/2
6	1502	5	1523	5	1539	1555	1585	EA	6
6-1/2	—	—	1524	EA	—	1556	—	EA	6-1/2
7	1504	EA	1525	EA	1541	1557	—	EA	7
8	1506	EA	1527	EA	1543	1559	—	EA	8
9	1508	EA	1529	EA	1545	1561	—	EA	9
10	1510	EA	1531	EA	1547	1563	—	EA	10

**C
A
P
S
C
R
E
W
S**

ALL GRADE 8 BOLTS ARE TRACEABLE TO THEIR ORIGINAL PRODUCTION LOT. SAMPLES OF EACH LOT ARE KEPT ON FILE, WITH ALL DOCUMENTATION REGARDING BATCH DATE, QUALITY CONTROL INSPECTIONS AND TEST REPORTS.





Grade 8 Assortment

COARSE THREAD • PLAIN

IBS No. 884P • 72 Items - 3000 Pieces

USS Grade 8 Bolts, SAE HT Flat Washers

USS Grade 8 Finished Nuts, Alloy Lockwashers ZY

- 150,000 psi tensile strength.
- Heat treated.
- Domestically made.
- Plain Finish

884P • GRADE 8 ASSORTMENT • 72 Items

1/4-20 Hex Nut	5/16-18 Hex Nut	3/8-16 Hex Nut	7/16-14 Hex Nut	1/2-13 Hex Nut	9/16-12 Hex Nut	5/8-11 Hex Nut	3/4-10 Hex Nut
4010	4011	4012	4013	4014	4015	4016	4017
1/4 SAE FW	5/16 SAE FW	3/8 SAE FW	7/16 SAE FW	1/2 SAE FW	9/16 SAE FW	5/8 SAE FW	3/4 SAE FW
7000	7001	7002	7003	7004	7005	7006	7007
1/4 Alloy LW	5/16 Alloy LW	3/8 Alloy LW	7/16 Alloy LW	1/2 Alloy LW	9/16 Alloy LW	5/8 Alloy LW	3/4 Alloy LW
7086	7087	7088	7089	7090	7091	7092	7093
Open Stock	Open Stock	Open Stock	Open Stock	Open Stock	Open Stock	Open Stock	Open Stock
1/4 x 3/4 Capscrew	5/16 x 3/4 Capscrew	3/8 x 3/4 Capscrew	7/16 x 1 Capscrew	1/2 x 1 Capscrew	9/16 x 1-1/4 Capscrew	5/8 x 1-1/4 Capscrew	3/4 x 1-1/2 Capscrew
1303	1327	1352	1376	1398	1424	1441	1467
1/4 x 1 Capscrew	5/16 x 1 Capscrew	3/8 x 1 Capscrew	7/16 x 1-1/4 Capscrew	1/2 x 1-1/4 Capscrew	9/16 x 1-1/2 Capscrew	5/8 x 1-1/2 Capscrew	3/4 x 1-3/4 Capscrew
1304	1329	1354	1377	1399	1425	1442	1468
1/4 x 1-1/4 Capscrew	5/16 x 1-1/4 Capscrew	3/8 x 1-1/4 Capscrew	7/16 x 1-1/2 Capscrew	1/2 x 1-1/2 Capscrew	9/16 x 1-3/4 Capscrew	5/8 x 1-3/4 Capscrew	3/4 x 2 Capscrew
1305	1330	1355	1378	1400	1426	1443	1469
1/4 x 1-1/2 Capscrew	5/16 x 1-1/2 Capscrew	3/8 x 1-1/2 Capscrew	7/16 x 1-3/4 Capscrew	1/2 x 1-3/4 Capscrew	9/16 x 2 Capscrew	5/8 x 2 Capscrew	3/4 x 2-1/2 Capscrew
1306	1331	1356	1379	1401	1427	1444	1471
1/4 x 1-3/4 Capscrew	5/16 x 1-3/4 Capscrew	3/8 x 2 Capscrew	7/16 x 2 Capscrew	1/2 x 2 Capscrew	9/16 x 2-1/2 Capscrew	5/8 x 2-1/2 Capscrew	3/4 x 3 Capscrew
1307	1332	1358	1380	1402	1429	1446	1473
1/4 x 2 Capscrew	5/16 x 2 Capscrew	3/8 x 2-1/2 Capscrew	7/16 x 2-1/2 Capscrew	1/2 x 2-1/2 Capscrew	9/16 x 3 Capscrew	5/8 x 3 Capscrew	3/4 x 3-1/2 Capscrew
1308	1333	1360	1382	1404	1431	1448	1475

C
A
P
S
C
R
E
W
S



IBS, INCORPORATED

Bin Assortments Z06

Grade 8 Assortment

COARSE THREAD • PLAIN

IBS No. 885P • 72 Items - 3000 Pieces

USS Grade 8 Bolts, USS HT Flat Washers

USS Grade 8 Finished Nuts. Alloy Lockwasher ZY



- 150,000 psi tensile strength.
- Heat treated.
- Domestically made.
- Plain Finish

885P • GRADE 8 ASSORTMENT • 72 Items

1/4-20 Hex Nut 4010	5/16-18 Hex Nut 4011	3/8-16 Hex Nut 4012	7/16-14 Hex Nut 4013	1/2-13 Hex Nut 4014	9/16-12 Hex Nut 4015	5/8-11 Hex Nut 4016	3/4-10 Hex Nut 4017
1/4 USS FW 7030	5/16 USS FW 7031	3/8 USS FW 7032	7/16 USS FW 7033	1/2 USS FW 7034	9/16 USS FW 7035	5/8 USS FW 7036	3/4 USS FW 7037
1/4 Alloy LW 7086	5/16 Alloy LW 7087	3/8 Alloy LW 7088	7/16 Alloy LW 7089	1/2 Alloy LW 7090	9/16 Alloy LW 7091	5/8 Alloy LW 7092	3/4 Alloy LW 7093
Open Stock	Open Stock	Open Stock	Open Stock	Open Stock	Open Stock	Open Stock	Open Stock
1/4 x 3/4 Capscrew 1303	5/16 x 3/4 Capscrew 1327	3/8 x 3/4 Capscrew 1352	7/16 x 1 Capscrew 1376	1/2 x 1 Capscrew 1398	9/16 x 1-1/4 Capscrew 1424	5/8 x 1-1/4 Capscrew 1441	3/4 x 1-1/2 Capscrew 1467
1/4 x 1 Capscrew 1304	5/16 x 1 Capscrew 1329	3/8 x 1 Capscrew 1354	7/16 x 1-1/4 Capscrew 1377	1/2 x 1-1/4 Capscrew 1399	9/16 x 1-1/2 Capscrew 1425	5/8 x 1-1/2 Capscrew 1442	3/4 x 1-3/4 Capscrew 1468
1/4 x 1-1/4 Capscrew 1305	5/16 x 1-1/4 Capscrew 1330	3/8 x 1-1/4 Capscrew 1355	7/16 x 1-1/2 Capscrew 1378	1/2 x 1-1/2 Capscrew 1400	9/16 x 1-3/4 Capscrew 1426	5/8 x 1-3/4 Capscrew 1443	3/4 x 2 Capscrew 1469
1/4 x 1-1/2 Capscrew 1306	5/16 x 1-1/2 Capscrew 1331	3/8 x 1-1/2 Capscrew 1356	7/16 x 1-3/4 Capscrew 1379	1/2 x 1-3/4 Capscrew 1401	9/16 x 2 Capscrew 1427	5/8 x 2 Capscrew 1444	3/4 x 2-1/2 Capscrew 1471
1/4 x 1-3/4 Capscrew 1307	5/16 x 1-3/4 Capscrew 1332	3/8 x 2 Capscrew 1358	7/16 x 2 Capscrew 1380	1/2 x 2 Capscrew 1402	9/16 x 2-1/2 Capscrew 1429	5/8 x 2-1/2 Capscrew 1446	3/4 x 3 Capscrew 1473
1/4 x 2 Capscrew 1308	5/16 x 2 Capscrew 1333	3/8 x 2-1/2 Capscrew 1360	7/16 x 2-1/2 Capscrew 1382	1/2 x 2-1/2 Capscrew 1404	9/16 x 3 Capscrew 1431	5/8 x 3 Capscrew 1448	3/4 x 3-1/2 Capscrew 1475

C
A
P
S
C
R
E
W
S

IBS, INCORPORATED

Assortments Z08



Grade 8 Assortment

COARSE THREAD • PLAIN

IBS No. 435P • 40 Items - 2085 Pieces

USS Grade 8 Bolts, SAE HT Flat Washers

USS Grade 8 Finished Nuts, Alloy Lockwashers ZY

- 150,000 psi tensile strength.
- Heat treated.
- Domestically made.
- Plain Finish

435P • GRADE 8 ASSORTMENT • 40 Items

1/4-20 Hex Nut 4010	1/4 Alloy LW 7086	1/4 SAE FW 7000	1/4 x 3/4 Capscrew 1303	1/4 x 1 Capscrew 1304	1/4 x 1-1/4 Capscrew 1305	1/4 x 1-1/2 Capscrew 1306	1/4 x 2 Capscrew 1308
5/16-18 Hex Nut 4011	5/16 Alloy LW 7087	5/16 SAE FW 7001	5/16 x 3/4 Capscrew 1327	5/16 x 1 Capscrew 1329	5/16 x 1-1/4 Capscrew 1330	5/16 x 1-1/2 Capscrew 1331	5/16 x 2 Capscrew 1333
3/8-16 Hex Nut 4012	3/8 Alloy LW 7088	3/8 SAE FW 7002	3/8 x 1 Capscrew 1354	3/8 x 1-1/4 Capscrew 1355	3/8 x 1-1/2 Capscrew 1356	3/8 x 2 Capscrew 1358	3/8 x 2-1/2 Capscrew 1360
7/16-14 Hex Nut 4013	5/16 Alloy LW 7089	7/16 SAE FW 7003	7/16 x 1 Capscrew 1376	7/16 x 1-1/4 Capscrew 1377	7/16 x 1-1/2 Capscrew 1378	7/16 x 2 Capscrew 1380	7/16 x 2-1/2 Capscrew 1382
1/2-13 Hex Nut 4014	1/2 Alloy LW 7090	1/2 SAE FW 7004	1/2 x 1 Capscrew 1398	1/2 x 1-1/4 Capscrew 1399	1/2 x 1-1/2 Capscrew 1400	1/2 x 2 Capscrew 1402	1/2 x 2-1/2 Capscrew 1404

C
A
P
S
C
R
E
W
S



IBS, INCORPORATED

Assortments Z08

Grade 8 Assortment

COARSE THREAD • PLAIN

IBS No. 653P • 40 Items - 2085 Pieces

USS Grade 8 Bolts • USS HT Flat Washers

USS Grade 8 Finished Nuts • Alloy Lock Washers ZY



- 150,000 psi tensile strength .
- Heat treated.
- Domestically made.
- Plain Finish

653P • GRADE 8 ASSORTMENT • 40 Items

1/4-20 Hex Nut 4010	1/4 Alloy LW 7086	1/4 USS FW 7030	1/4 x 3/4 Capscrew 1303	1/4 x 1 Capscrew 1304	1/4 x 1-1/4 Capscrew 1305	1/4 x 1-1/2 Capscrew 1306	1/4 x 2 Capscrew 1308
5/16-18 Hex Nut 4011	5/16 Alloy LW 7087	5/16 USS FW 7031	5/16 x 3/4 Capscrew 1327	5/16 x 1 Capscrew 1329	5/16 x 1-1/4 Capscrew 1330	5/16 x 1-1/2 Capscrew 1331	5/16 x 2 Capscrew 1333
3/8-16 Hex Nut 4012	3/8 Alloy LW 7088	3/8 USS FW 7032	3/8 x 1 Capscrew 1354	3/8 x 1-1/4 Capscrew 1355	3/8 x 1-1/2 Capscrew 1356	3/8 x 2 Capscrew 1358	3/8 x 2-1/2 Capscrew 1360
7/16-14 Hex Nut 4013	7/16 Alloy LW 7089	7/16 USS FW 7033	7/16 x 1 Capscrew 1376	7/16 x 1-1/4 Capscrew 1377	7/16 x 1-1/2 Capscrew 1378	7/16 x 2 Capscrew 1380	7/16 x 2-1/2 Capscrew 1382
1/2-13 Hex Nut 4014	1/2 Alloy LW 7090	1/2 USS FW 7034	1/2 x 1 Capscrew 1398	1/2 x 1-1/4 Capscrew 1399	1/2 x 1-1/2 Capscrew 1400	1/2 x 2 Capscrew 1402	1/2 x 2-1/2 Capscrew 1404

C
A
P
S
C
R
E
W
S

IBS, INCORPORATED

Grade 8 C/S - Plated Nat'l Coarse A11



USS Grade 8 Capscrews

NATIONAL COARSE — ZINC YELLOW



Length	1/4-20 IBS No.	5/16-18 IBS No.	Qty	3/8-16 IBS No.	Qty	7/16-14 IBS No.	1/2-13 IBS No.	Qty	Length
1/2	2401	2425	100	2450	100	—	—	—	1/2
3/4	2403	2427	100	2452	100	—	2497	50	3/4
1	2404	2429	100	2454	100	2476	2498	50	1
1-1/4	2405	2430	100	2455	100	2477	2499	50	1-1/4
1-1/2	2406	2431	100	2456	100	2478	2500	50	1-1/2
1-3/4	2407	2432	100	2457	100	2479	2501	50	1-3/4
2	2408	2433	100	2458	100	2480	2502	50	2
2-1/4	2409	2434	50	2459	50	2481	2503	25	2-1/4
2-1/2	2410	2435	50	2460	50	2482	2504	25	2-1/2
2-3/4	2411	2436	50	2461	50	2483	2505	25	2-3/4
3	2412	2437	50	2462	50	2484	2506	25	3
3-1/2	2414	2439	50	2464	25	2486	2508	25	3-1/2
4	2416	2441	50	2466	25	2488	2510	25	4
4-1/2	2417	2442	25	2467	25	2489	2511	15	4-1/2
5	2418	2443	25	2468	25	2490	2512	15	5
5-1/2	2419	2444	25	2469	25	2491	2513	15	5-1/2
6	2420	2445	25	2470	25	2492	2514	15	6
7	—	—	—	—	—	—	2516	10	7
8	—	—	—	—	—	—	2518	10	8

**C
A
P
S
C
R
E
W
S**

ALL GRADE 8 BOLTS ARE TRACEABLE TO THEIR ORIGINAL PRODUCTION LOT. SAMPLES OF EACH LOT ARE KEPT ON FILE, WITH ALL DOCUMENTATION REGARDING BATCH DATE, QUALITY CONTROL INSPECTIONS AND TEST REPORTS.



IBS, INCORPORATED

Grade 8 C/S - Plated Nat'l Coarse A11



USS Grade 8 Capscrews

NATIONAL COARSE — ZINC YELLOW

Length	9/16-12 IBS No.	5/8-11 IBS No.	Qty	3/4-10 IBS No.	Qty	7/8-9 IBS No.	Qty	1-8 IBS No.	Qty	Length
1	2523	2540	25	2565	20	—	—	—	—	1
1-1/4	2524	2541	25	2566	20	—	—	—	—	1-1/4
1-1/2	2525	2542	25	2567	20	2589A	15	2610A	10	1-1/2
1-3/4	2526	2543	25	2568	20	2589B	15	—	—	1-3/4
2	2527	2544	25	2569	20	2590	15	2611	10	2
2-1/4	2528	2545	25	2570	20	2591	15	2612	10	2-1/4
2-1/2	2529	2546	25	2571	20	2592	15	2613	10	2-1/2
2-3/4	2530	2547	25	2572	20	2593	15	2614	10	2-3/4
3	2531	2548	25	2573	20	2594	10	2615	10	3
3-1/2	2533	2550	25	2575	20	2596	10	2617	10	3-1/2
4	2535	2552	25	2577	20	2598	10	2619	10	4
4-1/2	2536	2553	15	2578	10	2599	5	2620	5	4-1/2
5	2537	2554	15	2579	10	2600	5	2621	5	5
5-1/2	2538	2555	15	2580	10	2601	5	2622	5	5-1/2
6	2539	2556	15	2581	10	2602	5	2623	5	6
7	—	2558	5	2583	5	2604	1	2625	1	7
8	—	2560	5	2585	5	2606	1	2627	1	8
9	—	2562	5	2587	1	2608	1	2629	1	9
10	—	2564	1	2589	1	2610	1	2631	1	10

ALL GRADE 8 BOLTS ARE TRACEABLE TO THEIR ORIGINAL PRODUCTION LOT. SAMPLES OF EACH LOT ARE KEPT ON FILE, WITH ALL DOCUMENTATION REGARDING BATCH DATE, QUALITY CONTROL INSPECTIONS AND TEST REPORTS.

CAPSCREWS





Grade 8 Assortment

COARSE THREAD • PLATED ZINC YELLOW

IBS No. 880P • 72 Items - 3000 Pieces

USS Grade 8 Bolts, SAE HT Flat Washers

USS Grade 8 Finished Nuts, Alloy Lock Washers

- 150,000 psi tensile strength.
- Domestically made.
- Heat treated.
- Zinc Yellow Finish

880P • GRADE 8 ASSORTMENT • 72 Items

1/4-20 Hex Nut 4610	5/16-18 Hex Nut 4611	3/8-16 Hex Nut 4612	7/16-14 Hex Nut 4613	1/2-13 Hex Nut 4614	9/16-12 Hex Nut 4615	5/8-11 Hex Nut 4616	3/4-10 Hex Nut 4617
1/4 SAE FW 2660	5/16 SAE FW 2661	3/8 SAE FW 2662	7/16 SAE FW 2663	1/2 SAE FW 2664	9/16 SAE FW 2665	5/8 SAE FW 2666	3/4 SAE FW 2667
1/4 Alloy LW 7086	5/16 Alloy LW 7087	3/8 Alloy LW 7088	7/16 Alloy LW 7089	1/2 Alloy LW 7090	9/16 Alloy LW 7091	5/8 Alloy LW 7092	3/4 Alloy LW 7093
Open Stock	Open Stock	Open Stock	Open Stock	Open Stock	Open Stock	Open Stock	Open Stock
1/4 x 3/4 Capscrew 2403	5/16 x 3/4 Capscrew 2427	3/8 x 3/4 Capscrew 2452	7/16 x 1 Capscrew 2476	1/2 x 1 Capscrew 2498	9/16 x 1-1/4 Capscrew 2524	5/8 x 1-1/4 Capscrew 2541	3/4 x 1-1/2 Capscrew 2567
1/4 x 1 Capscrew 2404	5/16 x 1 Capscrew 2429	3/8 x 1 Capscrew 2454	7/16 x 1-1/4 Capscrew 2477	1/2 x 1-1/4 Capscrew 2499	9/16 x 1-1/2 Capscrew 2525	5/8 x 1-1/2 Capscrew 2542	3/4 x 1-3/4 Capscrew 2568
1/4 x 1-1/4 Capscrew 2405	5/16 x 1-1/4 Capscrew 2430	3/8 x 1-1/4 Capscrew 2455	7/16 x 1-1/2 Capscrew 2478	1/2 x 1-1/2 Capscrew 2500	9/16 x 1-3/4 Capscrew 2526	5/8 x 1-3/4 Capscrew 2543	3/4 x 2 Capscrew 2569
1/4 x 1-1/2 Capscrew 2406	5/16 x 1-1/2 Capscrew 2431	3/8 x 1-1/2 Capscrew 2456	7/16 x 1-3/4 Capscrew 2479	1/2 x 1-3/4 Capscrew 2501	9/16 x 2 Capscrew 2527	5/8 x 2 Capscrew 2544	3/4 x 2-1/2 Capscrew 2571
1/4 x 1-3/4 Capscrew 2407	5/16 x 1-3/4 Capscrew 2432	3/8 x 2 Capscrew 2458	7/16 x 2 Capscrew 2480	1/2 x 2 Capscrew 2502	9/16 x 2-1/2 Capscrew 2529	5/8 x 2-1/2 Capscrew 2546	3/4 x 3 Capscrew 2573
1/4 x 2 Capscrew 2408	5/16 x 2 Capscrew 2433	3/8 x 2-1/2 Capscrew 2460	7/16 x 2-1/2 Capscrew 2482	1/2 x 2-1/2 Capscrew 2504	9/16 x 3 Capscrew 2531	5/8 x 3 Capscrew 2548	3/4 x 3-1/2 Capscrew 2575

C
A
P
S
C
R
E
W
S



IBS, INCORPORATED

Bin Assortments Z06

Grade 8 Assortment

COARSE THREAD • PLATED ZINC YELLOW

IBS No. 881P • 72 Items - 3000 Pieces

USS Grade 8 Bolts, USS HT Flat Washers

USS Grade 8 Finished Nuts, Alloy Lock Washers



- 150,000 psi tensile strength.
- Domestically made.
- Heat treated.
- Zinc Yellow Finish

881P • GRADE 8 ASSORTMENT • 72 Items

1/4-20 Hex Nut	5/16-18 Hex Nut	3/8-16 Hex Nut	7/16-14 Hex Nut	1/2-13 Hex Nut	9/16-12 Hex Nut	5/8-11 Hex Nut	3/4-10 Hex Nut
4610	4611	4612	4613	4614	4615	4616	4617
1/4 USS FW	5/16 USS FW	3/8 USS FW	7/16 USS FW	1/2 USS FW	9/16 USS FW	5/8 USS FW	3/4 USS FW
2770	2771	2772	2773	2774	2775	2776	2777
1/4 Alloy LW	5/16 Alloy LW	3/8 Alloy LW	7/16 Alloy LW	1/2 Alloy LW	9/16 Alloy LW	5/8 Alloy LW	3/4 Alloy LW
7086	7087	7088	7089	7090	7091	7092	7093
Open Stock	Open Stock	Open Stock	Open Stock	Open Stock	Open Stock	Open Stock	Open Stock
1/4 x 3/4 Capscrew	5/16 x 3/4 Capscrew	3/8 x 3/4 Capscrew	7/16 x 1 Capscrew	1/2 x 1 Capscrew	9/16 x 1-1/4 Capscrew	5/8 x 1-1/4 Capscrew	3/4 x 1-1/2 Capscrew
2403	2427	2452	2476	2498	2524	2541	2567
1/4 x 1 Capscrew	5/16 x 1 Capscrew	3/8 x 1 Capscrew	7/16 x 1-1/4 Capscrew	1/2 x 1-1/4 Capscrew	9/16 x 1-1/2 Capscrew	5/8 x 1-1/2 Capscrew	3/4 x 1-3/4 Capscrew
2404	2429	2454	2477	2499	2525	2542	2568
1/4 x 1-1/4 Capscrew	5/16 x 1-1/4 Capscrew	3/8 x 1-1/4 Capscrew	7/16 x 1-1/2 Capscrew	1/2 x 1-1/2 Capscrew	9/16 x 1-3/4 Capscrew	5/8 x 1-3/4 Capscrew	3/4 x 2 Capscrew
2405	2430	2455	2478	2500	2526	2543	2569
1/4 x 1-1/2 Capscrew	5/16 x 1-1/2 Capscrew	3/8 x 1-1/2 Capscrew	7/16 x 1-3/4 Capscrew	1/2 x 1-3/4 Capscrew	9/16 x 2 Capscrew	5/8 x 2 Capscrew	3/4 x 2-1/2 Capscrew
2406	2431	2456	2479	2501	2527	2544	2571
1/4 x 1-3/4 Capscrew	5/16 x 1-3/4 Capscrew	3/8 x 2 Capscrew	7/16 x 2 Capscrew	1/2 x 2 Capscrew	9/16 x 2-1/2 Capscrew	5/8 x 2-1/2 Capscrew	3/4 x 3 Capscrew
2407	2432	2458	2480	2502	2529	2546	2573
1/4 x 2 Capscrew	5/16 x 2 Capscrew	3/8 x 2-1/2 Capscrew	7/16 x 2-1/2 Capscrew	1/2 x 2-1/2 Capscrew	9/16 x 3 Capscrew	5/8 x 3 Capscrew	3/4 x 3-1/2 Capscrew
2408	2433	2460	2482	2504	2531	2548	2575

C
A
P
S
C
R
E
W
S

IBS, INCORPORATED

Assortments Z08



Grade 8 Assortment

COARSE THREAD - PLATED ZINC YELLOW

IBS No. 438P • 40 Items - 1985 Pieces

USS Grade 8 Bolts • SAE HT Flat Washers

USS Grade 8 Finished Nuts • Alloy Lockwashers

- 150,000 psi tensile strength.
- Heat treated.
- Domestically made.
- Plated Finish

438P • GRADE 8 ASSORTMENT • 40 Items

1/4-20 Hex Nut	1/4 Alloy LW	1/4 SAE FW	1/4 x 3/4 Capscrew	1/4 x 1 Capscrew	1/4 x 1-1/4 Capscrew	1/4 x 1-1/2 Capscrew	1/4 x 2 Capscrew
4610	7086	2660	2403	2404	2405	2406	2408
5/16-18 Hex Nut	5/16 Alloy LW	5/16 SAE FW	5/16 x 3/4 Capscrew	5/16 x 1 Capscrew	5/16 x 1-1/4 Capscrew	5/16 x 1-1/2 Capscrew	5/16 x 2 Capscrew
4611	7087	2661	2427	2429	2430	2431	2433
3/8-16 Hex Nut	3/8 Alloy LW	3/8 SAE FW	3/8 x 1 Capscrew	3/8 x 1-1/4 Capscrew	3/8 x 1-1/2 Capscrew	3/8 x 2 Capscrew	3/8 x 2-1/2 Capscrew
4612	7088	2662	2454	2455	2456	2458	2460
7/16-14 Hex Nut	5/16 Alloy LW	7/16 SAE FW	7/16 x 1 Capscrew	7/16 x 1-1/4 Capscrew	7/16 x 1-1/2 Capscrew	7/16 x 2 Capscrew	7/16 x 2-1/2 Capscrew
4613	7089	2663	2476	2477	2478	2480	2482
1/2-13 Hex Nut	1/2 Alloy LW	1/2 SAE FW	1/2 x 1 Capscrew	1/2 x 1-1/4 Capscrew	1/2 x 1-1/2 Capscrew	1/2 x 2 Capscrew	1/2 x 2-1/2 Capscrew
4614	7090	2664	2498	2499	2500	2502	2504

C
A
P
S
C
R
E
W
S



IBS, INCORPORATED

Assortments Z08

Grade 8 Assortment

COARSE THREAD - PLATED ZINC YELLOW

IBS No. 655P • 40 Items - 1985 Pieces

USS Grade 8 Bolts, USS HT Flat Washers

USS Grade 8 Finished Nuts, Alloy Lockwashers



- 150,000 psi tensile strength.
- Heat treated.
- Domestically made.
- Plated Finish

655P • GRADE 8 ASSORTMENT • 40 Items

1/4-20 Hex Nut 4610	1/4 Alloy LW 7086	1/4 USS FW 2770	1/4 x 3/4 Capscrew 2403	1/4 x 1 Capscrew 2404	1/4 x 1-1/4 Capscrew 2405	1/4 x 1-1/2 Capscrew 2406	1/4 x 2 Capscrew 2408
5/16-18 Hex Nut 4611	5/16 Alloy LW 7087	5/16 USS FW 2771	5/16 x 3/4 Capscrew 2427	5/16 x 1 Capscrew 2429	5/16 x 1-1/4 Capscrew 2430	5/16 x 1-1/2 Capscrew 2431	5/16 x 2 Capscrew 2433
3/8-16 Hex Nut 4612	3/8 Alloy LW 7088	3/8 USS FW 2772	3/8 x 1 Capscrew 2454	3/8 x 1-1/4 Capscrew 2455	3/8 x 1-1/2 Capscrew 2456	3/8 x 2 Capscrew 2458	3/8 x 2-1/2 Capscrew 2460
7/16-14 Hex Nut 4613	5/16 Alloy LW 7089	7/16 USS FW 2773	7/16 x 1 Capscrew 2476	7/16 x 1-1/4 Capscrew 2477	7/16 x 1-1/2 Capscrew 2478	7/16 x 2 Capscrew 2480	7/16 x 2-1/2 Capscrew 2482
1/2-13 Hex Nut 4614	1/2 Alloy LW 7090	1/2 USS FW 2774	1/2 x 1 Capscrew 2498	1/2 x 1-1/4 Capscrew 2499	1/2 x 1-1/2 Capscrew 2500	1/2 x 2 Capscrew 2502	1/2 x 2-1/2 Capscrew 2504

C
A
P
S
C
R
E
W
S

IBS, INCORPORATED

Grade 8 Capscrews Nat'l Fine A06



SAE Grade 8 Capscrews

NATIONAL FINE - ZINC YELLOW



Length	1/4-28 IBS No.	5/16-24 IBS No.	3/8-24 IBS No.	Qty	7/16-20 IBS No.	1/2-20 IBS No.	Qty	Length
1/2	1594	1615	1636	100	—	—	—	1/2
3/4	1596	1617	1638	100	1659	1678	50	3/4
1	1598	1619	1640	100	1661	1679	50	1
1-1/4	1599	1620	1641	100	1662	1680	50	1-1/4
1-1/2	1600	1621	1642	100	1663	1681	50	1-1/2
1-3/4	1601	1622	1643	100	1664	1682	50	1-3/4
2	1602	1623	1644	100	1665	1683	50	2
2-1/4	—	—	1645	50	1666	1684	25	2-1/4
2-1/2	1604	1625	1646	50	1667	1685	25	2-1/2
2-3/4	1605	1626	1647	50	1668	1686	25	2-3/4
3	1606	1627	1648	50	1669	1687	25	3
3-1/2	1608	1629	1650	50	1671	1689	25	3-1/2
4	1610	1631	1652	25	1673	1691	25	4
4-1/2	1611	1632	1653	25	1674	1692	15	4-1/2
5	1612	1633	1654	25	1675	1693	15	5
5-1/2	1613	1634	1655	25	1676	1694	15	5-1/2
6	1614	1635	1656	25	1677	1695	15	6

Length	9/16-18 IBS No.	5/8-18 IBS No.	Qty	3/4-16 IBS No.	Qty	7/8-14 IBS No.	Qty	1-14 IBS No.	Qty	Length
1	1700	1717	25	—	—	—	—	—	—	1
1-1/4	1701	1718	25	1741	20	—	—	—	—	1-1/4
1-1/2	1702	1719	25	1742	20	—	—	—	—	1-1/2
1-3/4	1703	1720	25	1743	20	—	—	—	—	1-3/4
2	1704	1721	25	1744	20	1761	15	1774	10	2
2-1/4	1705	1722	25	1745	20	1762	15	1775	10	2-1/4
2-1/2	1706	1723	25	1746	20	1763	15	1776	10	2-1/2
2-3/4	1707	1724	25	1747	20	1764	15	1777	10	2-3/4
3	1708	1725	25	1748	20	1765	10	1778	10	3
3-1/2	1710	1727	25	1750	20	1767	10	1780	10	3-1/2
4	1712	1729	25	1752	20	1769	10	1782	10	4
4-1/2	1713	1730	15	1753	10	1770	5	1783	5	4-1/2
5	1714	1731	15	1754	10	1771	5	1784	5	5
5-1/2	1715	1732	15	1755	10	1772	5	1785	5	5-1/2
6	1716	1733	15	1756	10	1773	5	1786	5	6
6-1/2	—	—	—	1757	EA	—	—	—	—	6-1/2
7	—	1735	EA	1758	EA	—	—	—	—	7

**C
A
P
S
C
R
E
W
S**





IBS, INCORPORATED

Bin Assortments Z06

Grade 8 Assortment

FINE THREAD • PLATED ZINC YELLOW

IBS No. 882P • 72 Items - 2700 Pieces

SAE Grade 8 Bolts, SAE HT Flat Washers

SAE Grade 8 Finished Nuts, Alloy Lock Washers

- 150,000 psi tensile strength.
- Domestically made.
- Heat treated.



882P • GRADE 8 ASSORTMENT • 72 Items

1/4-28 Hex Nut 6640	5/16-24 Hex Nut 6641	3/8-24 Hex Nut 6642	7/16-20 Hex Nut 6643	1/2-20 Hex Nut 6644	9/16-18 Hex Nut 6645	5/8-18 Hex Nut 6646	3/4-16 Hex Nut 6647
1/4 SAE FW 2660	5/16 SAE FW 2661	3/8 SAE FW 2662	7/16 SAE FW 2663	1/2 SAE FW 2664	9/16 SAE FW 2665	5/8 SAE FW 2666	3/4 SAE FW 2667
1/4 Alloy LW 7086	5/16 Alloy LW 7087	3/8 Alloy LW 7088	7/16 Alloy LW 7089	1/2 Alloy LW 7090	9/16 Alloy LW 7091	5/8 Alloy LW 7092	3/4 Alloy LW 7093
Open Stock	Open Stock	Open Stock	Open Stock	Open Stock	Open Stock	Open Stock	Open Stock
1/4 x 3/4 Capscrew 1596	5/16 x 3/4 Capscrew 1617	3/8 x 3/4 Capscrew 1638	7/16 x 1 Capscrew 1661	1/2 x 1 Capscrew 1679	9/16 x 1-1/4 Capscrew 1701	5/8 x 1-1/4 Capscrew 1718	3/4 x 1-1/2 Capscrew 1742
1/4 x 1 Capscrew 1598	5/16 x 1 Capscrew 1619	3/8 x 1 Capscrew 1640	7/16 x 1-1/4 Capscrew 1662	1/2 x 1-1/4 Capscrew 1680	9/16 x 1-1/2 Capscrew 1702	5/8 x 1-1/2 Capscrew 1719	3/4 x 1-3/4 Capscrew 1743
1/4 x 1-1/4 Capscrew 1599	5/16 x 1-1/4 Capscrew 1620	3/8 x 1-1/4 Capscrew 1641	7/16 x 1-1/2 Capscrew 1663	1/2 x 1-1/2 Capscrew 1681	9/16 x 1-3/4 Capscrew 1703	5/8 x 1-3/4 Capscrew 1720	3/4 x 2 Capscrew 1744
1/4 x 1-1/2 Capscrew 1600	5/16 x 1-1/2 Capscrew 1621	3/8 x 1-1/2 Capscrew 1642	7/16 x 1-3/4 Capscrew 1664	1/2 x 1-3/4 Capscrew 1682	9/16 x 2 Capscrew 1704	5/8 x 2 Capscrew 1721	3/4 x 2-1/2 Capscrew 1746
1/4 x 1-3/4 Capscrew 1601	5/16 x 1-3/4 Capscrew 1622	3/8 x 2 Capscrew 1644	7/16 x 2 Capscrew 1665	1/2 x 2 Capscrew 1683	9/16 x 2-1/2 Capscrew 1706	5/8 x 2-1/2 Capscrew 1723	3/4 x 3 Capscrew 1748
1/4 x 2 Capscrew 1602	5/16 x 2 Capscrew 1623	3/8 x 2-1/2 Capscrew 1646	7/16 x 2-1/2 Capscrew 1667	1/2 x 2-1/2 Capscrew 1685	9/16 x 3 Capscrew 1708	5/8 x 3 Capscrew 1725	3/4 x 3-1/2 Capscrew 1750

C
A
P
S
C
R
E
W
S



Grade 8 Assortment

FINE THREAD • PLATED ZINC YELLOW

IBS No. 883P • 72 Items - 2700 Pieces

SAE Grade 8 Bolts, USS HT Flat Washers

SAE Grade 8 Finished Nuts, Alloy Lock Washers

- 150,000 psi tensile strength.
- Domestically made.
- Heat treated.

883P • GRADE 8 ASSORTMENT • 72 Items

1/4-28 Hex Nut 6640	5/16-24 Hex Nut 6641	3/8-24 Hex Nut 6642	7/16-20 Hex Nut 6643	1/2-20 Hex Nut 6644	9/16-18 Hex Nut 6645	5/8-18 Hex Nut 6646	3/4-16 Hex Nut 6647
1/4 USS FW 2770	5/16 USS FW 2771	3/8 USS FW 2772	7/16 USS FW 2773	1/2 USS FW 2774	9/16 USS FW 2775	5/8 USS FW 2776	3/4 USS FW 2777
1/4 Alloy LW 7086	5/16 Alloy LW 7087	3/8 Alloy LW 7088	7/16 Alloy LW 7089	1/2 Alloy LW 7090	9/16 Alloy LW 7091	5/8 Alloy LW 7092	3/4 Alloy LW 7093
Open Stock	Open Stock	Open Stock	Open Stock	Open Stock	Open Stock	Open Stock	Open Stock
1/4 x 3/4 Capscrew 1596	5/16 x 3/4 Capscrew 1617	3/8 x 3/4 Capscrew 1638	7/16 x 1 Capscrew 1661	1/2 x 1 Capscrew 1679	9/16 x 1-1/4 Capscrew 1701	5/8 x 1-1/4 Capscrew 1718	3/4 x 1-1/2 Capscrew 1742
1/4 x 1 Capscrew 1598	5/16 x 1 Capscrew 1619	3/8 x 1 Capscrew 1640	7/16 x 1-1/4 Capscrew 1662	1/2 x 1-1/4 Capscrew 1680	9/16 x 1-1/2 Capscrew 1702	5/8 x 1-1/2 Capscrew 1719	3/4 x 1-3/4 Capscrew 1743
1/4 x 1-1/4 Capscrew 1599	5/16 x 1-1/4 Capscrew 1620	3/8 x 1-1/4 Capscrew 1641	7/16 x 1-1/2 Capscrew 1663	1/2 x 1-1/2 Capscrew 1681	9/16 x 1-3/4 Capscrew 1703	5/8 x 1-3/4 Capscrew 1720	3/4 x 2 Capscrew 1744
1/4 x 1-1/2 Capscrew 1600	5/16 x 1-1/2 Capscrew 1621	3/8 x 1-1/2 Capscrew 1642	7/16 x 1-3/4 Capscrew 1664	1/2 x 1-3/4 Capscrew 1682	9/16 x 2 Capscrew 1704	5/8 x 2 Capscrew 1721	3/4 x 2-1/2 Capscrew 1746
1/4 x 1-3/4 Capscrew 1601	5/16 x 1-3/4 Capscrew 1622	3/8 x 2 Capscrew 1644	7/16 x 2 Capscrew 1665	1/2 x 2 Capscrew 1683	9/16 x 2-1/2 Capscrew 1706	5/8 x 2-1/2 Capscrew 1723	3/4 x 3 Capscrew 1748
1/4 x 2 Capscrew 1602	5/16 x 2 Capscrew 1623	3/8 x 2-1/2 Capscrew 1646	7/16 x 2-1/2 Capscrew 1667	1/2 x 2-1/2 Capscrew 1685	9/16 x 3 Capscrew 1708	5/8 x 3 Capscrew 1725	3/4 x 3-1/2 Capscrew 1750

C
A
P
S
C
R
E
W
S



IBS, INCORPORATED

Assortments Z08

Grade 8 Assortment

FINE THREAD - PLATED ZINC YELLOW

IBS No. 439P • 40 Items - 1840 Pieces

SAE Grade 8 Bolts, SAE HT Flat Washers

SAE Grade 8 Finished Nuts, Alloy Lockwashers



- 150,000 psi tensile strength.
- Heat treated.
- Domestically made.
- Plated Finish

439P • GRADE 8 ASSORTMENT • 40 Items

1/4-28 Hex Nut 6640	1/4 Alloy LW 7086	1/4 SAE FW 2660	1/4 x 3/4 Capscrew 1596	1/4 x 1 Capscrew 1598	1/4 x 1-1/4 Capscrew 1599	1/4 x 1-1/2 Capscrew 1600	1/4 x 2 Capscrew 1602
5/16-24 Hex Nut 6641	5/16 Alloy LW 7087	5/16 SAE FW 2661	5/16 x 3/4 Capscrew 1617	5/16 x 1 Capscrew 1619	5/16 x 1-1/4 Capscrew 1620	5/16 x 1-1/2 Capscrew 1621	5/16 x 2 Capscrew 1623
3/8-24 Hex Nut 6642	3/8 Alloy LW 7088	3/8 SAE FW 2662	3/8 x 1 Capscrew 1640	3/8 x 1-1/4 Capscrew 1641	3/8 x 1-1/2 Capscrew 1642	3/8 x 2 Capscrew 1644	3/8 x 2-1/2 Capscrew 1646
7/16-20 Hex Nut 6643	5/16 Alloy LW 7089	7/16 SAE FW 2663	7/16 x 1 Capscrew 1661	7/16 x 1-1/4 Capscrew 1662	7/16 x 1-1/2 Capscrew 1663	7/16 x 2 Capscrew 1665	7/16 x 2-1/2 Capscrew 1667
1/2-20 Hex Nut 6644	1/2 Alloy LW 7090	1/2 SAE FW 2664	1/2 x 1 Capscrew 1679	1/2 x 1-1/4 Capscrew 1680	1/2 x 1-1/2 Capscrew 1681	1/2 x 2 Capscrew 1683	1/2 x 2-1/2 Capscrew 1685

C
A
P
S
C
R
E
W
S

IBS, INCORPORATED

Assortments Z08



Grade 8 Assortment



FINE THREAD - PLATED ZINC YELLOW
IBS No. 656P • 40 Items - 1840 Pieces
SAE Grade 8 Bolts, USS HT Flat Washers
SAE Grade 8 Finished Nuts, Alloy Lock Washers

- 150,000 psi tensile strength.
- Heat treated.
- Domestically made.
- Plated Finish

656P • GRADE 8 ASSORTMENT • 40 Items

1/4-28 Hex Nut 6640	1/4 Alloy LW 7086	1/4 USS FW 2770	1/4 x 3/4 Capscrew 1596	1/4 x 1 Capscrew 1598	1/4 x 1-1/4 Capscrew 1599	1/4 x 1-1/2 Capscrew 1600	1/4 x 2 Capscrew 1602
5/16-24 Hex Nut 6641	5/16 Alloy LW 7087	5/16 USS FW 2771	5/16 x 3/4 Capscrew 1617	5/16 x 1 Capscrew 1619	5/16 x 1-1/4 Capscrew 1620	5/16 x 1-1/2 Capscrew 1621	5/16 x 2 Capscrew 1623
3/8-24 Hex Nut 6642	3/8 Alloy LW 7088	3/8 USS FW 2772	3/8 x 1 Capscrew 1640	3/8 x 1-1/4 Capscrew 1641	3/8 x 1-1/2 Capscrew 1642	3/8 x 2 Capscrew 1644	3/8 x 2-1/2 Capscrew 1646
7/16-20 Hex Nut 6643	5/16 Alloy LW 7089	7/16 USS FW 2773	7/16 x 1 Capscrew 1661	7/16 x 1-1/4 Capscrew 1662	7/16 x 1-1/2 Capscrew 1663	7/16 x 2 Capscrew 1665	7/16 x 2-1/2 Capscrew 1667
1/2-20 Hex Nut 6644	1/2 Alloy LW 7090	1/2 USS FW 2774	1/2 x 1 Capscrew 1679	1/2 x 1-1/4 Capscrew 1680	1/2 x 1-1/2 Capscrew 1681	1/2 x 2 Capscrew 1683	1/2 x 2-1/2 Capscrew 1685

C
A
P
S
C
R
E
W
S



IBS, INCORPORATED
Grade 5 Capscrew General Information

Grade 5 Hex Capscrews
Heat Treated • Zinc Plated

Cold Forged

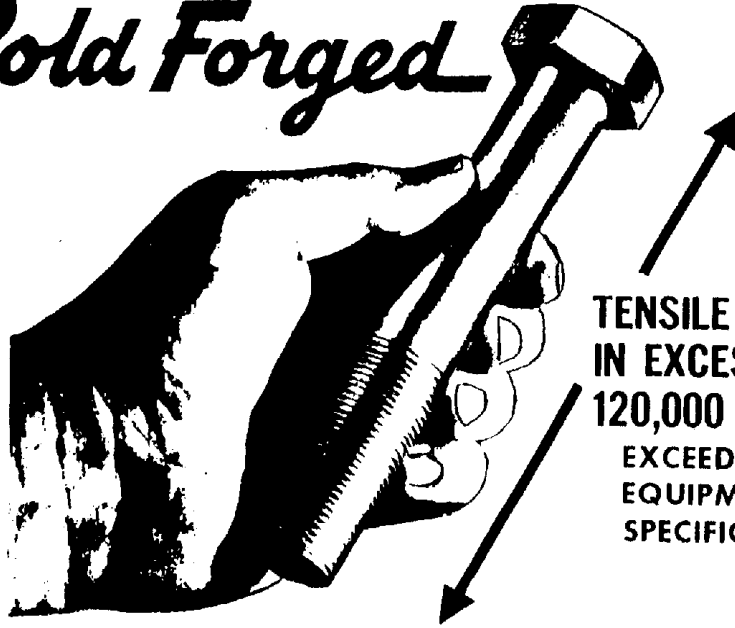

TENSILE STRENGTH
IN EXCESS OF
120,000 PSI
EXCEEDS ORIGINAL
EQUIPMENT
SPECIFICATIONS

- REDUCES DOWN TIME
DUE TO POOR FASTENER ASSEMBLIES
- REDUCES COSTLY WASTED MANHOURS
- REDUCES UNNECESSARY DAMAGE AND WEAR
- INCREASES EFFECTIVENESS
OF EQUIPMENT AND MAINTENANCE PROGRAM

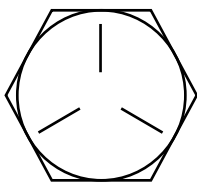

**Grade 5
Bolt Head
Marking**

C
A
P
S
C
R
E
W
S



IBS, INCORPORATED

Grade 5 Capscrews Nat'l Coarse A07



USS Grade 5 Capscrews

NATIONAL COARSE — ZINC



Length	1/4-20 IBS No.	5/16-18 IBS No.	3/8-16 IBS No.	Qty	7/16-14 IBS No.	1/2-13 IBS No.	Qty	Length
1/2	1900	1921	1942	100	—	—	—	1/2
3/4	1902	1923	1944	100	1967	1983	50	3/4
1	1904	1925	1946	100	1968	1984	50	1
1-1/4	1905	1926	1947	100	1969	1985	50	1-1/4
1-1/2	1906	1927	1948	100	1970	1986	50	1-1/2
1-3/4	1907	1928	1949	100	1971	1987	50	1-3/4
2	1908	1929	1950	100	1972	1988	50	2
2-1/4	1909	1930	1951	50	1973	1989	25	2-1/4
2-1/2	1910	1931	1952	50	1974	1990	25	2-1/2
2-3/4	1911	1932	1953	50	1975	1991	25	2-3/4
3	1912	1933	1954	50	1976	1992	25	3
3-1/2	1914	1935	1956	50	1977	1994	25	3-1/2
4	1916	1937	1958	50	1978	1996	25	4
4-1/2	1917	1938	1959	25	1979	1997	15	4-1/2
5	1918	1939	1960	25	1980	1998	15	5
5-1/2	1919	1940	1961	25	1981	1999	15	5-1/2
6	1920	1941	1962	25	1982	2000	15	6

Length	9/16-12 IBS No.	5/8-11 IBS No.	Qty	3/4-10 IBS No.	Qty	7/8-9 IBS No.	1-8 IBS No.	Qty	Length
1	2009	2024	25	2051	20	—	—	—	1
1-1/4	2010	2025	25	2052	20	—	—	—	1-1/4
1-1/2	2011	2026	25	2053	20	2072	—	10	1-1/2
1-3/4	2012	2027	25	2054	20	2073	—	10	1-3/4
2	2013	2028	25	2055	20	2074	2091	10	2
2-1/4	2014	2029	25	2056	20	2075	2092	10	2-1/4
2-1/2	2015	2030	25	2057	20	2076	2093	10	2-1/2
2-3/4	2016	2031	25	2058	20	2077	2094	10	2-3/4
3	2017	2032	25	2059	20	2078	2095	10	3
3-1/2	2018	2034	25	2061	20	2080	2097	10	3-1/2
4	2019	2036	25	2063	20	2082	2099	10	4
4-1/2	2020	2037	15	2064	10	2083	2100	5	4-1/2
5	2021	2038	15	2065	10	2084	2101	5	5
5-1/2	2022	2039	15	2066	10	2085	2102	5	5-1/2
6	2023	2040	15	2067	10	2086	2103	5	6
7	—	2041	—	—	—	—	2105	EA	7
8	—	—	—	—	—	—	2107	EA	8

**C
A
P
S
C
R
E
W
S**





IBS, INCORPORATED

Bin Assortments Z06

Grade 5 Capscrew Assortment

COARSE THREAD — PLATED ZINC

IBS No. 850P • 3340 Pieces - 72 Items

USS Grade 5 Bolts, SAE Flat Washers

USS Grade 5 Finished Nuts, Lockwashers

- 120,000 psi Tensile Strength.
- Heat treated and Zinc plated.



850P • GRADE 5 ASSORTMENT • 72 Items

1/4-20 Hex Nut	5/16-18 Hex Nut	3/8-16 Hex Nut	7/16-14 Hex Nut	1/2-13 Hex Nut	9/16-12 Hex Nut	5/8-11 Hex Nut	3/4-10 Hex Nut
4100	4101	4102	4103	4104	4105	4106	4107
1/4 SAE FW	5/16 SAE FW	3/8 SAE FW	7/16 SAE FW	1/2 SAE FW	9/16 SAE FW	5/8 SAE FW	3/4 SAE FW
7049	7050	7051	7052	7053	7054	7055	7056
1/4 Med LW	5/16 Med LW	3/8 Med LW	7/16 Med LW	1/2 Med LW	9/16 Med LW	5/8 Med LW	3/4 Med LW
7105	7106	7107	7108	7109	7110	7111	7112
Open Stock	Open Stock	Open Stock	Open Stock	Open Stock	Open Stock	Open Stock	Open Stock
1/4 x 3/4 Capscrew	5/16 x 3/4 Capscrew	3/8 x 3/4 Capscrew	7/16 x 1 Capscrew	1/2 x 1 Capscrew	9/16 x 1-1/4 Capscrew	5/8 x 1-1/4 Capscrew	3/4 x 1-1/2 Capscrew
1902	1923	1944	1968	1984	2010	2025	2053
1/4 x 1 Capscrew	5/16 x 1 Capscrew	3/8 x 1 Capscrew	7/16 x 1-1/4 Capscrew	1/2 x 1-1/4 Capscrew	9/16 x 1-1/2 Capscrew	5/8 x 1-1/2 Capscrew	3/4 x 1-3/4 Capscrew
1904	1925	1946	1969	1985	2011	2026	2054
1/4 x 1-1/4 Capscrew	5/16 x 1-1/4 Capscrew	3/8 x 1-1/4 Capscrew	7/16 x 1-1/2 Capscrew	1/2 x 1-1/2 Capscrew	9/16 x 1-3/4 Capscrew	5/8 x 1-3/4 Capscrew	3/4 x 2 Capscrew
1905	1926	1947	1970	1986	2012	2027	2055
1/4 x 1-1/2 Capscrew	5/16 x 1-1/2 Capscrew	3/8 x 1-1/2 Capscrew	7/16 x 1-3/4 Capscrew	1/2 x 1-3/4 Capscrew	9/16 x 2 Capscrew	5/8 x 2 Capscrew	3/4 x 2-1/2 Capscrew
1906	1927	1948	1971	1987	2013	2028	2057
1/4 x 1-3/4 Capscrew	5/16 x 1-3/4 Capscrew	3/8 x 2 Capscrew	7/16 x 2 Capscrew	1/2 x 2 Capscrew	9/16 x 2-1/2 Capscrew	5/8 x 2-1/2 Capscrew	3/4 x 3 Capscrew
1907	1928	1950	1972	1988	2015	2030	2059
1/4 x 2 Capscrew	5/16 x 2 Capscrew	3/8 x 2-1/2 Capscrew	7/16 x 2-1/2 Capscrew	1/2 x 2-1/2 Capscrew	9/16 x 3 Capscrew	5/8 x 3 Capscrew	3/4 x 3-1/2 Capscrew
1908	1929	1952	1974	1990	2017	2032	2061

C
A
P
S
C
R
E
W
S



Grade 5 Capscrew Assortment

COARSE THREAD — PLATED ZINC

IBS No. 851P • 3340 Pieces - 72 Items

USS Grade 5 Bolts, USS Flat Washers

USS Grade 5 Finished Nuts, USS Lockwashers

- 120,000 psi Tensile Strength.
- Heat treated and Zinc plated.

851P • GRADE 5 ASSORTMENT • 72 Items

1/4-20 Hex Nut	5/16-18 Hex Nut	3/8-16 Hex Nut	7/16-14 Hex Nut	1/2-13 Hex Nut	9/16-12 Hex Nut	5/8-11 Hex Nut	3/4-10 Hex Nut
4100	4101	4102	4103	4104	4105	4106	4107
1/4 USS FW	5/16 USS FW	3/8 USS FW	7/16 USS FW	1/2 USS FW	9/16 USS FW	5/8 USS FW	3/4 USS FW
7063	7064	7065	7066	7067	7068	7069	7070
1/4 Med LW	5/16 Med LW	3/8 Med LW	7/16 Med LW	1/2 Med LW	9/16 Med LW	5/8 Med LW	3/4 Med LW
7105	7106	7107	7108	7109	7110	7111	7112
Open Stock	Open Stock	Open Stock	Open Stock	Open Stock	Open Stock	Open Stock	Open Stock
1/4 x 3/4 Capscrew	5/16 x 3/4 Capscrew	3/8 x 3/4 Capscrew	7/16 x 1 Capscrew	1/2 x 1 Capscrew	9/16 x 1-1/4 Capscrew	5/8 x 1-1/4 Capscrew	3/4 x 1-1/2 Capscrew
1902	1923	1944	1968	1984	2010	2025	2053
1/4 x 1 Capscrew	5/16 x 1 Capscrew	3/8 x 1 Capscrew	7/16 x 1-1/4 Capscrew	1/2 x 1-1/4 Capscrew	9/16 x 1-1/2 Capscrew	5/8 x 1-1/2 Capscrew	3/4 x 1-3/4 Capscrew
1904	1925	1946	1969	1985	2011	2026	2054
1/4 x 1-1/4 Capscrew	5/16 x 1-1/4 Capscrew	3/8 x 1-1/4 Capscrew	7/16 x 1-1/2 Capscrew	1/2 x 1-1/2 Capscrew	9/16 x 1-3/4 Capscrew	5/8 x 1-3/4 Capscrew	3/4 x 2 Capscrew
1905	1926	1947	1970	1986	2012	2027	2055
1/4 x 1-1/2 Capscrew	5/16 x 1-1/2 Capscrew	3/8 x 1-1/2 Capscrew	7/16 x 1-3/4 Capscrew	1/2 x 1-3/4 Capscrew	9/16 x 2 Capscrew	5/8 x 2 Capscrew	3/4 x 2-1/2 Capscrew
1906	1927	1948	1971	1987	2013	2028	2057
1/4 x 1-3/4 Capscrew	5/16 x 1-3/4 Capscrew	3/8 x 2 Capscrew	7/16 x 2 Capscrew	1/2 x 2 Capscrew	9/16 x 2-1/2 Capscrew	5/8 x 2-1/2 Capscrew	3/4 x 3 Capscrew
1907	1928	1950	1972	1988	2015	2030	2059
1/4 x 2 Capscrew	5/16 x 2 Capscrew	3/8 x 2-1/2 Capscrew	7/16 x 2-1/2 Capscrew	1/2 x 2-1/2 Capscrew	9/16 x 3 Capscrew	5/8 x 3 Capscrew	3/4 x 3-1/2 Capscrew
1908	1929	1952	1974	1990	2017	2032	2061

C
A
P
S
C
R
E
W
S



IBS, INCORPORATED

Assortments Z08

Grade 5 Capscrew Assortment

COARSE THREAD — PLATED ZINC

IBS No. 651P • 40 Items - 2285 Pieces

USS Grade 5 Bolts, SAE Flat Washers

USS Grade 5 Finished Nuts, Lockwashers



- 120,000 psi Tensile Strength.
- Heat treated and Zinc plated.

651P • GRADE 5 ASSORTMENT • 40 Items

1/4-20 Hex Nut 4100	1/4 Med LW 7105	1/4 SAE FW 7049	1/4 x 3/4 Capscrew 1902	1/4 x 1 Capscrew 1904	1/4 x 1-1/4 Capscrew 1905	1/4 x 1-1/2 Capscrew 1906	1/4 x 2 Capscrew 1908
5/16-18 Hex Nut 4101	5/16 Med LW 7106	5/16 SAE FW 7050	5/16 x 3/4 Capscrew 1923	5/16 x 1 Capscrew 1925	5/16 x 1-1/4 Capscrew 1926	5/16 x 1-1/2 Capscrew 1927	5/16 x 2 Capscrew 1929
3/8-16 Hex Nut 4102	3/8 Med LW 7107	3/8 SAE FW 7051	3/8 x 1 Capscrew 1946	3/8 x 1-1/4 Capscrew 1947	3/8 x 1-1/2 Capscrew 1948	3/8 x 2 Capscrew 1950	3/8 x 2-1/2 Capscrew 1952
7/16-14 Hex Nut 4103	5/16 Med LW 7108	7/16 SAE FW 7052	7/16 x 1 Capscrew 1968	7/16 x 1-1/4 Capscrew 1969	7/16 x 1-1/2 Capscrew 1970	7/16 x 2 Capscrew 1972	7/16 x 2-1/2 Capscrew 1974
1/2-13 Hex Nut 4104	1/2 Med LW 7109	1/2 SAE FW 7053	1/2 x 1 Capscrew 1984	1/2 x 1-1/4 Capscrew 1985	1/2 x 1-1/2 Capscrew 1986	1/2 x 2 Capscrew 1988	1/2 x 2-1/2 Capscrew 1990

C
A
P
S
C
R
E
W
S



Grade 5 Capscrew Assortment

COARSE THREAD • PLATED ZINC

IBS No. 430P • 40 Items - 2285 Pieces

USS Grade 5 Bolts, USS Flat Washers

USS Grade 5 Finished Nuts, Lockwashers



- 120,000 psi Tensile Strength.
- Heat treated and Zinc plated.

430P • GRADE 5 ASSORTMENT • 40 Items

1/4-20 Hex Nut 4100	1/4 Med LW 7105	1/4 USS FW 7063	1/4 x 3/4 Capscrew 1902	1/4 x 1 Capscrew 1904	1/4 x 1-1/4 Capscrew 1905	1/4 x 1-1/2 Capscrew 1906	1/4 x 2 Capscrew 1908
5/16-18 Hex Nut 4101	5/16 Med LW 7106	5/16 USS FW 7064	5/16 x 3/4 Capscrew 1923	5/16 x 1 Capscrew 1925	5/16 x 1-1/4 Capscrew 1926	5/16 x 1-1/2 Capscrew 1927	5/16 x 2 Capscrew 1929
3/8-16 Hex Nut 4102	3/8 Med LW 7107	3/8 USS FW 7065	3/8 x 1 Capscrew 1946	3/8 x 1-1/4 Capscrew 1947	3/8 x 1-1/2 Capscrew 1948	3/8 x 2 Capscrew 1950	3/8 x 2-1/2 Capscrew 1952
7/16-14 Hex Nut 4103	5/16 Med LW 7108	7/16 USS FW 7066	7/16 x 1 Capscrew 1968	7/16 x 1-1/4 Capscrew 1969	7/16 x 1-1/2 Capscrew 1970	7/16 x 2 Capscrew 1972	7/16 x 2-1/2 Capscrew 1974
1/2-13 Hex Nut 4104	1/2 Med LW 7109	1/2 USS FW 7067	1/2 x 1 Capscrew 1984	1/2 x 1-1/4 Capscrew 1985	1/2 x 1-1/2 Capscrew 1986	1/2 x 2 Capscrew 1988	1/2 x 2-1/2 Capscrew 1990

C
A
P
S
C
R
E
W
S



IBS, INCORPORATED

Grade 5 Capscrews Nat'l Fine A08



SAE Grade 5 Capscrews

NATIONAL FINE — ZINC

C
A
P
S
C
R
E
W
S

Length	1/4-28 IBS No.	5/16-24 IBS No.	3/8-24 IBS No.	Qty	7/16-20 IBS No.	1/2-20 IBS No.	Qty	Length
1/2	2200	2221	—	100	—	—	—	1/2
3/4	2202	2223	2243	100	—	2282	50	3/4
1	2204	2225	2245	100	2264	2283	50	1
1-1/4	2205	2226	2246	100	2265	2284	50	1-1/4
1-1/2	2206	2227	2247	100	2266	2285	50	1-1/2
1-3/4	2207	2228	2248	100	2267	2286	50	1-3/4
2	2208	2229	2249	100	2268	2287	50	2
2-1/4	—	2230	2250	50	—	2288	25	2-1/4
2-1/2	2210	2231	2251	50	2270	2289	25	2-1/2
2-3/4	—	—	—	50	—	2290	25	2-3/4
3	2212	2233	2253	50	2272	2291	25	3
3-1/2	2214	2235	2255	50	2274	2293	25	3-1/2
4	2216	2237	2257	50	2276	2295	25	4
4-1/2	—	—	2258	25	2277	2296	15	4-1/2
5	—	—	2259	25	2278	2297	15	5
5-1/2	—	—	2260	25	2279	—	15	5-1/2
6	—	—	2261	25	2280	2299	15	6

Length	9/16-18 IBS No.	5/8-18 IBS No.	Qty	3/4-16 IBS No.	Qty	7/8-14 IBS No.	1-14 IBS No.	Qty	Length
1	2304	2320	25	—	—	—	—	—	1
1-1/4	2305	2321	25	2343	20	—	—	—	1-1/4
1-1/2	2306	2322	25	2344	20	—	—	—	1-1/2
1-3/4	2307	2323	25	2345	20	—	—	—	1-3/4
2	2308	2324	25	2346	20	2367	2380	10	2
2-1/4	2309	2325	25	2347	20	2368	2381	10	2-1/4
2-1/2	2310	2326	25	2348	20	2369	2382	10	2-1/2
2-3/4	2311	2327	25	2349	20	2370	2383	10	2-3/4
3	2312	2328	25	2350	20	2371	2384	10	3
3-1/2	2314	2330	25	2352	20	2373	2386	10	3-1/2
4	2315	2332	25	2354	20	2375	2388	10	4
4-1/2	2316	2333	15	2355	10	2376	2389	5	4-1/2
5	2317	2334	15	2356	10	2377	2390	5	5
5-1/2	2318	2335	15	2357	10	2378	2391	5	5-1/2
6	2319	2336	15	2358	10	2379	2392	5	6





Bin Assortments Z06



Grade 5 Capscrew Assortment

FINE THREAD • PLATED

IBS No. 852P • 2910 Pieces - 72 Items

SAE Grade 5 Bolts, SAE Flat Washers

SAE Grade 5 Finished Nuts, Lockwashers

- 120,000 psi Tensile Strength
- Heat treated and Zinc plated.

852P • GRADE 5 ASSORTMENT • 72 Items

1/4-28 Hex Nut	5/16-24 Hex Nut	3/8-24 Hex Nut	7/16-20 Hex Nut	1/2-20 Hex Nut	9/16-18 Hex Nut	5/8-18 Hex Nut	3/4-16 Hex Nut
4110	4111	4112	4113	4114	4115	4116	4117
1/4 SAE FW	5/16 SAE FW	3/8 SAE FW	7/16 SAE FW	1/2 SAE FW	9/16 SAE FW	5/8 SAE FW	3/4 SAE FW
7049	7050	7051	7052	7053	7054	7055	7056
1/4 Med LW	5/16 Med LW	3/8 Med LW	7/16 Med LW	1/2 Med LW	9/16 Med LW	5/8 Med LW	3/4 Med LW
7105	7106	7107	7108	7109	7110	7111	7112
Open Stock	Open Stock	Open Stock	Open Stock	Open Stock	Open Stock	Open Stock	Open Stock
1/4 x 3/4 Capscrew	5/16 x 3/4 Capscrew	3/8 x 3/4 Capscrew	7/16 x 1 Capscrew	1/2 x 1 Capscrew	9/16 x 1-1/4 Capscrew	5/8 x 1-1/4 Capscrew	3/4 x 1-1/2 Capscrew
2202	2223	2243	2264	2283	2305	2321	2344
1/4 x 1 Capscrew	5/16 x 1 Capscrew	3/8 x 1 Capscrew	7/16 x 1-1/4 Capscrew	1/2 x 1-1/4 Capscrew	9/16 x 1-1/2 Capscrew	5/8 x 1-1/2 Capscrew	3/4 x 1-3/4 Capscrew
2204	2225	2245	2265	2284	2306	2322	2345
1/4 x 1-1/4 Capscrew	5/16 x 1-1/4 Capscrew	3/8 x 1-1/4 Capscrew	7/16 x 1-1/2 Capscrew	1/2 x 1-1/2 Capscrew	9/16 x 1-3/4 Capscrew	5/8 x 1-3/4 Capscrew	3/4 x 2 Capscrew
2205	2226	2246	2266	2285	2307	2323	2346
1/4 x 1-1/2 Capscrew	5/16 x 1-1/2 Capscrew	3/8 x 1-1/2 Capscrew	7/16 x 1-3/4 Capscrew	1/2 x 1-3/4 Capscrew	9/16 x 2 Capscrew	5/8 x 2 Capscrew	3/4 x 2-1/2 Capscrew
2206	2227	2247	2267	2286	2308	2324	2348
1/4 x 1-3/4 Capscrew	5/16 x 1-3/4 Capscrew	3/8 x 2 Capscrew	7/16 x 2 Capscrew	1/2 x 2 Capscrew	9/16 x 2-1/2 Capscrew	5/8 x 2-1/2 Capscrew	3/4 x 3 Capscrew
2207	2228	2249	2268	2287	2310	2326	2350
1/4 x 2 Capscrew	5/16 x 2 Capscrew	3/8 x 2-1/2 Capscrew	7/16 x 2-1/2 Capscrew	1/2 x 2-1/2 Capscrew	9/16 x 3 Capscrew	5/8 x 3 Capscrew	3/4 x 3-1/2 Capscrew
2208	2229	2251	2270	2289	2312	2328	2352

C
A
P
S
C
R
E
W
S



IBS, INCORPORATED

Assortments Z08

Grade 5 Capscrew Assortment

FINE THREAD — PLATED ZINC

IBS No. 853P • 2910 Pieces - 72 Items
SAE Grade 5 Bolts, USS Flat Washers
SAE Grade 5 Finished Nuts, Lockwashers



- 120,000 psi Tensile Strength.
- Heat treated and Zinc plated.

853P • GRADE 5 ASSORTMENT • 72 Items

1/4-28 Hex Nut	5/16-24 Hex Nut	3/8-24 Hex Nut	7/16-20 Hex Nut	1/2-20 Hex Nut	9/16-18 Hex Nut	5/8-18 Hex Nut	3/4-16 Hex Nut
4110	4111	4112	4113	4114	4115	4116	4117
1/4 USS FW	5/16 USS FW	3/8 USS FW	7/16 USS FW	1/2 USS FW	9/16 USS FW	5/8 USS FW	3/4 USS FW
7063	7064	7065	7066	7067	7068	7069	7070
1/4 Med LW	5/16 Med LW	3/8 Med LW	7/16 Med LW	1/2 Med LW	9/16 Med LW	5/8 Med LW	3/4 Med LW
7105	7106	7107	7108	7109	7110	7111	7112
Open Stock	Open Stock	Open Stock	Open Stock	Open Stock	Open Stock	Open Stock	Open Stock
1/4 x 3/4 Capscrew	5/16 x 3/4 Capscrew	3/8 x 3/4 Capscrew	7/16 x 1 Capscrew	1/2 x 1 Capscrew	9/16 x 1-1/4 Capscrew	5/8 x 1-1/4 Capscrew	3/4 x 1-1/2 Capscrew
2202	2223	2243	2264	2283	2305	2321	2344
1/4 x 1 Capscrew	5/16 x 1 Capscrew	3/8 x 1 Capscrew	7/16 x 1-1/4 Capscrew	1/2 x 1-1/4 Capscrew	9/16 x 1-1/2 Capscrew	5/8 x 1-1/2 Capscrew	3/4 x 1-3/4 Capscrew
2204	2225	2245	2265	2284	2306	2322	2345
1/4 x 1-1/4 Capscrew	5/16 x 1-1/4 Capscrew	3/8 x 1-1/4 Capscrew	7/16 x 1-1/2 Capscrew	1/2 x 1-1/2 Capscrew	9/16 x 1-3/4 Capscrew	5/8 x 1-3/4 Capscrew	3/4 x 2 Capscrew
2205	2226	2246	2266	2285	2307	2323	2346
1/4 x 1-1/2 Capscrew	5/16 x 1-1/2 Capscrew	3/8 x 1-1/2 Capscrew	7/16 x 1-3/4 Capscrew	1/2 x 1-3/4 Capscrew	9/16 x 2 Capscrew	5/8 x 2 Capscrew	3/4 x 2-1/2 Capscrew
2206	2227	2247	2267	2286	2308	2324	2348
1/4 x 1-3/4 Capscrew	5/16 x 1-3/4 Capscrew	3/8 x 2 Capscrew	7/16 x 2 Capscrew	1/2 x 2 Capscrew	9/16 x 2-1/2 Capscrew	5/8 x 2-1/2 Capscrew	3/4 x 3 Capscrew
2207	2228	2249	2268	2287	2310	2326	2350
1/4 x 2 Capscrew	5/16 x 2 Capscrew	3/8 x 2-1/2 Capscrew	7/16 x 2-1/2 Capscrew	1/2 x 2-1/2 Capscrew	9/16 x 3 Capscrew	5/8 x 3 Capscrew	3/4 x 3-1/2 Capscrew
2208	2229	2251	2270	2289	2312	2328	2352

C
A
P
S
C
R
E
W
S

IBS, INCORPORATED

Assortments Z08



Grade 5 Capscrew Assortment

FINE THREAD — PLATED ZINC

IBS No. 433P • 40 Items - 1985 Pieces

SAE Grade 5 Bolts, SAE Flat Washers

SAE Grade 5 Finished Nuts, Lockwashers

- 120,000 psi Tensile Strength.
- Heat treated and Zinc plated.

433P • GRADE 5 ASSORTMENT • 40 Items

1/4-28 Hex Nut 4110	1/4 Med LW 7105	1/4 SAE FW 7049	1/4 x 3/4 Capscrew 2202	1/4 x 1 Capscrew 2204	1/4 x 1-1/4 Capscrew 2205	1/4 x 1-1/2 Capscrew 2206	1/4 x 2 Capscrew 2208
5/16-24 Hex Nut 4111	5/16 Med LW 7106	5/16 SAE FW 7050	5/16 x 3/4 Capscrew 2223	5/16 x 1 Capscrew 2225	5/16 x 1-1/4 Capscrew 2226	5/16 x 1-1/2 Capscrew 2227	5/16 x 2 Capscrew 2229
3/8-24 Hex Nut 4112	3/8 Med LW 7107	3/8 SAE FW 7051	3/8 x 1 Capscrew 2245	3/8 x 1-1/4 Capscrew 2246	3/8 x 1-1/2 Capscrew 2247	3/8 x 2 Capscrew 2249	3/8 x 2-1/2 Capscrew 2251
7/16-20 Hex Nut 4113	5/16 Med LW 7108	7/16 SAE FW 7052	7/16 x 1 Capscrew 2264	7/16 x 1-1/4 Capscrew 2265	7/16 x 1-1/2 Capscrew 2266	7/16 x 2 Capscrew 2268	7/16 x 2-1/2 Capscrew 2270
1/2-20 Hex Nut 4114	1/2 Med LW 7109	1/2 SAE FW 7053	1/2 x 1 Capscrew 2283	1/2 x 1-1/4 Capscrew 2284	1/2 x 1-1/2 Capscrew 2285	1/2 x 2 Capscrew 2287	1/2 x 2-1/2 Capscrew 2289

C
A
P
S
C
R
E
W
S



IBS, INCORPORATED

Assortments Z08

Grade 5 Capscrew Assortment

FINE THREAD • PLATED ZINC

IBS No. 652P • 40 Items - 1985 Pieces

SAE Grade 8 Bolts, USS Flat Washers

SAE Grade 8 Finished Nuts, Lockwashers



- 120,000 psi Tensile Strength.
- Heat treated and Zinc plated.

652P • GRADE 5 ASSORTMENT • 40 Items

1/4-28 Hex Nut 4110	1/4 Med LW 7105	1/4 USS FW 7063	1/4 x 3/4 Capscrew 2202	1/4 x 1 Capscrew 2204	1/4 x 1-1/4 Capscrew 2205	1/4 x 1-1/2 Capscrew 2206	1/4 x 2 Capscrew 2208
5/16-24 Hex Nut 4111	5/16 Med LW 7106	5/16 USS FW 7064	5/16 x 3/4 Capscrew 2223	5/16 x 1 Capscrew 2225	5/16 x 1-1/4 Capscrew 2226	5/16 x 1-1/2 Capscrew 2227	5/16 x 2 Capscrew 2229
3/8-24 Hex Nut 4112	3/8 Med LW 7107	3/8 USS FW 7065	3/8 x 1 Capscrew 2245	3/8 x 1-1/4 Capscrew 2246	3/8 x 1-1/2 Capscrew 2247	3/8 x 2 Capscrew 2249	3/8 x 2-1/2 Capscrew 2251
7/16-20 Hex Nut 4113	5/16 Med LW 7108	7/16 USS FW 7066	7/16 x 1 Capscrew 2264	7/16 x 1-1/4 Capscrew 2265	7/16 x 1-1/2 Capscrew 2266	7/16 x 2 Capscrew 2268	7/16 x 2-1/2 Capscrew 2270
1/2-20 Hex Nut 4114	1/2 Med LW 7109	1/2 USS FW 7067	1/2 x 1 Capscrew 2283	1/2 x 1-1/4 Capscrew 2284	1/2 x 1-1/2 Capscrew 2285	1/2 x 2 Capscrew 2287	1/2 x 2-1/2 Capscrew 2289

C
A
P
S
C
R
E
W
S



Grade 8 Flange Bolts

GENERAL INFORMATION

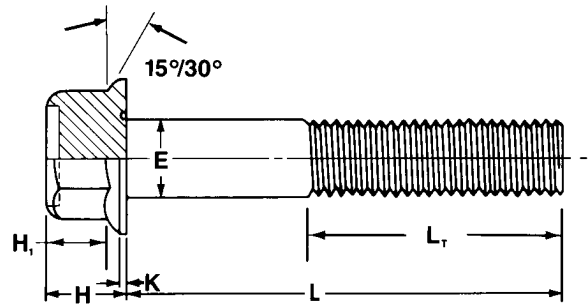
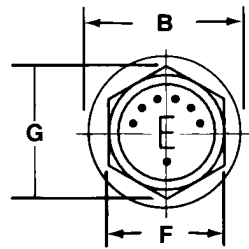
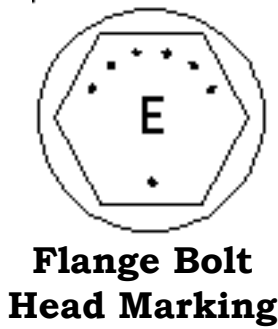

E Size	F WAF*	G WAC*	B Flange Diam.	K Flange Thickness	H Height	H ₁ Hex Height	L _t Thread Length
3/8	9/16	0.65	0.81	0.06	0.39	0.25	1.00
1/2	3/4	0.87	1.07	0.08	0.51	0.34	1.25
5/8	15/16	1.08	1.33	0.10	0.62	0.42	1.50
3/4	1-1/8	1.29	1.59	0.11	0.73	0.51	1.75

WAF - width across flats; WAC = width across corners

Flanged Fastener Advantages

GREATER BEARING AREA

Flange screws have about four times the bearing area of hex screws. This means that clamp loads are distributed over a larger surface, reducing the possibility of the fastener brinelling into the bearing area and thus becoming loose.

Comparison is based on minimum bearing areas as specified by ANSI Standard B18.2 Hex Cap Screws and IFI Standard 111 Hex Flange Screws.

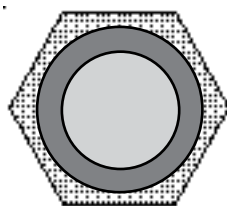

Hex Bolt

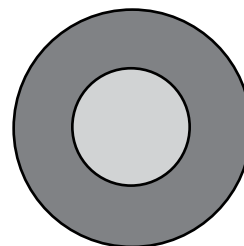

Flange Bolt

Darker area is the bearing surface. The flange bolt has 4 times the bearing area of the hex bolt.

C
A
P
S
C
R
E
W
S



IBS, INCORPORATED

Grade 8 Flange Bolts A10

Better Coverage of Irregular Holes Lower Bearing Stress

Flange screws offer superior coverage and lower bearing stress for irregular holes. For example: with an 11/16" hole elongated 1/8", a 5/8" dia. flange screw offers seven times the bearing area of a 5/8" dia. hex screw, with much lower stress on the bearing area.

Comparisons based on SAE Grade 8 screws tightened to a clamp load of 20,300 lbs., and SAE Grade 5 screws tightened to a clamp load of 14,400 lbs.

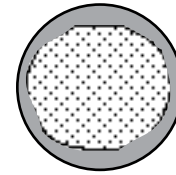
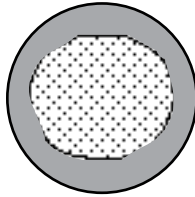

5/8" FLANGED SCREW

1.1882 sq. in. Fastener Diam. Area
- .4572 sq. in. - Hole Area

.7310 sq. in. Bearing Area

5/8" HEX SCREW

.5599 sq. in.
- .4572 sq. in.

.1027 sq. in.

Flanged Screw has 7 times the Bearing Area of the Hex Screw.

Bearing Area

27,800 psi Bearing Area Stress (Grade 8) 198,000 psi
19,700 psi Bearing Area Stress (Grade 5) 140,000 psi

**Bearing Stress on the Flanged Screw is
7 times less than the Hex Screw.**

Elimination of Washers

There are no separate washers to handle and install. That speeds assembly rates. You don't have to worry about washers failing or being forgotten. And, often, you can use shorter length screws.

Weight and Size Reduction

The added rigidity of a flange may allow the use of smaller, lighter nuts.

During final tightening the screw stretches and the nut bearing face tends to dilate, creating above average loads in the nut threads adjacent to the bearing area. If the joint is subject to severe overload, or if too low a grade nut is used, progressive thread shear can occur. Flange nuts, with their added mass at the bearing area, resist this tendency to dilate. This feature can permit the use of smaller across flats nuts with weight reduction savings up to 49%. This is true of both free-running and prevailing torque flange locknuts.

C
A
P
S
C
R
E
W
S



IBS, INCORPORATED

Grade 8 Flange Bolts A10



USS Grade 8 Flange Bolts NATIONAL COARSE



Length	1/4-20 IBS No.	Qty	5/16-18 IBS No.	Qty	3/8-16 IBS No.	Qty	Length
3/4	3110	25	3120	25			
1	3111	25	3121	25	3200	25	1
1-1/4	3112	25	3122	25	3201	25	1-1/4
1-1/2	3113	25	3123	25	3202	25	1-1/2
1-3/4	3114	25	3124	25	3203	25	1-3/4
2	3115	25	3125	25	3204	25	2
2-1/4						25	2-1/4
2-1/2	3116	25	3126	25	3206	25	2-1/2
2-3/4				25	—	—	2-3/4
3	3117	25	3127	25	3130	25	3
3-1/2					3131	10	3-1/2
4					3132	10	4
4-1/2							4-1/2
5							5

Length	1/2-13 IBS No.	Qty	5/8-11 IBS No.	Qty	3/4-10 IBS No.	Qty	Length
1	—	—	—	—	—	—	1
1-1/4	3210	25	3220	25	—	—	1-1/4
1-1/2	3211	25	3221	25	—	—	1-1/2
1-3/4	3212	25	3222	25	—	—	1-3/4
2	3213	25	3223	25	3230	20	2
2-1/4	3214	25	3224	25	3231	20	2-1/4
2-1/2	3215	25	3225	25	3232	20	2-1/2
2-3/4	3140	25	3226	25	—	—	2-3/4
3	3217	25	3227	25	3180	10	3
3-1/2	3141	10	3229	25	3181	5	3-1/2
4	3142	10	3160	10	3182	5	4
4-1/2	3143	10	3161	10	3183	2	4-1/2
5	3144	10	3162	10	3184	2	5

C
A
P
S
C
R
E
W
S



IBS, INCORPORATED

Grade 8 Flange Bolts A10

SAE Grade 8 Flange Bolts

















NATIONAL FINE



Length	1/2-20 IBS No.	Qty	5/8-18 IBS No.	Qty	3/4-16 IBS No.	Qty	Length
1-1/2	3234	25	3291	25	—	—	1-1/2
1-3/4	3236	25	3292	25	—	—	1-3/4
2	3237	25	3293	25	3297	20	2
2-1/4	3237A	25	3170	10	—	—	2-1/4
2-1/2	3238	25	3294	25	3299	20	2-1/2
2-3/4	3150	25	3171	10			2-3/4
3	3151	25	3172	10	3190	10	3
3-1/2	3152	10	3173	10			3-1/2
4	3153	10	3174	10	3191	5	4
4-1/2	3154	10	3175	10			4-1/2
5	3155	10	3176	10	3192	2	5

Grade 8 Flange Bolt Assortment

IBS No. 811R • 15 ITEMS • 405 PIECES

 IBS, Inc. <small>SPECIALTY PRODUCTS FOR MAINTENANCE & REPAIR</small> (800) 678-1906 www.industrialbolt.com				Hex Flange Bolts	
Assortment No. 811R					
3198 1/4-20 FLANGE LOCK NUT GR.G PLN 	3110 1/4-20 X 3/4 GR8 HEX FLANGE BOLT PLN 	3111 1/4-20 X 1 GR8 HEX FLANGE BOLT PLN 	3112 1/4-20 X 1-1/4 GR8 HEX FLANGE BOLT PLN 	3113 1/4-20 X 1-1/2 GR8 HEX FLANGE BOLT PLN 	
3199 5/16-18 FLANGE LOCK NUT GR.G PLN 	3120 5/16-18 X 3/4 GR8 HEX FLANGE BOLT PLN 	3121 5/16-18 X 1 GR8 HEX FLANGE BOLT PLN 	3122 5/16-18 X 1-1/4 GR8 HEX FLANGE BOLT PLN 	3123 5/16-18 X 1-1/2 GR8 HEX FLANGE BOLT PLN 	
4000 3/8-16 FLANGE LOCK NUT GR.G PLN 	3200 3/8-16 X 1 GR8 HEX FLANGE BOLT PLN 	3201 3/8-16 X 1-1/4 GR8 HEX FLANGE BOLT PLN 	3202 3/8-16 X 1-1/2 GR8 HEX FLANGE BOLT PLN 	3204 3/8-16 X 2 GR8 HEX FLANGE BOLT PLN 	

C
A
P
S
C
R
E
W
S

